

# COOLSwitchPro

A/B-Y Switch with Isolation

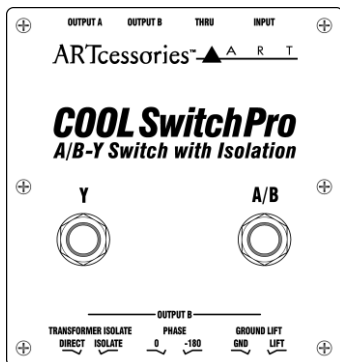

## USER'S MANUAL



## IMPORTANT SAFETY INSTRUCTIONS - READ FIRST



This symbol, wherever it appears, alerts you to the presence of uninsulated dangerous voltages that may be sufficient to constitute a risk of shock.



This symbol, wherever it appears, alerts you to important operating and maintenance instructions in the accompanying literature. Please read the manual.

**Read instructions** Retain these safety and operating instructions for future reference. Heed all warnings printed here and on the equipment. Follow the operating instructions printed in this user guide.

**Do not open** There are no user serviceable parts inside. Refer any service work to qualified technical personnel only.

**Grounding** Only connect the unit to equipment with properly grounded mains power. Do not defeat the grounding and polarization means of the power cord plug of the connected equipment. Do not remove or tamper with the ground connection on the power cord of the connected equipment.

**Environment** Protect from excessive dirt, dust, heat, and vibration when operating and storing. Avoid tobacco ash, drink spillage and smoke, especially that associated with smoke machines.

**Handling** Protect the controls from damage during transit. Use adequate padding if you need to ship the unit. To avoid injury to yourself or damage to the equipment, take care when lifting, moving or carrying the unit.

**Servicing** Refer servicing to qualified technical personnel only.

**Installation** Install the unit in accordance with the instructions printed in the user guide.

## OVERVIEW

The **ART COOLSwitchPro A/B-Y Switch with Isolation** is a handy foot-operated box that lets you switch an instrument signal (guitar, bass, or keyboard) to either of two amplifiers or amp channels, A or B. The "Y" function sends the input signal to both the A and B outputs in parallel.

Switch-selectable features on the B channel add versatility to the basic switching functions. A high quality audio transformer can be switched in to provide isolation between the input and output signals. This helps reduce the danger of shock when the amplifiers are at a different potential. Also, this isolation, along with a ground lift function, helps to eliminate the hum caused by ground loops. A phase reverse function lets you make sure both amps are in phase.

The ART COOLSwitchPro is completely passive with true bypass and is housed in a rugged, stable case with industrial-grade footswitches spaced for easy operation. It will provide many years of reliable service, whether on stage or in the studio.

## Features

- Sends your signal to either of two amps or both with foot control
- Switchable transformer isolation helps prevent shocks and remove hum
- Switchable phase invert helps make sure both amps are properly in phase
- Switchable ground lift helps remove another potential source of hum
- Always connected "thru" jack for use with a tuner or other piece of gear

- Can be used in reverse to select between two instruments connected to one amp
- Passive operation requires no power and provides true bypass
- Rugged all aluminum case sits flat and optimum footswitch spacing allows easy operation
- Perfect for stage or studio use

## **CONNECTIONS**

All connections are made through 1/4-inch TS (mono) jacks whose function is labeled on the top of the unit. Use shielded cables with 1/4-inch TS (two conductor) plugs to connect to these jacks.

### **INPUT**

Plug your instrument (guitar, bass, or keyboard) or other signal source into this jack.

### **THRU**

This jack provides a direct hard-wired connection to the input jack which is not affected by any switch function. Use it to connect to an electronic tuner or to provide an extension to your input cable.

### **OUTPUT A**

Use this jack to connect to your main amplifier or channel.

### **OUTPUT B**

Use this jack to connect to your secondary amplifier or channel. The functions controlled by the rocker switches on the front panel are applied to this output.

## OPERATION

### PUSHBUTTON SWITCHES (top)

#### Y

Pushing this footswitch alternates between connecting the **INPUT** jack to both the **OUTPUT A** and the **OUTPUT B** jacks (the **Y** function) or to just one of the jacks (which one is selected by the **A/B** switch).

#### A/B

Pushing this footswitch alternately connects the **INPUT** jack to either the **OUTPUT A** or the **OUTPUT B** jack., assuming the **Y** function is disabled.

### ROCKER SWITCHES (front)

The functions controlled by these switches operate on the **OUTPUT B** jack.

## TRANSFORMER ISOLATE

This switch allows you to insert the audio isolation transformer between the **INPUT** and **OUTPUT B** jacks. In the **DIRECT** position, the transformer is bypassed. In the **ISOLATE** position, the transformer is inserted.

## PHASE

This switch allows you to invert the phase of the signal to the **OUTPUT B** jack. This function is only available when the **TRANSFORMER ISOLATE** switch is in the **ISOLATE** position. When the **PHASE** switch is in the **0** position, the phase is not affected. In the **-180** position, the phase is inverted.

## GROUND LIFT

This switch allows you to break the **OUTPUT B** ground connection from directly connecting to the other ground connections. In the **GND** position, **OUTPUT B's** ground is connected. In the **LIFT** position, the direct connection is broken and there is only an AC signal path to ground.

## APPLICATION

The COOLSwitchPro is a simple product. You might not think there would be much to say about how to use it, but it turns out there's quite a bit we'd like to say.

First, let's talk about safety. The COOLSwitchPro doesn't plug into an AC outlet, but because one of its main applications is to connect to two power amplifiers that **do** plug into AC, the possibility exists for dangerous voltages to exist, especially if the amps are not properly grounded. Make sure your amps are equipped with the proper plugs incorporating safety grounds and that you're using equipment approved by recognized safety agencies (UL, CSA, etc.). Plugging all your equipment into the same circuit (e.g. by using a single power strip) can help reduce the danger of shocks. Don't use an amp with a two-pronged plug or defeat the ground function of a three-pronged plug by using a cheater adapter unless you **really** know what you're doing, are feeling lucky, or don't mind going out in a blaze of glory. You've been warned!

Now let's talk about actually using this thing. Before making any connections, make sure your amps are unplugged, with their power switches off and their volume controls turned all the way down. Now connect your guitar or other instrument to the **INPUT** jack of the COOLSwitchPro using a cable with 1/4-inch phone plugs on each end (hereafter referred to as a "guitar cable"). Use guitar cables to connect the COOLSwitchPro's **OUTPUT A** jack to your main amplifier and **OUTPUT B** jack to your alternate amp. All rocker-switch functions operate on the signal going to the **OUTPUT B** jack. For now, make sure all rocker switches are switched to the left and in their normal or inactive position (**DIRECT**, **0**, and **GND**).

Next, assuming you paid attention to the safety warnings above, connect your amplifiers to AC power.



No smoke or sparks? Good. Now turn on the amps and turn up the volume controls slightly. While strumming your guitar or otherwise creating an input signal, verify that you get sound from both amps by toggling the **A/B** footswitch. Toggle the **Y** footswitch and verify that the sound comes from both amps or just one. With sound from both amps, now's a good time to listen for hum. If you hear any, try switching the **GROUND LIFT** switch in the front to the **LIFT** position. If you still hear hum, try switching the **TRANSFORMER ISOLATE** switch to the **ISOLATE** position. For reducing hum, always try the ground lift first, then use the transformer for isolation only if necessary, to minimize the effect the COOLSwitchPro has on your signal.

Next, let's check that your amps are in phase, or, in other words, that the speakers move in the same direction when playing the same signal. As you might guess, the **PHASE** switch is what we'll use to fix phase problems. However, note that this switch only works when the transformer is switched in (**TRANSFORMER ISOLATE** switch in the **ISOLATE** position). Set up your amps side by side and set them for equal volume. Make sure the **Y** footswitch is toggled so that sound comes from both amps. While strumming your guitar (lower frequencies or bass notes work best), try switching the **PHASE** switch back and forth. One position should yield sound that is fuller, more centered and with more defined bass, a sign that the amps are in phase, The other position should sound weaker and more hollow and unfocused, indicating the amps are out of phase. Use the setting you prefer (you may like hollow, weak sound).

That's all you really need to know to use your COOLSwitchPro. However, here's a few more things to think about.

## Other Uses

Connect your electronic tuner to the **THRU** jack for tuning on-the-fly. Or, if you prefer, connect your tuner to the **OUTPUT B** jack (instead of using this jack for a second amp) to provide silent tuning. The **A/B** footswitch will act as a mute switch, sending your guitar signal to the tuner instead of to your amp. Push the footswitch again and you're back in business.

The COOLSwitchPro can be used to switch between two amp channels as easily as it can switch between two separate amps. Or you can turn things around and switch two different guitars (or guitar and keyboard or two different keyboards or .... you get the idea) between one amp or amp channel. Since the COOLSwitchPro is completely passive, the normal rules of keeping your inputs and outputs straight don't apply.

The COOLSwitchPro would normally be the last pedal in your signal chain before the amps, but that doesn't mean you can't change things up a bit and put some pedals **after** it. For example, you might have some effects that "go" with one amp but not the other. Play around, break the "rules". You won't hurt the COOLSwitchPro!

## Passive vs. Active

We've mentioned that the COOLSwitchPro is a passive device. This has certain benefits, like being able to disregard whether a jack is an input or an output, as we talked about above. It also means that no power is required.

However, there can be downsides. Some guitar pickups are relatively high impedance signal sources. A passive device can "load" them down. This lowers the signal level and can affect the frequency response. You may notice a slight loss of higher

frequencies with some guitar pickups when using the COOLSwitchPro, especially with the phase reversed.

There are several things you can do to minimize these effects. Try adjusting your amp's volume and tone controls to compensate. Keep your guitar's level controls all the way up so that the control's impedance doesn't add to the pickup impedance. Try using a preamp, or any active effect pedal, between your guitar and the COOLSwitchPro. Finally, if possible, try using a different pickup.

## BLOCK DIAGRAM

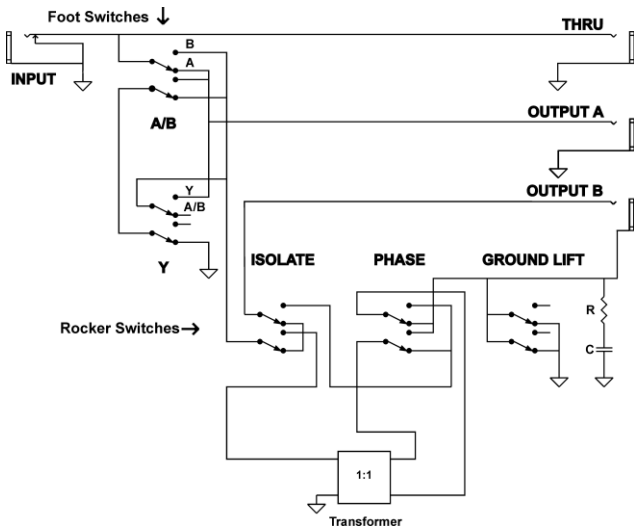

## WARRANTY INFORMATION

### Limited Warranty (USA only)

Applied Research and Technology will provide warranty and service for this unit in accordance with the following warrants:

Applied Research and Technology, (ART) warrants to the original purchaser that this product and the components thereof will be free from defects in workmanship and materials for a period of **three** years from the date of purchase. Applied Research and Technology will, without charge, repair or replace, at its option, defective product or component parts upon prepaid delivery to the factory service department or authorized service center, accompanied by proof of purchase date in the form of a valid sales receipt.

### Exclusions

This warranty does not apply in the event of misuse or abuse of the product or as a result of unauthorized alterations or repairs. This warranty is void if the serial number is altered, defaced, or removed.

ART reserves the right to make changes in design or make additions to or improvements upon this product without any obligation to install the same on products previously manufactured.

ART shall not be liable for any consequential damages, including without limitation damages resulting from loss of use. Some states do not allow limitations of incidental or consequential damages, so the above limitation or exclusion may not apply to you. This warranty gives you specific rights

and you may have other rights, which vary, from state to state. The warranty terms listed above are only valid within the United States of America.

For units purchased outside the United States, an authorized distributor of Applied Research and Technology will provide service. For information on warranty and service policies outside of the U.S., please contact your local distributor.

Please fill in the following information for your reference:

Date of purchase: \_\_\_\_\_

Purchased from: \_\_\_\_\_

Serial Number: \_\_\_\_\_

## SERVICE

The following information is provided in the unlikely event that your unit requires service.

1. Be sure that the unit is the cause of the problem. Check to make sure that the unit has power supplied, that all cables are connected correctly, and that the cables themselves are in working condition. You may want to consult with your dealer for assistance in troubleshooting or testing your particular configuration.
2. If you believe that the ART unit is at fault, go to [www.artproaudio.com](http://www.artproaudio.com). Select "Support", then "Return Authorization Request" to request a return authorization number.
3. If you are returning the unit for service, pack the unit in its original carton or a reasonable substitute. The original packaging may not be suitable as a shipping carton, so consider putting the packaged unit in another box for shipping. Print the RA number clearly on the outside of the shipping box. Print your return shipping address on the outside of the box.
4. Include with your unit: a note with the RA number and your contact information, including a return shipping address (we cannot ship to a P.O. box) and a daytime phone number, and a description of the problem, preferably attached to the top of the unit. Also include a copy of your purchase receipt.

## **SPECIFICATIONS**

Connections	1/4-inch TS mono, unbalanced
Transformer Turns Ratio	1:1
Dimensions (HWD)	2.00" x 4.65" x 5.00" 51mm x 118mm x 127mm
Weight	1.0 lb (0.45 kg)



**[www.artproaudio.com](http://www.artproaudio.com)**  
**E-mail: [support@artproaudio.com](mailto:support@artproaudio.com)**

© 2014 Applied Research & Technology

**COOLSwitchPro**  
**CSP-5004-101**  
**V1.1**