

JBL EON 1500 Users Guide



Contents

Welcome	2
Before You Begin	3
<i>Rigging/Suspending</i>	
<i>Stand Mounting</i>	
<i>Hearing Damage</i>	
<i>Outdoor Applications</i>	
Product Features	4
Accessories	5
Cables & Connections	6
<i>Wire Gauges</i>	
<i>Polarity</i>	
<i>Looping Speakers</i>	
Input Panel	7
SonicGuard™	8
System Configurations	9
Suggested Application	10
Troubleshooting Guide	11
Specifications & Warranty	12
Translated Text	13

Part # 981-00051-00



Welcome

Welcome to the family of discerning sound equipment users who have selected JBL Professional speakers. This Owner's Manual contains important information that will help you get the most from your JBL speakers so please take a few moments to read it and be sure to keep it in a safe place for future reference.

Thanks from all of us at JBL Professional.

Model: EON1500 **Serial Number:** _____

Purchased from (dealer): _____

Purchase date: _____

JBL Professional Contact Information



H A Harman International Company

JBL Professional
8500 Balboa Ave.
Northridge, CA 91329

www.jblpro.com



Before You Begin

JBL

PROFESSIONAL

Important information

Before using your EON1500 speaker system please review the following for important information on safety and protection of your investment in quality loudspeakers.

Rigging / suspending EON1500

EON1500 may be permanently installed using wall and ceiling mount brackets available separately from JBL (see Available Accessories) as well as from 3rd party suppliers. Be certain to read and follow all instructions included with the mounting accessories. No other suspension or rigging of EON1500 is supported.

Stand mounting

EON1500 includes a receptacle cup with a thumb screw to facilitate mounting on tripod stands with a 35 mm pole. When using these stands, be sure to observe the following precautions:

- Check the stand specification to be certain it is designed to support the weight of the speaker.
- Observe all safety precautions specified by the stand manufacturer.
- Always verify that the stand is placed on a flat, level, and stable surface.
- Route cables so that performers, crew, and audience will not trip over them and pull the speaker over.
- Be sure to fully extend the legs of tripod type stands.
- Position the stand so that the legs do not present a trip hazard.
- Do not attempt to place more than one speaker on a stand.
- Always be cautious in windy, outdoor conditions. It may be necessary to place additional weight (ie. sandbags) on the base of the stand to improve stability.

Hearing damage, prolonged exposure to excessive SPL

EON1500 loudspeakers are easily capable of generating sound pressure levels (SPL) sufficient to cause permanent hearing damage to performers, production crew and audience members. Caution should be taken to avoid prolonged exposure to SPL in excess of 85 dB.

Exposure to moisture, outdoor applications

While EON1500 loudspeakers will work great for outdoor sound reinforcement they are not "weather-proof" and are not intended for continuous exposure to extremes of humidity, temperature, salt air, or UV rays. Exposure to outdoor environmental conditions may result in premature failure of components as well as degradation to appearance.

Product Features

JBL EON loudspeakers represent a breakthrough in technology and performance that has set a new standard for portable sound loudspeaker systems. The EON1500 joins the EON line and offers those who already own external power amplifiers or powered mixers the performance and appearance for which EON is well-known.

EON1500 15" 2-Way Speaker System

- Liquid cooled titanium-diaphragm compression driver.
- Molded one-piece baffle with integral 90° x 60° constant directivity horn.
- SonicGuard™ circuitry unobtrusively protects the compression driver from overpowering.
- Multi-angle enclosure for flexibility - use EON1500 as a main PA speaker or floor monitor.
- Handsome, all black enclosure is unobtrusive and professional in appearance.
- Enclosure and baffle are molded of tough, durable co-polymer material. EON 1500 will stand up to impact that would cause the joints on a conventional enclosure to separate.
- A heavy-duty, perforated metal grill protects the woofer.
- Ergonomically designed balanced handle and lightweight enclosure for easy and comfortable carrying.
EON1500 weighs a mere 38 lbs. (17.2 kg.)
- Dual 1/4" phone jack inputs.
- Attachment points for wall or ceiling-mounting brackets (brackets available separately).
- Integral 35 mm pole mount receptacle with securing thumb screw.

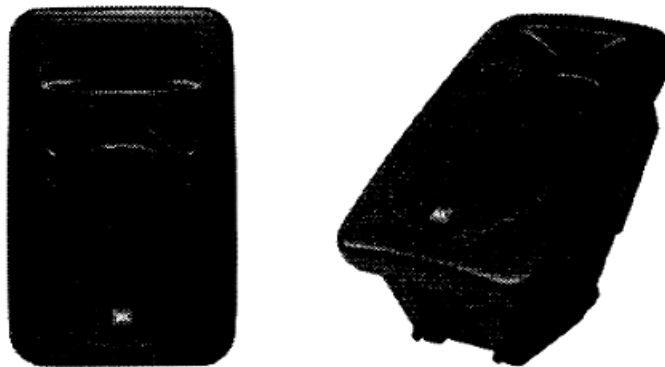

About the EON1500 enclosure

The enclosure and baffle of your EON1500 are made of polypropylene co-polymer. The use of co-polymer allows features such as stand-mounting sockets, hand-holds, ports, and high frequency horns to be molded directly into the cabinet. Not only do you get contemporary appearance, you also get lots of functionality.

Available Accessories



BRK-1 Fixed Angle Wall-Mount Brackets

These brackets bolt directly to inserts that are molded into the rear of the EON1500 enclosure and provide a safe and simple method to mount your speakers to a wall, vertical post, or truss. The bracket supports two tilt angles, 30° from the vertical and 20° from the vertical.



BRK4-15 Adjustable Ceiling and Wall-Mount Brackets

These brackets bolt directly to inserts molded into the rear of the EON1500 enclosure and provide complete flexibility in adjusting the horizontal and vertical angles of the speaker. Mounting to truss, vertical and horizontal surfaces is supported.

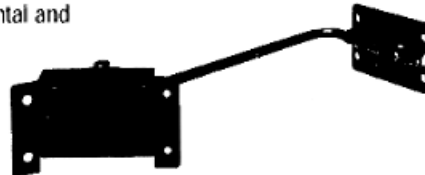

EON15 Bag - Carrying Bag

Protect your EON1500 speakers during transport with this padded, Cordura bag. The bag features an easy-carry shoulder strap and handsome, embroidered JBL logo.



SS2-BK Tripod Stand

Put your EON1500 speakers up where they belong with this rugged, lightweight, aluminum tripod stand. Poly-carbonate clamping joints resist cracking and breaking.

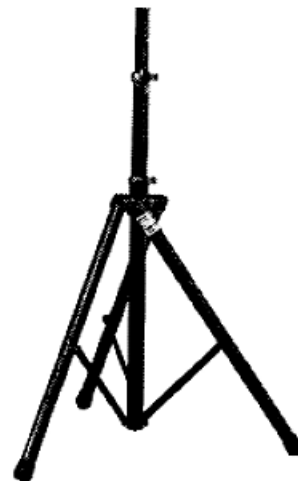

Cable & Connections

The EON1500 features standard 1/4" phone jack inputs with a parallel "loop-through" for connection to additional speakers. For optimum performance it is important to use cables specifically designed for speaker use. Do not use shielded "guitar" signal cables for connection to your EON1500 speakers.

Wire Gauges

Selection of the appropriate wire gauge is important to system operation. A cable that is too light will result in amplifier power being wasted due to the series resistance of the cable. In addition, loss of low-frequency performance may be experienced due to degraded damping factor. The chart below illustrates the appropriate minimum wire gauge for various cable length and speaker impedance combinations.

When using this chart, keep in mind that the two 8 ohm speakers in parallel will equal a 4 ohm load (see "Looping Speakers" below).

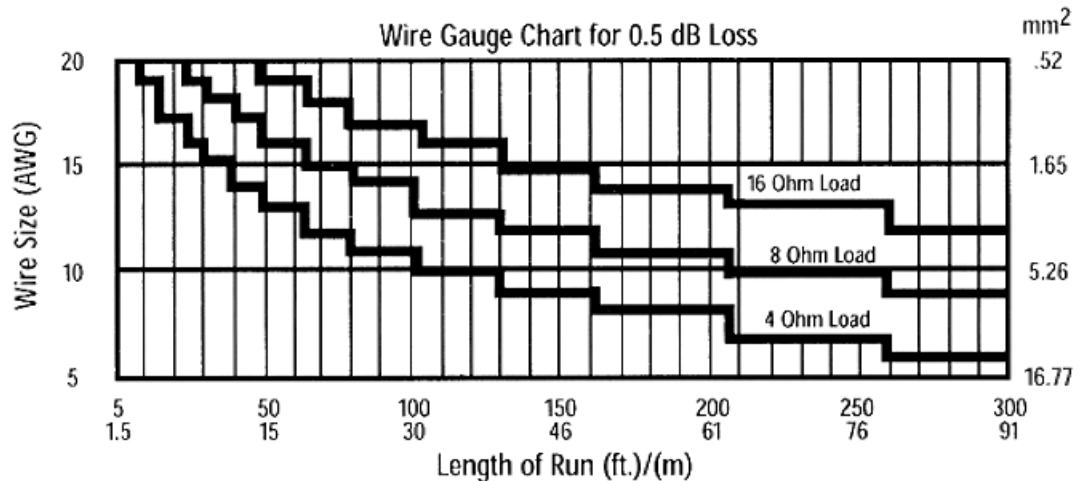

Additional Information

Polarity

A positive voltage applied to the tip of the 1/4" phone plug will produce a forward movement of the speaker cone.

Looping speakers

Running too many speakers from a single amplifier channel may result in damage to the amplifier and/or degraded audio performance. To calculate the combined impedance of multiple identical speakers in parallel:

$$\frac{\text{Impedance of a single speaker}}{\text{Number of speakers connected in parallel}} = \text{Amplifier load}$$

See your power amplifier owner's manual for information on minimum recommended load impedance.

Input Panel

Loop thru capability

The two jacks on the rear panel of the EON1500 are wired in parallel. This means whatever you plug in to either of the two jacks is available to "patch out" of the other jack to another loudspeaker.

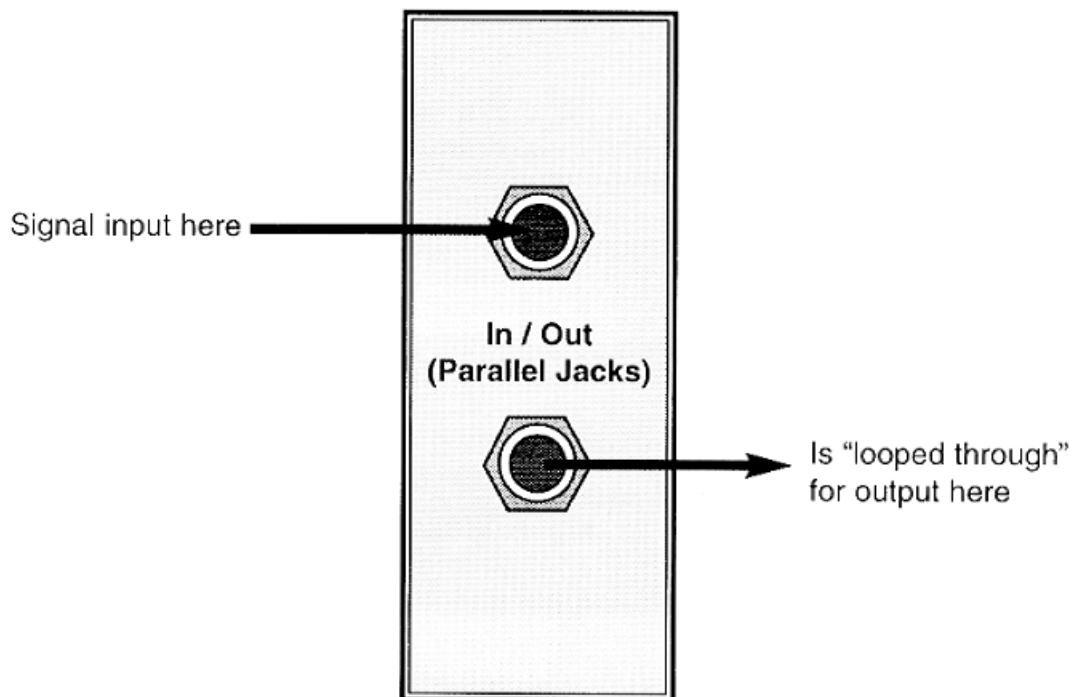

SonicGuard™

EON1500 speakers are equipped with JBL's SonicGuard™ circuitry which protects your high frequency driver against damage from occasional overpowering of the system. SonicGuard™ gently compresses the signal in a virtually inaudible manner by diverting the excess power away from the compression driver.

- SonicGuard™ protection does not stress your amplifier during compression. Nor does it create additional amplifier distortion or overly restrict maximum SPL.
- SonicGuard™ does not interrupt your performance.
- SonicGuard™ provides protection against peak and average overpowering while passing transients that contribute to the character of the music.

Note: SonicGuard™ circuitry incorporates light bulbs which illuminate when the circuitry activates. The light may be visible outside the speaker. This simply means that SonicGuard™ is protecting your drivers. Should the lights illuminate for more than a brief period, you should decrease the volume.

Should I Fuse My Speakers?

SonicGuard™ provides speaker protection that is far superior to fuses. JBL does not recommend fusing components. A fuse may blow with a signal that would not damage the speaker or pass a signal that can damage the speaker. To protect your system best, JBL advises using adequate, clean amplifier power and minimizing amplifier clipping. Another option is to add a limiter to your system to electronically limit damaging transient information.

System Configurations

JBL

PROFESSIONAL

Unpowered Mixer System

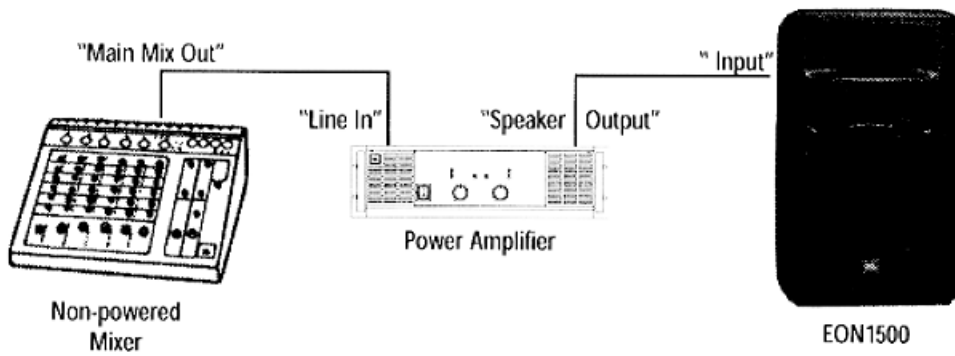

Powered Mixer System

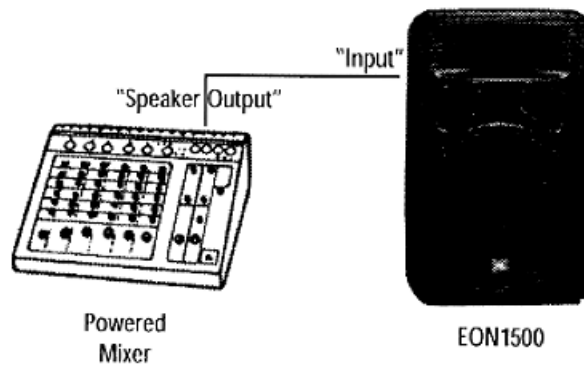

Application Suggestion

EON1500 speakers will work great in combination with EON Powered-Series speakers.

- EON1500 speakers are used for the main, front-of-house speakers
- EON PowerSub speakers are used to provide additional low-frequency power
- EON Power 10 speakers are used as floor monitors

EON1500 with EON Powered Series

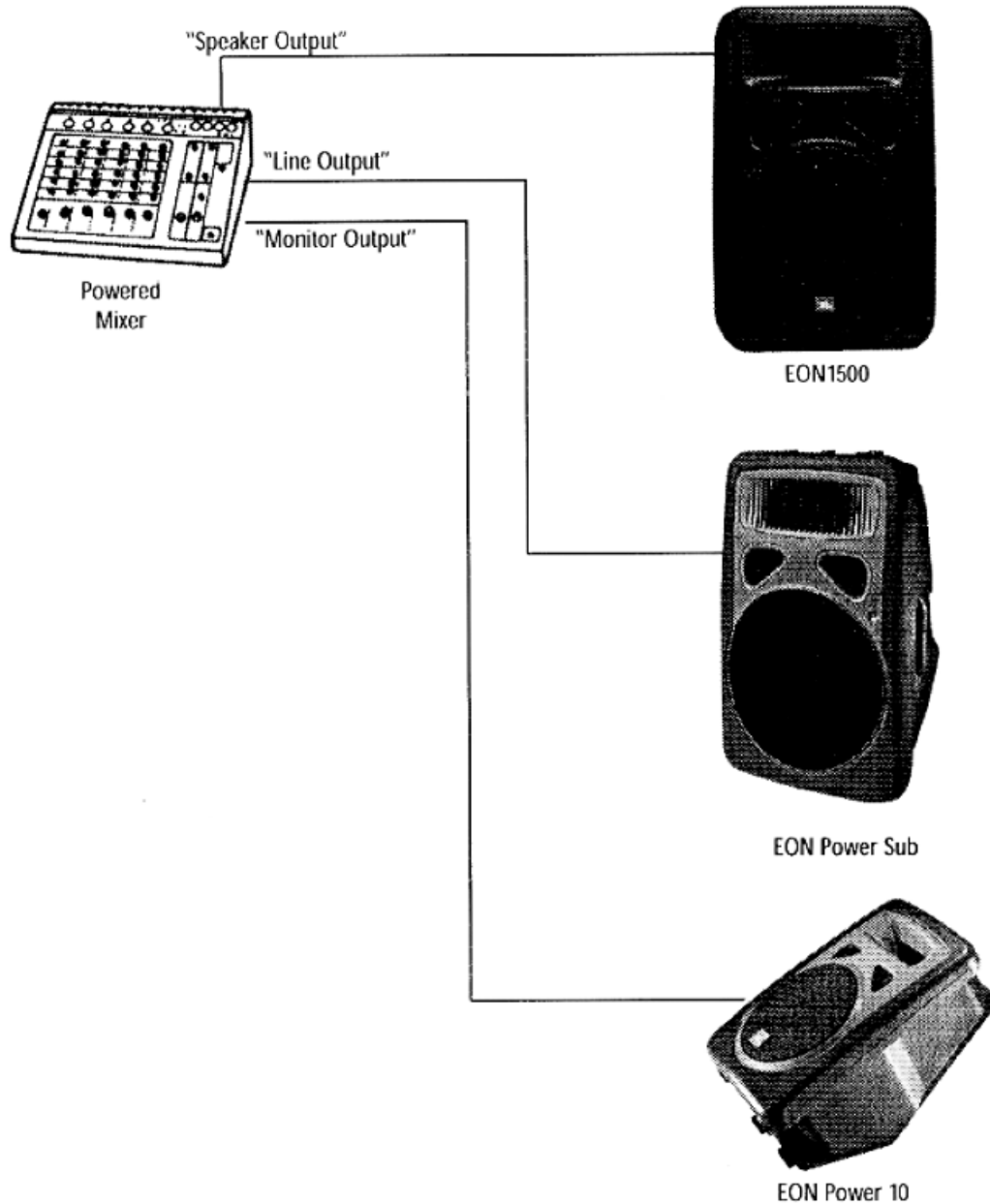

One certain method of determining if a speaker is faulty is to substitute a speaker that is known to work correctly for the suspected problem speaker. If the "known good" speaker exhibits the same symptoms as the suspected problem speaker, use the information below to isolate the problem.

No Output

Possible Cause

Speaker cables

Action

"Re-seat" all connectors.

Substitute "known good" speaker cables.

Check solder joints.

Tighten set-screws on "banana" or Neutrik connectors.

Inspect cable for damage.

Amplifier

Inspect wire / connector for stray strands that may short - and + together.

Make sure the amplifier channel is being fed signal. Most amps have a

"signal input" LED to indicate the presence of a signal.

Repatch the speaker to an amplifier channel that is known to be working.

Intermittent

Possible Cause

Poor connections

Action

While it is possible for a faulty speaker to exhibit intermittent output, it's more likely that an output cable / connector is the problem.

Inspect all connectors and cables.

Look for damage to the insulation between the tip and sleeve of jacks.

Check the soldering on connectors.

Tighten the set-screws on "banana" or Neutrik connectors.

Constant noise, buzzing and/or humming

Possible Cause

*Faulty electronic device
in the signal chain*

Action

Any constant noise originates in the amplifier, mixer, signal processing, source devices, or line-level wiring.

Check and correct system grounding as required.

Check for noisy sources or electronic components.

Check wiring for faulty shielding.

Poor low-frequency output

Possible Cause

Improper Polarity

Action

When two speakers in close proximity to each other are connected out-of-polarity, they can partially cancel each other out – especially at low frequencies.

Check your speaker cables to be sure they are all identically wired and connected.

Check balanced-line signal cables to be sure they are all correctly wired.



Specs & Warranty

Specifications

Frequency Range	Sensitivity (1w/1m)	Nominal Coverage	Power Handling*	Max SPL**	Nominal Impedance	Dimension (HxWxD)	Weight
55-16 kHz	98 db	90°x60°	Avg. 225 W Peak 900 W	129 dB	8 ohms	686 x 430 x 444 mm 27 x 17 x 17.5 in	17.24 kg 38 lbs

* IEC filtered noise with 6 dB crest factor

** Calculated based on peak power handling and sensitivity

Warranty & Contacting JBL

These products are designed and backed by JBL Professional, the world leader in sound reinforcement. For complete JBL warranty information, to order replacement parts or to ask for clarifications to this manual, contact JBL Professional:

Within the United States contact: Applications Dept
JBL Professional
PO Box 2200
8400 Balboa Blvd.
Northridge, CA 91329

In the USA you may call Monday through Friday, 8:00 am to 5:00 pm Pacific Coast Time:
(818) 894-8850

In other areas throughout the world: Contact the JBL Professional Distributor in your country.

A list of JBL Professional Distributors and U.S. Service Centers can be obtained from the JBL Professional website: www.jblpro.com