

DMS 70 Quick Start Guide

1 Controls: DSR70 Quattro - DSR70 Dual - DPT70 DHT70 - DHT70 Perception

CONTENT	Page
Controls	1
Rack Assembly	2
Setting Up	2
Channel Recognition	2
Auto Correction	2
Channel Assignment	3
Registration	3
Tips & Tricks	3
Volume Configuration	4
FCC Statement	4

10 Volume Configuration - Audio-Mixer

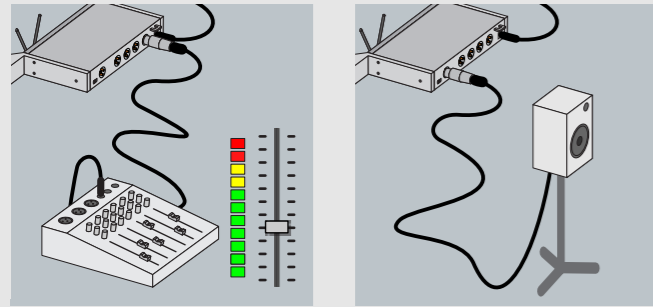

Adjust the audio level using the Volume-Poti on the instrument you have connected. For best results we recommend using the highest possible input level in order to obtain the best possible signal-to-noise ratio. However, even when someone is speaking loudly into the microphone you should take care to ensure that the level indicator never moves into the red zone; failure to do so can result in unpleasant distortion. Carefully increase the input level until the level indicator is just below the red zone.

11 FCC Statement

This equipment has been tested and found to comply with the limits for a Class B digital device, pursuant to Parts 74 and 15 of the FCC Rules. These limits are designed to provide reasonable protection against harmful interference in a residential installation. This equipment generates, uses, and can radiate radio frequency energy and, if not installed and used in accordance with the instructions, may cause harmful interference to radio communications. However, there is no guarantee that interference will not occur in a particular installation. If this equipment does cause harmful interference to radio or television reception, which can be determined by turning the equipment off and on, the user is encouraged to try to correct the interference by one or more of the following measures:

- Reorient or relocate the receiving antenna.
- Increase the separation between the equipment and the receiver.
- Connect the equipment into an outlet on a circuit different from that to which the receiver is connected.
- Consult the dealer or an experienced radio/TV technician for help.

Shielded cables and I/O cords must be used for this equipment to comply with the relevant FCC regulations. Changes or modifications not expressly approved in writing by AKG Acoustics may void the user's authority to operate this equipment. This device complies with Part 15 of the FCC Rules. Operation is subject to the following two conditions: (1) this device may not cause harmful interference, and (2) this device must accept any interference received, including interference that may cause undesired operation.

Weitere Informationen finden Sie in der Bedienungsanleitung als PDF Download unter www.akg.com.
Further information can be found in the operating instructions as a PDF download from www.akg.com.
Pour toutes informations complémentaires, consulter la Notice d'utilisation à télécharger au format PDF sur le site www.akg.com.
Ulteriori informazioni sono disponibili nelle istruzioni per l'uso, scaricabili in formato PDF dal sito www.akg.com.
Obtendrá más información en el manual de funcionamiento que puede descargar en formato PDF en www.akg.com.
Para mais informações transfira o manual de instruções em PDF a partir do site www.akg.com.

Dieses Produkt entspricht den in der Konformitätserklärung angegebenen Normen. Sie können die Konformitätserklärung auf <http://www.akg.com> oder per E-Mail an sales@akg.com anfordern.
This product conforms to the standards listed in the Declaration of Conformity. To order a free copy of the Declaration of Conformity, visit <http://www.akg.com> or contact sales@akg.com.
Ce produit est conforme aux normes citées dans la Déclaration de Conformité, dont vous pouvez prendre connaissance en consultant le site <http://www.akg.com> ou en adressant un e-mail à sales@akg.com.
Questo prodotto corrisponde alle norme elencate nella dichiarazione di conformità, che è disponibile al sito <http://www.akg.com> oppure all'indirizzo email sales@akg.com.
Este aparato corresponde a las normas citadas en la declaración de conformidad. Esta última está disponible en el sitio <http://www.akg.com> o puede ser solicitada al correo electrónico sales@akg.com.
Este produto corresponde às normas citadas na declaração de conformidade, que pode pedir na nossa página da web <http://www.akg.com>, ou enviando-nos um email para sales@akg.com.



Made in China (P.R.C.)

02/12/9100 U 13820

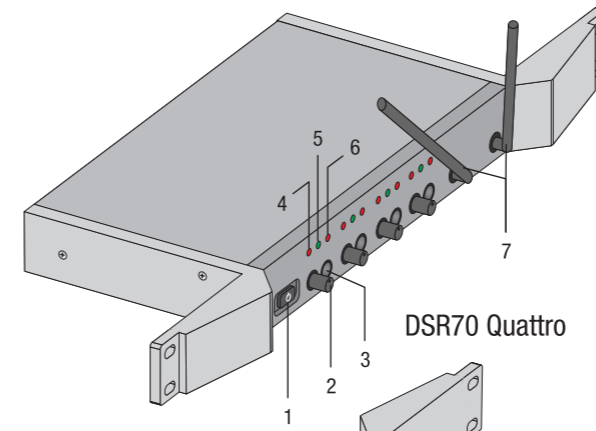

DSR70 Quattro

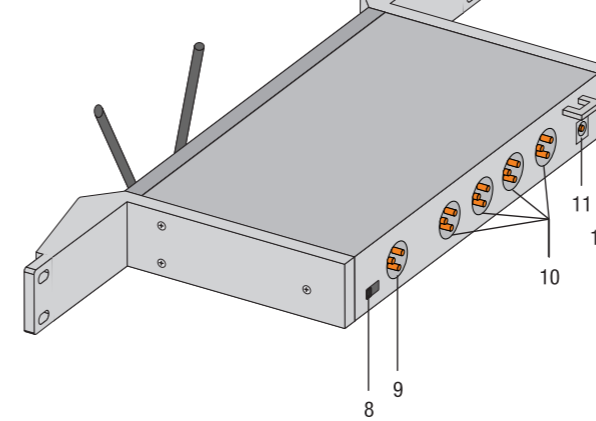

DSR70 Dual

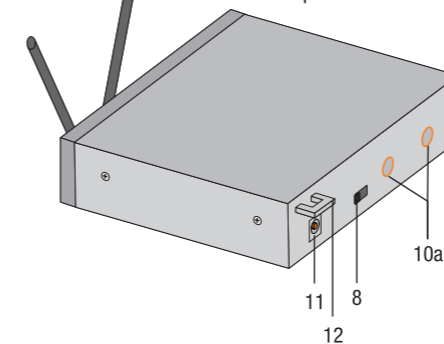
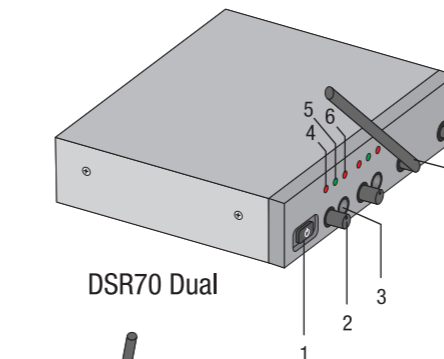

DHT70 and DHT70 Perception

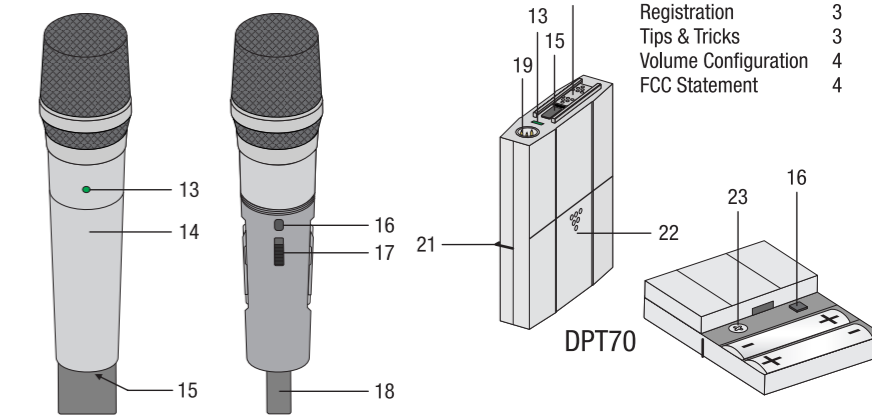

- On/Off button**
This button is lit green when the receiver is switched on and ready for use. Switching off the receiver switches off all transmitters connected to this receiver.
- VOLUME-poti**
The VOLUME potentiometers influence the four separate channels (10) and the sum output (9).
- CONNECT button**
- press briefly: checks the transmitter assigned to this channel.
- hold down (approximately 2 seconds): to assign a transmitter to a free channel or to register a transmitter on this channel.
- LOW BATT. LED** lights up when the batteries of the transmitter registered on this channel are low. If the LED starts to light red the batteries will be discharged within approximately one hour. Replace batteries.
- STATUS LED** lights up when a registered transmitter is active and ready to operate on this channel; flashes during channel identification and channel assignment.
- CLIP LED** lights up if the audio level is too high.
- Antennas:** The best transmission and reception performances are achieved when the antennas are pointing upwards in the "normal position" (see diagram). Range: Indoor 30m NLOS, Outdoor 50m LOS
- AUTO CORRECTION** switch for internal error correction.
- SUM OUT / BALANCED** for connection of an active monitor
- CHANNEL OUT / BALANCED (x4)** 3-pin XLR socket for connection to a microphone input of a mixer or amplifier
- CHANNEL OUT / 6,35mm jack (x2)** for connection to a microphone input of a mixer or amplifier
- Direct current in 12 V, 0.5 A**
- Strain relief for the power cable**
- STATUS LED**
- lit green when the transmitter is connected to the receiver
- flashing green: no radio contact between transmitter and receiver
- lit red: replace batteries
- Battery cover for DHT70**
- On/Off button**
The transmitter is ready for use as soon as it is switched on.
After two minutes without radio contact with the receiver (receiver is OFF, power failure, transmitter is outside range) the connected transmitter switches off automatically.
- CONNECT button**
- press briefly: Check the assigned channel on the receiver.
- hold down (approximately 2 seconds): Assign this transmitter to a free channel on the receiver.
- 15 / 16 On/Off / Connect button:** Use the On/Off (15) and Connect button (16) to register this transmitter to a free channel on the receiver.
- GAIN** slide to adjust input sensitivity
- Digital diversity antenna system**
- Mini-XLR input jack**
- Slide cover**
- Belt clip**
- Battery cover for DPT70**
- GAIN potentiometer to adjust input level**

www.akg.com

AKG Acoustics GmbH
Lemböckgasse 21-25, 1230 Vienna / AUSTRIA, phone: + 43 1 86654 0
e-mail: sales@akg.com

For other products and distributors worldwide visit www.akg.com or www.harman.com

Specifications subject to change without notice. Technische Änderungen vorbehalten. Ces caractéristiques sont susceptibles de modifications. Ci riserviamo il diritto di effettuare modifiche tecniche. Nos reservamos el derecho de introducir modificaciones técnicas. Especificações sujeitas a mudanças sem aviso prévio.

A Harman International Company

AKG SOUNDS BETTER



2 Rack Assembly

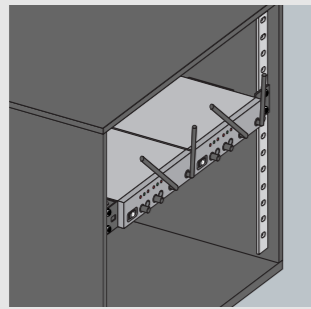

The rack mount unit RMU 40 PRO is available separately as an accessory for the DSR70 Dual.

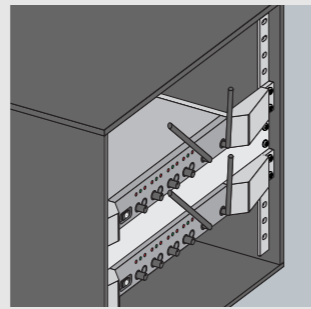

Fitting the DSR70 Quattro in a 19" rack. Leave one unit space free between two receivers in the rack.

3 Setting Up Receivers

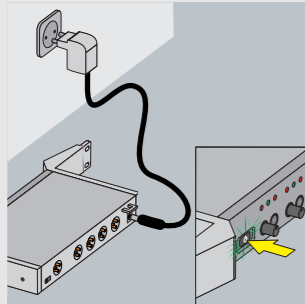

Connect receiver to the mains.

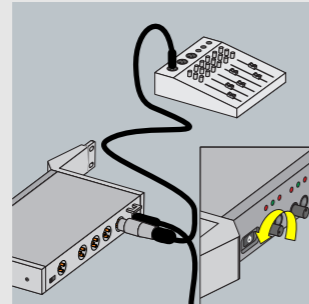

Reduce audio level (2) and connect receiver to balanced input (10/10a).

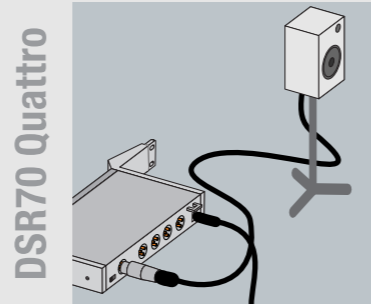

Connect the sum output (9) to a monitor.

4 Setting Up Transmitters

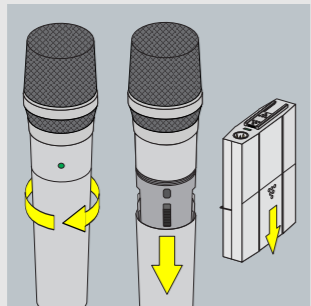

Remove battery cover (14 / 22).

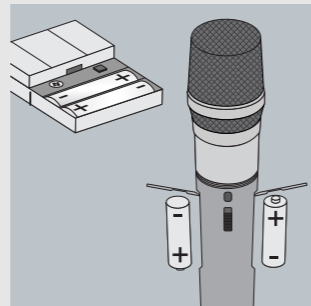

Insert batteries.

4 Setting Up Transmitters

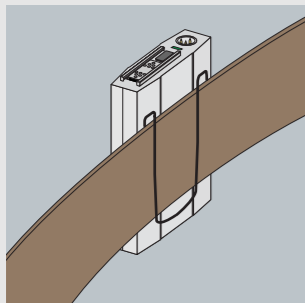

Attach bodypack transmitter to a belt with the battery compartment facing away from the body.

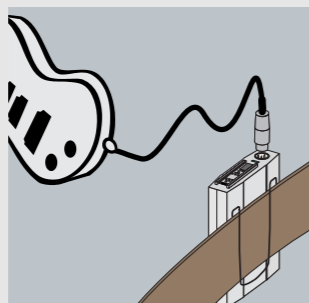

Connect instrument or microphone to the mini XLR connector of the bodypack transmitter.

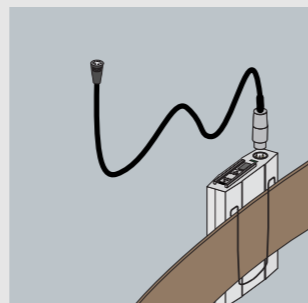

5 Channel Recognition

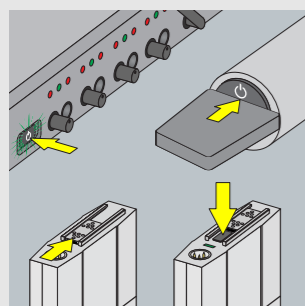

Switch on receiver (1) and transmitter (15).

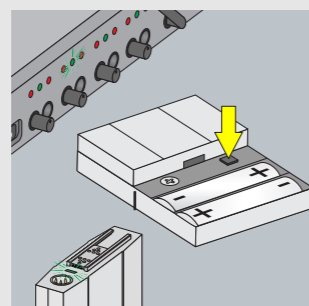

Check channel by pressing **CONNECT** on the transmitter (16) or receiver (3). The **STATUS LEDs** of the transmitter (13) and receiver (5) on the same channel will flash.

6 Auto Correction

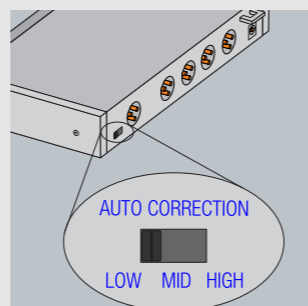

Set **AUTO CORRECTION** (8) to **LOW** in normal operating mode. If there is interference in the 2.4 GHz ISM frequency range, set **AUTO CORRECTION** to **MID** or **HIGH**.

7 Channel Assignment

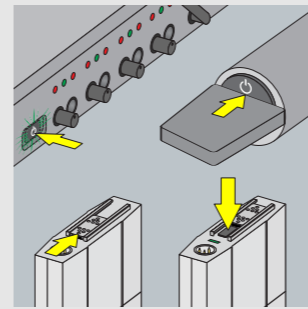

Switch on receiver (15) and transmitter (1).

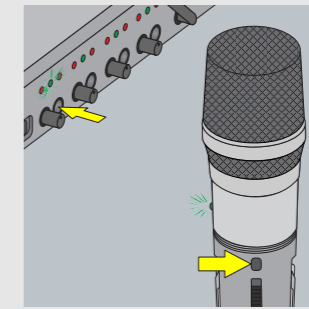

Assignment can be started from both the transmitter and receiver. In this example, it is started from the receiver. Press **CONNECT** (3) on a free channel of the receiver and hold down until the **STATUS LED** (5) starts to flash after approximately 2 seconds. Press **CONNECT** (16) on the transmitter until **STATUS LED** (13) lights up green. The **STATUS LEDs** on the transmitter (13) and the receiver (5) light up green once assignment has been successful.

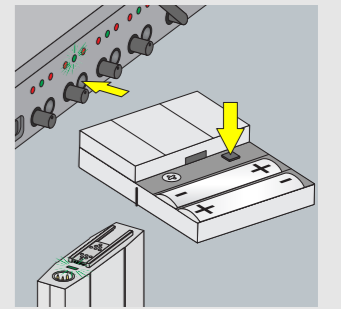

8 Registration

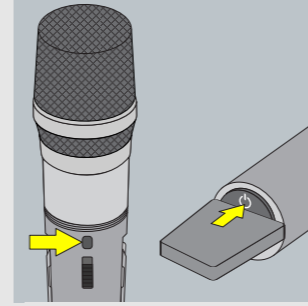

Registration can be started from both the transmitter and receiver. In this example it is started from the transmitter. Switch on the receiver. Press **CONNECT** (16) along with **ON/OFF** (15) on the transmitter until **STATUS LED** (13) starts to flash quickly.

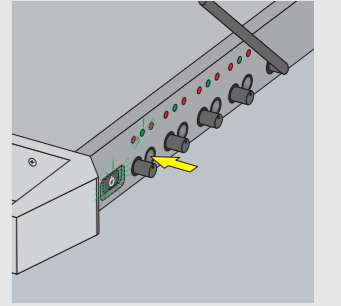
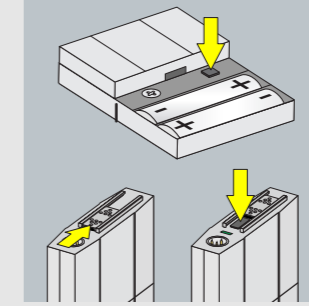

Hold down **CONNECT** (3) on a free channel of the receiver until the **STATUS LED** (5) lights up green. The **STATUS LEDs** on the transmitter (13) and the receiver (5) light up green after successful registration.

9 Tips & Tricks

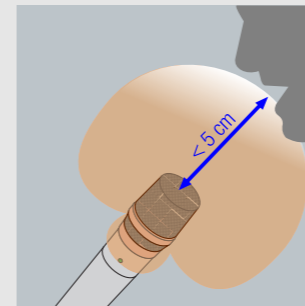

In the case of microphones with a hypercardioid polar pattern, most sound attenuation occurs at 180°. These microphones should therefore preferably be used where there is an interference noise source or a loudspeaker directly opposite the speaker. Holding the microphone less than 5 cm from your mouth will give your voice a voluminous and punchy quality.

9 Tips & Tricks

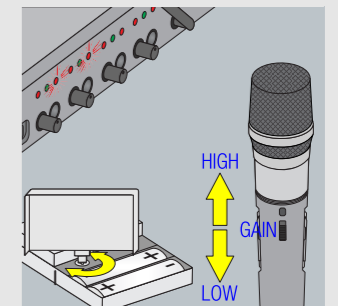

Adjust the input sensitivity on the DPT70 pocket transmitter using the screwdriver included in the battery compartment cover; on the DHT70 manual transmitter, use the slide control: If **CLIP** lights up frequently, set the **GAIN** on the DHT70 to **LOW** and reduce the potentiometer setting on the DPT70.

9 Tips & Tricks

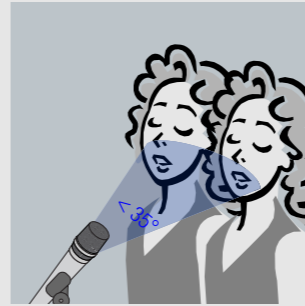

Never let more than 2 people sing into one microphone. The angle of incidence should never be more than 35°!