

# *Ampeg*

## V-4B

### Bass Guitar Amplifier



## Owner's Manual



## TABLE OF CONTENTS

Important Safety Instructions .....	2
Introduction / Features .....	4
The Front Panel .....	5
The Rear Panel .....	7
Important Information About Tubes.....	9
Troubleshooting / Block Diagram .....	14
Technical Specifications / Service Information.....	15

### IMPORTANT SAFETY INSTRUCTIONS

1. Read these instructions.
2. Keep these instructions.
3. Heed all warnings.
4. Follow all instructions.
5. Do not use this apparatus near water.
6. Clean only with a dry cloth.
7. Do not block any ventilation openings. Install in accordance with the manufacturer's instructions.
8. Do not install near any heat sources such as radiators, heat registers, stoves, or other apparatus (including amplifiers) that produce heat.
9. Do not defeat the safety purpose of the polarized or grounding-type plug. A polarized plug has two blades with one wider than the other. A grounding-type plug has two blades and a third grounding prong. The wide blade or the third prong are provided for your safety. If the provided plug does not fit into your outlet, consult an electrician for replacement of the obsolete outlet.
10. Protect the power cord from being walked on or pinched particularly at plugs, convenience receptacles, and the point where they exit from the apparatus.
11. Only use attachments/accessories specified by the manufacturer.
12. Use only with a cart, stand, tripod, bracket, or table specified by the manufacturer, or sold with the apparatus. When a cart is used, use caution when moving the cart/apparatus combination to avoid injury from tip-over.
13. Unplug this apparatus during lightning storms or when unused for long periods of time.
14. Refer all servicing to qualified service personnel. Servicing is required when the



apparatus has been damaged in any way, such as power-supply cord or plug is damaged, liquid has been spilled or objects have fallen into the apparatus, the apparatus has been exposed to rain or moisture, does not operate normally, or has been dropped.

15. Do not overload wall outlets and extension cords as this can result in a risk of fire or electric shock.

16. This apparatus shall not be exposed to dripping or splashing, and no object filled with liquids, such as vases or beer glasses, shall be placed on the apparatus.

17. This apparatus has been designed with Class-I construction and must be connected to a mains socket outlet with a protective earthing connection (the third grounding prong).

18. The MAINS plug or an appliance coupler is used as the disconnect device, so the disconnect device shall remain readily operable.

19. For the terminals marked with symbol of “⚡” may be of sufficient magnitude to constitute a risk of electric shock. The external wiring connected to the terminals requires installation by an instructed person or the used of ready-made leads or cords.

	<b>CAUTION AVIS</b>	
RISK OF ELECTRIC SHOCK. DO NOT OPEN RISQUE DE CHOC ELECTRIQUE. NE PAS OUVRI		
CAUTION: TO REDUCE THE RISK OF ELECTRIC SHOCK DO NOT REMOVE COVER (OR BACK) NO USER-SERVICEABLE PARTS INSIDE. REFER SERVICING TO QUALIFIED PERSONNEL		
ATTENTION: POUR EVITER LES RISQUES DE CHOC ELECTRIQUE, NE PAS ENLEVER LE COUVERCLE. AUCUN ENTRETIEN DE PIECES INTERIEURES PAR L'USAGER. CONFIER L'ENTRETIEN AU PERSONNEL QUALIFIE		
AVIS: POUR EVITER LES RISQUES D'INCENDIE OU D'ELECTROCUTION, N'EXPOSEZ PAS CET ARTICLE A LA PLUIE OU A L'UMIDITE.		



The lightning flash with arrowhead symbol within an equilateral triangle is intended to alert the user to the presence of uninsulated "dangerous voltage" within the product's enclosure, that may be of sufficient magnitude to constitute a risk of electric shock to persons.  
Le symbole éclair avec point de flèche à l'intérieur d'un triangle équilatéral est utilisé pour alerter l'utilisateur de la présence à l'intérieur du coffret de "voltage dangereux" non isolé d'amplieur suffisante pour constituer un risque d'électrocution.



The exclamation point within an equilateral triangle is intended to alert the user of the presence of important operating and maintenance (servicing) instructions in the literature accompanying the appliance.  
Le point d'exclamation à l'intérieur d'un triangle équilatéral est employé pour alerter les utilisateurs de la présence d'instructions importantes pour le fonctionnement et l'entretien (service) dans le livret d'instruction accompagnant l'appareil.



**NOTE:** This equipment has been tested and found to comply with the limits for a Class B digital device, pursuant to part 15 of the FCC Rules. These limits are designed to provide reasonable protection against harmful interference in a residential installation. This equipment generates, uses, and can radiate radio frequency energy and, if not installed and used in accordance with the instructions, may cause harmful interference to radio communications. However, there is no guarantee that interference will not occur in a particular installation. If this equipment does cause harmful interference to radio or television reception, which can be determined by turning the equipment off and on, the user is encouraged to try to correct the interference by one or more of the following measures:

- Reorient or relocate the receiving antenna.
- Increase the separation between the equipment and the receiver.
- Connect the equipment into an outlet on a circuit different from that to which the receiver is connected.
- Consult the dealer or an experienced radio/TV technician for help.

**CAUTION:** Changes or modifications to this device not expressly approved by LOUD Technologies Inc. could void the user's authority to operate the equipment under FCC rules.

This apparatus does not exceed the Class A/Class B (whichever is applicable) limits for radio noise emissions from digital apparatus as set out in the radio interference regulations of the Canadian Department of Communications.

### CONSIGNES DE SECURITE IMPORTANTES

- LIRE, SUIVRE TOUTES LES INSTRUCTIONS ET LES PRECAUTIONS D'UTILISATION
- NE PAS UTILISER PROCHE D'UNE SOURCE DE CHALEUR ET NE PAS BLOQUER OU OBSTRUER LE SYSTEME DE VENTILATION SUR CET APPAREIL. POUR UNE UTILISATION CONFORME, CET APPAREIL NECESSITE ENVIRON 7CM D'ESPACE BIEN VENTILE AUTOUR DE SON SYSTEME DE REFROIDISSEMENT, AINSI QU'UN COURANT D'AIR FRAIS CONSTANT
- NE PAS UTILISER CET APPAREIL PROCHE D'UNE SOURCE LIQUIDE
- NETTOYER SEULEMENT A L'AIDE D'UN CHIFFON DOUX ET SEC ET NE PAS UTILISER DE PRODUITS MENAGERS
- CONNECTER UNIQUEMENT LE CABLE D'ALIMENTATION FOURNI SUR UNE PRISE AVEC MISE A LA TERRE, ET COMPATIBLE AVEC LA TENSION, L'INTENSITE ET LA FREQUENCE REQUISES INDIQUEES SUR LA FACE ARRIERE DE L'APPAREIL
- S'ASSURER DE NE PAS MARCHER, PLIER OU TIRER SUR LE CABLE D'ALIMENTATION
- DEBRANCHER L'APPAREIL LORS D'UNE TEMPETE OU LORS D'UNE TRES LONGUE PERIODE DE NON UTILISATION
- UTILISER UNIQUEMENT DES ACCESSOIRES SPECIFIES PAR LE FABRICANT POUR UNE UTILISATION EN TOUTE SECURITE ET POUR EVITER DES BLESSURES
- **ATTENTION:** AFIN DE PREVENIR TOUT RISQUE DE CHOC ELECTRIQUES OU DE DEBUT D'INCENDIE, NE PAS EXPOSER CET APPAREIL A LA PLUIE ET A L'HUMIDITE
- TOUT ENTRETIEN DOIT ETRE FAIT PAR UN TECHNICIEN QUALIFIE
- NOS AMPLIFICATEURS PEUVENT PRODUIRE DE TRES HAUTES PRESSIONS ACOUSTIQUES QUI PEUVENT CAUSER DES DOMMAGES AUDITIFS PERMANENTS OU DEFINITIFS. L'UTILISER AVEC UNE GRANDE PRECAUTION EST CONSEILLE ET DES PROTECTIONS AUDITIVES SONT RECOMMANDEES POUR UNE UTILISATION A FORT VOLUME.
- **ATTENTION:** CET APPAREIL REQUIERT UNE PRISE MURALE AVEC MISE A LA TERRE, AUX NORMES ACTUELLES ET COMPATIBLE AVEC LES SPECIFICATIONS ELECTRIQUES SE TROUVANT EN FACE ARRIERE DE L'APPAREIL. LA PRISE ELECTRIQUE DOIT ETRE NORMES ACCESSIBLE POUR DEBRANCHER L'APPAREIL EN CAS DE DEFAUT PENDANT L'UTILISATION
- CET APPAREIL DOIT ETRE DEBRANCHE SI IL N'EST PAS UTILISE

Elimination correcte du produit : Ce symbole indique que ce produit ne doit pas être éliminé avec les ordures ménagères, comme le prévoit la directive WEEE (2002/96/EC) et votre loi nationale.

Ce produit doit être remis à un site de recyclage des déchets électriques et des équipements électroniques (EEE).

Un mauvais recyclage de ce type de déchet peut avoir de possibles impacts négatifs sur l'environnement et la santé humaine dus aux émanations de substances.

Dans un même temps, votre coopération à un recyclage correct de ce produit contribuera à la bonne utilisation des ressources naturelles.

Pour connaître l'endroit où il est possible de recycler ces équipements, merci de contacter votre mairie, les services de recyclages ou le service des déchets ménagers.



**Correct disposal of this product:** This symbol indicates that this product should not be disposed of with your household waste, according to the WEEE directive (2002/96/EC) and your national law. This product should be handed over to an authorized collection site for recycling waste electrical and electronic equipment (EEE). Improper handling of this type of waste could have a possible negative impact on the environment and human health due to potentially hazardous substances that are generally associated with EEE. At the same time, your cooperation in the correct disposal of this product will contribute to the effective usage of natural resources. For more information about where you can drop off your waste equipment for recycling, please contact your local city office, waste authority, or your household waste disposal service.

**ATTENTION** — Le présent appareil numérique n'émet pas de bruits radioélectriques dépassant les limites applicables aux appareils numériques de class A/de class B (selon le cas) prescrites dans le règlement sur le brouillage radioélectrique édicté par les ministere des communications du Canada.

Exposure to extremely high noise levels may cause permanent hearing loss. Individuals vary considerably in susceptibility to noise-induced hearing loss, but nearly everyone will lose some hearing if exposed to sufficiently intense noise for a period of time. The U.S. Government's Occupational Safety and Health Administration (OSHA) has specified the permissible noise level exposures shown in the following chart.

According to OSHA, any exposure in excess of these permissible limits could result in some hearing loss. To ensure against potentially dangerous exposure to high sound pressure levels, it is recommended that all persons exposed to equipment capable of producing high sound pressure levels use hearing protectors while the equipment is in operation. Ear plugs or protectors in the ear canals or over the ears must be worn when operating the equipment in order to prevent permanent hearing loss if exposure is in excess of the limits set forth here:

Duration, per day in hours	Sound Level dBA, Slow Response	Typical Example
8	90	Duo in small club
6	92	
4	95	Subway Train
3	97	
2	100	Very loud classical music
1.5	102	
1	105	The boss screaming at his minions about manual deadlines
0.5	110	
0.25 or less	115	Lowest parts at a rock concert



### Introduction

Congratulations on your purchase of the Ampeg V-4B 100W all-tube bass head.

Based on the original from 1971, the Ampeg V-4B 100W all-tube head embodies the legendary tone of the classic V-4B in a tough-as-nails package, ready to take the stage with the flexible output control and pure vintage Ampeg grind you crave at volume levels ideal for modern venues and applications.

With a built-in suspension system, metal chassis, and 15 mm birch cabinet enclosure, the V-4B will go anywhere your tone needs to.

Best of luck in all of your musical endeavors!

Sincerely,

The dedicated team at Ampeg

### Features

- RMS power output: 100W
- Chassis Suspension System
- Preamp tube: 2 x 12AX7
- Driver tube: 1 x 12AX7, 1 x 12AU7
- Power amp tube: 4 x 6L6GC
- Tone controls: Bass, mid, treble (3-position midrange rocker, ultra hi / ultra lo)
- Balanced direct out
- -15 dB input
- Dimensions (H x W x D) 10.8" x 23.8" x 11"
- Handling weight: 41 lb [18.6 kg]



**Like us**



**Follow us**



**Watch our dang videos**



## The Front Panel

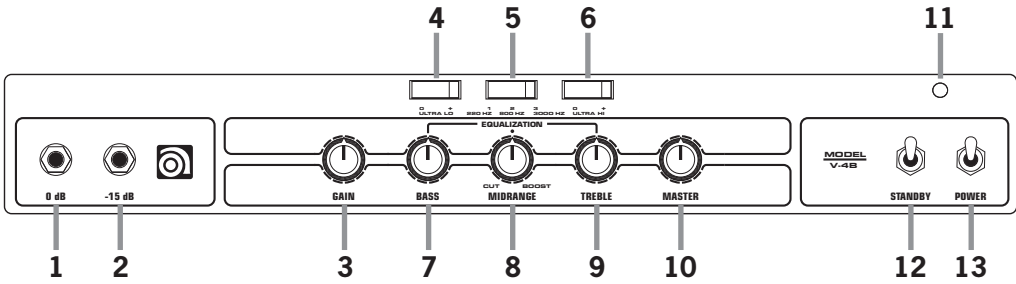

1. **0 dB INPUT:** The signal output from a passive instrument may be connected to this 1/4" input by means of a shielded instrument cable.
2. **-15 dB INPUT:** The signal output from an active instrument may be connected to this 1/4" input by means of a shielded instrument cable.
3. **GAIN:** This control adjusts the basic level of signal in the preamp.
4. **ULTRA LO:** This switch, when engaged [right side down], enhances the amount of low frequency output by 2 dB at 40 Hz and -11 dB cut at 500 Hz.
5. **1•2•3 SWITCH:** This switch selects the frequency that will be affected by the midrange control [8]. The available frequencies are:  
Left = 220 Hz  
Center = 800 Hz  
Right = 3 kHz
6. **ULTRA HI:** This switch, when engaged [right side down], enhances the amount of high frequency output by 7 dB at 8 kHz.
7. **BASS:** Use this to adjust the low frequency level of the amplifier. This provides up to 13 dB of boost, or 12 dB of cut at 40 Hz. The low frequency output is flat at the center position.
8. **MIDRANGE:** Use this to adjust the midrange frequency level of the amplifier. This provides up to 11 dB of boost, or 21 dB of cut at the selected frequency [5]. The midrange frequency output is flat at the center position. Rotate the control counter-clockwise for a "contoured" sound (more distant, less midrange output) or clockwise for a sound which really cuts through.
9. **TREBLE:** Use this to adjust the high frequency level of the amplifier. This provides up to 14 dB of boost, or 17 dB of cut at 4 kHz. The high frequency output is flat at the center position.
10. **MASTER:** Use this to control the overall output level. It affects the speaker outputs and the preamp output [16]. Use it wisely, and turn it down when making connections or trying something new.



### The Front Panel continued...

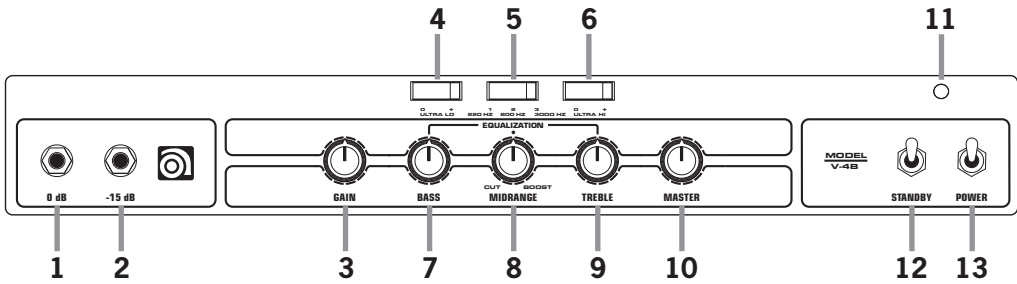

**11. STANDBY/POWER LED:** This is a multi-function LED. In Standby mode, it glows red and in the On mode it glows green.

**12. STANDBY SWITCH:** Use this switch to turn the standby power on or off. Press the top of the switch to turn the standby on. The standby mode allows the tubes to warm or remain warm without high voltage being applied to them. This extends tube life. This switch should be OFF when first turning the amplifier on. Allow the unit to warm up for at least 60 seconds before switching to the ON position. During short periods of non-use, the amp should be put into standby mode.

**13. POWER SWITCH:** Use this switch to turn the overall system power on or off. Press the top of the switch to turn on the power. The power switch should be engaged prior to the standby switch (as mentioned to the left, #12).



## The Rear Panel

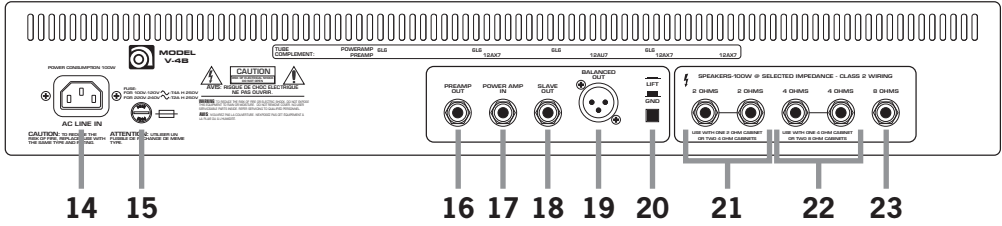

**14. AC LINE IN:** This is where you connect the supplied AC power cord. Plug the male end of the cord into a grounded AC outlet.

 **DO NOT DEFEAT THE GROUND PRONG OF THE AC PLUG!**

**15. FUSE:** This protects the unit from damage due to overload conditions or power line surges. If the fuse blows, replace it only with the same size and type.

**16. PREAMP OUT:** This jack is a direct post master preamp output for use with an external power amp. Connect the external amp's input to this jack using a shielded instrument cable.

**17. POWER AMP IN:** This jack connects directly to the internal power amp for use with an external preamp. When using an external source, connect the OUTPUT of the source to this jack using a shielded instrument cable to feed the signal into the power amp section. The internal signal is disconnected when a plug is inserted into this jack.

**18. SLAVE OUT:** This jack receives the same signal that is being sent to the power amp. It is useful for powering another amp (slave) from this unit's preamp.

**19. BALANCED OUT:** This XLR jack is the output at the power amp in. Thus, it will include any processing done in the Preamp Out/Power Amp In loop. This signal may be used to feed an external power amplifier, mixing console or house PA system.

The lift / gnd switch [20] is available to reduce any noise that may occur at the balanced output.

**20. LIFT / GND:** When this switch is engaged, it connects the ground connection at the balanced output jack [19]. This may help reduce residual hum and buzz sometimes picked up in line out signal cables.



### The Rear Panel continued...

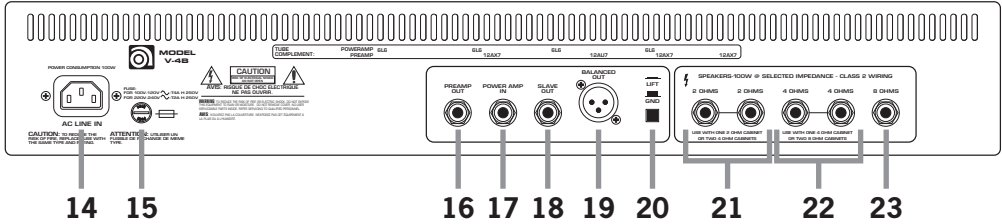

**WARNING!** Never turn on or use the amplifier without a load or speaker connected to the amplifier. **ALWAYS** use a good quality (non-shielded) speaker cable. Never use (shielded) instrument cable. **ALWAYS** match the amplifier's speaker output impedance to the impedance of the speaker that is being used. Use only one type impedance output at a time. If more than one speaker is connected at the same time, make sure they all have the same impedance rating. Never use two or more cabinets with different impedance ratings. This will create an unbalanced load. When using multiple speaker cabinets (with the same impedance rating), match the total load impedance of the speaker cabinets to the speaker output of the amplifier.

**SPEAKER CABINET IMPEDANCE** divided by **NUMBER OF CABINETS** = **TOTAL IMPEDANCE**

- 8 Ω cabs / 2 cabs = 4 Ω impedance. For this application use the 4 Ω output jacks.
- 8 Ω cab / 1 cab = 8 Ω impedance. For this application use the 8 Ω speaker jack.
- 4 Ω cabs / 2 cabs = 2 Ω impedance. For this application use the 2 Ω output jacks.
- 4 Ω cab / 1 cab = 4 Ω impedance. For this application use the 4 Ω speaker jack.
- 2 Ω cabs / 1 cab = 2 Ω impedance. For this application use the 2 Ω output jack.

**21. 2 OHMS:** The two 2 Ω speaker output jacks are wired in parallel. Use a single jack when using one 2 Ω speaker cabinet. Use both speaker jacks when using two 4 Ω speaker cabinets. If you have four 8 Ω cabinets with parallel speaker jacks, you can link all four 8 Ω cabinets in a parallel wiring configuration, totaling a 2 Ω load.

**22. 4 OHMS:** The two 4 Ω speaker output jacks are wired in parallel. Use a single jack when using one 4 Ω speaker cabinet. Use both speaker jacks when using two 8 Ω speaker cabinets.

**23. 8 OHMS:** The 8 Ω speaker output jack is designated for 8 Ω speaker cabinets only.





## **Important information about tubes**

### ***A brief history of the tube:***

In 1883, Thomas Edison discovered that electrons would flow from a suspended filament when enclosed in an evacuated lamp. Years later, in 1905, John Ambrose Fleming expanded on Edison's discovery and created the "Fleming Valve". Then, in 1907, Dr. Lee de Forest added a third component – the grid – to "Fleming's Valve" and the vacuum tube was a fact of life. The door to electronic amplification was now open.

During World War II, data gleaned from their intensive research on the detectors used in radar systems led Bell Telephone Laboratories to the invention of the transistor. This reliable little device gained quick support as the new component for amplification. The death of the vacuum tube seemed imminent as designers, scientists, and engineers reveled in the idea of replacing large, fragile glass tubes with these small, solid-state devices.

However, there were (and still are) many serious listeners who realized that the sound produced by a "transistor" amplifier is significantly different from that produced by a tube amplifier with identical design specifications. They considered the sound produced by these new solid-state devices to be hard, brittle, and lifeless. It was determined that solid-state devices produced a less musical set of harmonics than tubes. When pushed past their limits, they tend to mute the tone and emphasize the distortion.

Tubes, on the other hand, produce a more musical set of harmonics, the intensity of which may be controlled by the player. This characteristic adds warmth and definition to the sound which has become the hallmark of tube amplifiers. When tubes are driven into clipping, the harmonic overtones can be both sweet and pleasing or intense and penetrating, depending on the musician's taste and playing technique.

Over the years, application engineers have designed a number of outstanding solid-state amplifiers that sound very, very good. Some use special circuitry which enables them to simulate distortion characteristics of a tube amplifier. However, the tube amplifier, still held in the highest esteem by many musicians, offers a classic "vintage" sound in a contemporary market.

### ***Tube types and usage:***

Tube amplifiers are based primarily on two types of tubes – preamplifier tubes and power tubes. The tubes used in preamplifiers (12AX7, 12AU7, 12AT7, etc.) are smaller than the power tubes. These tubes amplify the signal from the instrument and shape the sound. They are inherently microphonic (mechanically pick up and transmit external noises). Since these tubes are used in the critical first stages of a tube amplifier's circuitry, it is very important that any replacements are high-quality, low noise/low microphonic tubes for this application. Although tubes of this quality may be difficult to find and typically cost more than "off-the-shelf" tubes, the improvement in performance is worth the investment.

Preamplifier tubes are also used to drive the power tubes. When used in this application, a 12AX7 will produce a more distorted tone than a 12AT7 which produces a clearer, sweeter sound. A 12AU7 is even cleaner and brighter than a 12AT7, giving more definition to the sound. It is possible to change the sound of the amplifier by changing the type of preamp and/or driver tubes. When making any modification to your equipment, it is highly recommended that you consult with a qualified service center.



### Tube types and usage continued...

**Power tubes** are the largest tubes used in an amplifier, generate the most heat and wear out the fastest. These tubes convert the low-level, conditioned signal from the preamplifier into a level that is sufficient to drive the speakers. There are several types of power tubes available, each of which offers a different performance/sound characteristic. For example, the EL34 power tube produces a great classic rock sound. When an EL34 is driven into distortion, it produces a unique sound ("crunch"). When compared to the 6L6, the EL34 distorts more quickly, exhibits a "looser" low-end response and produces more harmonics at mid and high frequencies ("creamier" sound). These differences become more noticeable at higher volumes.

The 6L6 tubes produce a big low-end thump and have very good dynamic range. They offer a more traditional "American Rock" sound. The 6V6 tubes produce a creamy sound with nice distortion. On the other hand, the KT88 produces a big low-end but sounds more like an EL34 in the mid and high frequencies.

The 6550 power tubes are more rugged and stay cleaner sounding, even at full power. When they do distort, the sound produced is more solid and has a tighter low end; more of a "heavy metal" type distortion with lots of power.

Some power tubes are available in matched sets. These tubes have been extensively tested for optimum performance and longevity.

When replacing power tubes, please replace them with a tested, matched pair and have the amp rebiased by a qualified service center. It is possible to change the sound of the amplifier by changing the type of power tubes. When making any modification to your equipment, it is highly recommended that you consult with a qualified service center.

### ***The nature of tubes – why (and when) to replace them:***

Tubes are made up of a number of fragile mechanical components that are vacuum-sealed in a glass envelope or bubble. The tube's longevity is based on a number of factors which include how hard and often the amplifier is played, vibration from the speakers, road travel, repeated setup and tear down, etc.

Any time you notice a change in the amplifier's performance, check the tubes first.

If it's been awhile since the tubes were replaced and the sound from the amplifier lacks punch, fades in and out, loses highs or lows or produces unusual sounds, the power tubes probably need to be replaced. If the amplifier squeals, makes noise, loses gain, starts to hum, lacks "sensitivity", or feels as if it is working against you, the preamplifier tubes may need to be replaced.

The power tubes are subjected to considerably more stress than the preamplifier tubes. Consequently, they almost always fail/degrade first. If deteriorating power tubes aren't replaced, they will ultimately fail. Depending on the failure mode, they may even cause severe damage to the audio output transformer and/or other components in the amplifier. Replacing the tubes before they fail completely has the potential to save time, money and other unwanted troubles. Since power tubes work together in an amplifier, it is crucial that they (if there is more than one) be replaced by a matched set. If you are on the road a lot, we recommend that you carry a spare matched set of replacement power tubes and their associated driver tubes.

After turning off the power and disconnecting the amplifier from the power source, carefully check the tubes (in bright light) for cracks, white spots inside the glass or any apparent damage. Then, with the power on, view the tubes in a darkened room. Look for the preamplifier tubes that do not glow at all or power tubes that glow excessively red.



### The nature of tubes continued...

Whenever replacing power tube(s):

- Always have the amplifier's bias voltage checked by a qualified service center. Improper bias voltage will cause degradation in performance and possibly damage tubes and/or the amplifier. (See the section below titled "The importance of proper biasing" for more information on this subject).
- We highly recommend replacing the driver tube(s), as well. The driver tube determines the shape and amplitude of the signal applied to the power tube(s) and has to work almost as hard as the power tube(s).

You may check the preamplifier tubes for microphonics by turning the amplifier on, turning up the gain and tapping lightly on each tube with the end of a pencil or a chopstick. You will be able to hear the tapping through the speakers, which is normal. It is not normal for a tube to ring like a bell after it is tapped. If it does ring, then it is microphonic and should be replaced. Remember to use only high quality, low microphonic tubes in the preamplifier section.

Even though power tubes are rarely microphonic, they should be checked, anyway. The power tubes may be checked for microphonics just like the preamp tubes.

In the case of very high gain amps, you may be able to reduce the amount of noise generated by simply swapping the preamp tubes around.

### ***The importance of proper biasing:***

For the best performance and longest tube life, proper biasing is imperative. Bias is the negative voltage which is applied to the power tube's control grid to set the level of idle current. We cannot over emphasize the difference in warmth of tone and dynamic response that come with proper biasing. If the bias is set too high (overbiased), the sound from the amp will be distorted at all levels. If the bias is set too low (underbiased), the power tubes will run hot (the plates inside the tubes may glow red due to excessive heat) and the sound from the amplifier will lack power and punch. The excessive heat greatly reduces tube life – from a few days to as little as a few hours in extreme cases. Setting the bias on the amp is like setting the idle on a car. If it's too high or hot, it's running away with you and if it's too low or cold it will choke when you step on it.

The bias is adjusted at the factory in accordance with the type of power tube(s) installed in your amplifier. It is important to point out that tubes of the same type and specification typically exhibit different performance characteristics. Consequently, whenever power tubes are replaced, the bias voltage must be checked and re-adjusted to accommodate the operating parameters of the replacement tubes. The bias adjustment should be performed only by qualified service personnel with the proper, calibrated test equipment.



### Survival Tips for Tube Amplifiers

To prolong tube life, observe these tips and recommendations:

- Match the impedance of the speaker cabinet(s) to the amplifier. Improper impedance matching will contribute to early tube degradation and may cause premature tube failure.
- Make sure the speaker(s) are properly connected prior to turning on the amplifier.
- After playing the amplifier, allow sufficient time for it to properly cool down prior to moving it. A properly cooled amplifier prolongs tube life due to the internal components being less susceptible to the damage caused by vibration.
- Allow the amplifier to warm up to room temperature before turning it on. The heat generated by the tube elements can crack a cold glass housing.
- Replace the output tube(s) before the performance degrades or the tubes fail completely. Replace the tube(s) on a regular basis; at least once per year or as often as every 4 to 6 months if you play long and hard every day.
- Always have the bias checked after replacing the output tubes (unless the amplifier is equipped with "self-biasing circuitry"). This should be done ONLY at a qualified service center. Improper biasing could result in the tubes running too hot, which greatly reduces the life of the tubes – or too cold, which results in distorted sound regardless of level settings. Do not play the amplifier if it exhibits these symptoms – get the bias checked/adjusted immediately to prevent tube failure and/or other damage.
- If the locating notch on the base of the power tube breaks off, replace the tube. This significantly reduces the risk of damaging the amplifier by incorrectly inserting the tube.
- Protect the amplifier from dust and moisture. If liquid gets into the amplifier proper, or if the amplifier is dropped or otherwise mechanically abused, have it checked out at an authorized service center before using it.
- Proper maintenance and cleaning – in combination with routine checkups by an authorized service center – will ensure the best performance and longest life from the amplifier.

**CAUTION: Tube replacements should be performed only by qualified service personnel who are familiar with the dangers of hazardous voltages that are typically present in tube circuitry.**



### Changing the Tubes

Tubes wear out in direct proportion to how often and how hard you use the amplifier. Power tubes should be checked at least once a year – more frequently if you use the amplifier nearly every day. When power tubes wear out, the amplifier will begin to grow weak, lack punch, fade up and down, or lose highs and lows. Power tubes work together in a push/pull configuration and should be replaced at the same time with matched or balanced tubes. Your dealer can recommend the best replacement tubes for your amplifier.

Preamp tubes aren't worked as hard as power tubes and typically last longer. When a preamp tube wears out, the amplifier may squeal, get noisy, lose gain and sensitivity, or just quit working. A service center can determine which tube(s) may need replacing.

To get to the power tubes in the V-4B, the rear screen must be removed and the tube retainer(s) must be moved out of the way. **Qualified service persons** may follow these steps to change the tubes:

- Turn the amp off, unplug it and let it cool for at least 5 minutes.
- Remove the screws which hold the perforated metal screen to the rear of the cabinet.
- Set the perforated metal screen aside.
- Spread the tube retainer wings apart, grasp the tube at its top and gently work it out of its socket by rocking it slightly back and forth as you lift up on it.
- When inserting new output tubes, align the tab in the tube's plastic base with the slot in the socket and press the tube gently but firmly into place by pushing down on its top.
- Replace the perforated metal screen and screws.
- Power up the amplifier and let it sit for at least 20 minutes.
- An authorized service center can bias the amp.



## Troubleshooting

In the unlikely event that your V-4B should malfunction, take a few minutes to troubleshoot it before you call for service. You can save yourself time and money by doing it yourself, and often the cure for the problem is something quite simple. If you think the problem may be worn out tubes, see page 10–11 for symptoms of tube failure.

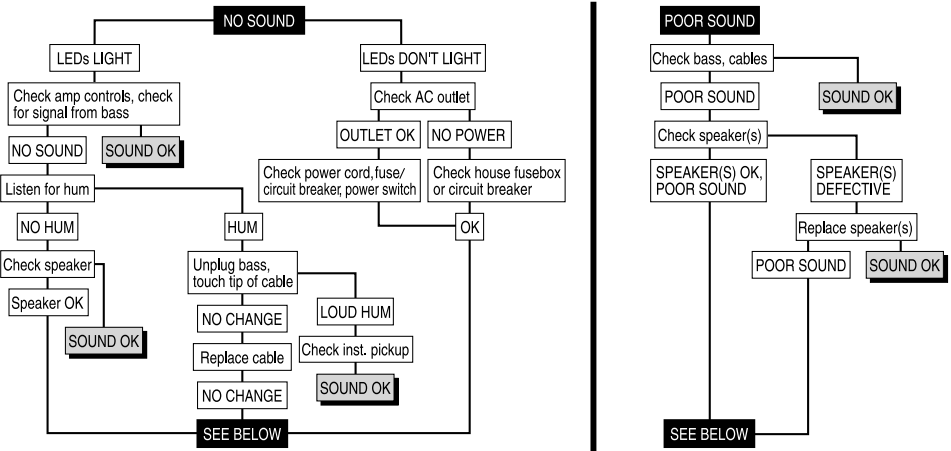

If the problem isn't covered above, or if the steps lead you here, then contact your Ampeg dealer for service information. Also, you should refer the amp for servicing if it gets dropped, has liquid spilled into it, or sustains damage to its power cord.

## Block Diagram

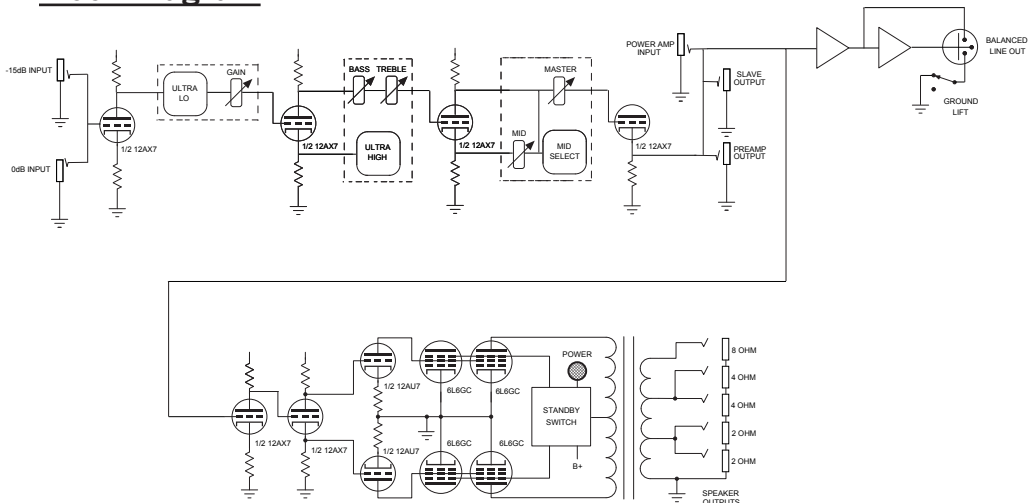



### V-4B TECHNICAL SPECIFICATIONS

Preamp Tube	2 x 12AX7
Driver Tube	1 x 12AX7, 1 x 12AU7
Power Amp Tube	4 x 6L6GC
Output Power Rating	100W @ 8% THD+N @1 kHz for 2, 4 or 8 $\Omega$ loads
Signal to Noise Ratio	80 dB @ 1 kHz (20 Hz–20 kHz, unweighted)
Maximum Gain	64 dB @ 1 kHz, tones centered -3 dB @ 14 Hz and 15 kHz
Tone Controls	Bass: +13/-12 dB @ 40 Hz Midrange: +11/-21 dB @ 220 Hz, 800 Hz, 3 kHz Treble: +14/-17 dB @ 4 kHz Ultra Lo: +2 dB @ 40 Hz, -11 dB @ 500 Hz Ultra Hi: +7 dB @ 8 kHz
Power Requirements	120VAC, ~60Hz, 200W (US) 220-240VAC, ~50-60Hz, 200W (EU) 100VAC, ~50-60Hz, 200W (JP)
Size (H x W x D)	10.8 in/275 mm (with feet) x 23.8 in/604 mm x 11.0 in/280 mm
Weight	41 lb/18.6 kg (approximately)

**The V-4B is covered with a durable fabric-backed vinyl material. Clean with a dry lint-free cloth. Never spray cleaning agents on the V-4B. Avoid abrasive cleansers which would damage the finish.**

*Ampeg continually develops new products and improves upon existing ones. For this reason, the specifications and information in this manual are subject to change without notice.*

*"Ampeg" is a registered trademark of LOUD Technologies Inc. All other brand names mentioned are trademarks or registered trademarks of their respective holders and are hereby acknowledged.*

### Service Information

If you are having a problem with your V-4B amplifier, you can go to our website ([www.amepg.com](http://www.amepg.com)) and click on Support for service information, or call Technical Support at 1-800-898-3211 Monday-Friday during normal business hours, Pacific Time, to receive assistance. If you are outside of the U.S., contact your local distributor for technical support and service.

# Ampeg

## V-4B

### Bass Guitar Amplifier



Owner's Manual