

14	15	16	MASTER
<input type="radio"/> HI PASS <input type="radio"/> CLIP GAIN MIN MAX HF -15 +15 HM FREQ 1K 2K 600 7K 500 15K HM GAIN -15 +15 LM FREQ 80 15 350 60 +1K 50 +3K LM GAIN -15 +15 LF -15 +15 FX SEL <input type="radio"/> 1 <input type="radio"/> 2	<input type="radio"/> HI PASS <input type="radio"/> CLIP GAIN MIN MAX HF -15 +15 HM FREQ 1K 2K 600 7K 500 15K HM GAIN -15 +15 LM FREQ 80 15 350 60 +1K 50 +3K LM GAIN -15 +15 LF -15 +15 FX SEL <input type="radio"/> 1 <input type="radio"/> 2	<input type="radio"/> HI PASS <input type="radio"/> CLIP GAIN MIN MAX HF -15 +15 HM FREQ 1K 2K 600 7K 500 15K HM GAIN -15 +15 LM FREQ 80 15 350 60 +1K 50 +3K LM GAIN -15 +15 LF -15 +15 FX SEL <input type="radio"/> 1 <input type="radio"/> 2	 hear TECHNOLOGIES <input type="checkbox"/> POWER <input type="checkbox"/> LED TALKBACK MIC ST AUX IN AUX-ST1 AUX-ST2 EFFECTS RTN FX1-ST1 FX2-ST1 FX1-ST2 FX2-ST2 mix back MASTER OUT ST1 ST2 1 2 3 4 5 6 7 8 9 10 11 12 METER & HP SEL <input type="checkbox"/> CLIP <input type="checkbox"/> ++ <input type="checkbox"/> -10 <input type="checkbox"/> SIG VOLUME <input type="radio"/> ST1 <input type="radio"/> ST2 <input type="radio"/> FX1/FX2 PHONES <input type="radio"/> 1/2 <input type="radio"/> 3/4 <input type="radio"/> 5/6 <input type="radio"/> 7/8 <input type="radio"/> 9/10 <input type="radio"/> 11/12
14	15	16	MASTER



hear
TECHNOLOGIES®

mix back™

user guide

ENGLISH

Danger

Exposure to extremely high noise levels may cause a permanent hearing loss. Individuals vary considerably to noise induced hearing loss but nearly everyone will lose some hearing if exposed to sufficiently intense noise for a sufficient time.

The U.S. Government's Occupational Safety and Health Administration (OSHA) has specified the following permissible noise level exposures:

DURATION PER DAY (HOURS)	8	6	4	3	2	1
SOUND LEVEL (dB)	90	93	95	97	100	103

According to OSHA, any exposure in the above permissible limits could result in some hearing loss. Ear plugs or protectors in the ear canal or over the ears must be worn when operating this amplification system in order to prevent a permanent hearing loss. If exposure in excess of the limits as put forth above, to insure against potentially harmful exposure to high sound pressure levels, it is recommended that all persons exposed to equipment capable of inducing high sound pressure levels, such as this amplification system, be protected by hearing protectors while this unit is in operation.

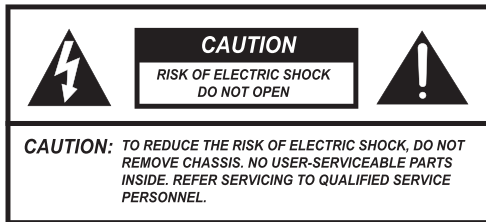

AVIS: RISQUE DE CHOC ELECTRIQUE-NE PAS OUVRIR.



THIS SYMBOL IS INTENDED TO ALERT THE USER TO THE PRESENCE OF NON-INSULATED "DANGEROUS VOLTAGE" WITHIN THE PRODUCT'S ENCLOSURE THAT MAY BE OF SUFFICIENT MAGNITUDE TO CONSTITUTE A RISK OF ELECTRIC SHOCK TO PERSONS.



THIS SYMBOL IS INTENDED TO ALERT THE USER TO THE PRESENCE OF IMPORTANT OPERATING AND MAINTENANCE (SERVICING) INSTRUCTIONS IN THE LITERATURE ACCOMPANYING THE UNIT.

IMPORTANT SAFETY INSTRUCTIONS

1. Read all safety and operating instructions before using this product.
2. All safety and operating instructions should be kept for future reference.
3. Read and understand all warnings listed on the operating instructions.
4. Follow all operating instructions to operate this product.
5. This product should not be used near water, i.e. bathtub, sink, swimming pool, wet basement, etc.

6. Only use dry cloth to clean this product.
7. Do not block any ventilation openings. It should not be placed flat against a wall or placed in a built-in enclosure that will impede the flow of cooling air.
8. Do not install this product near any heat sources; such as, radiators, heat registers, stove or other apparatus (including heat producing amplifiers) that produce heat.
9. Do not defeat the safety purpose of the polarized or grounding-type plug. A polarized plug has two blades with one wider than the other. A grounding-type plug has two blades and a third grounding prong. The wide blade or the third prong are provided for your safety. If the provided plug does not fit into your outlet, consult an electrician for replacement of the obsolete outlet.
10. Protect the power cord being walked on or pinched, particularly at plugs, convenience receptacles and the point where they exit from the apparatus. Do not break the ground pin of the power supply cord.
11. Only use attachments specified by the manufacturer.
12. Use only with the cart, stand, tripod, bracket, or table specified by the manufacturer or sold with the apparatus. When a cart is used, use caution when moving cart/apparatus combination to avoid injury from tip-over.
13. Unplug this apparatus during lightning storms or when unused for long periods of time.
14. Care should be taken so that objects do not fall and liquids are not spilled into the unit through the ventilation ports or any other openings.
15. Refer all servicing to qualified service personnel. Servicing is required when the apparatus has been damaged in any way; such as, power-supply cord or plug is damaged, liquid has been spilled or objects have fallen into the apparatus, the apparatus has been exposed to rain or moisture, does not operate normally, or has been dropped.
16. **WARNING:** To reduce the risk of fire or electric shock, do not expose this apparatus to rain or moisture.
17. The apparatus shall be connected to a mains socket outlet with a protective earthing connection.
18. Mains plug is used as the disconnect device. It shall remain readily operable and should not be obstructed during intended use.
19. **WARNING:** To prevent injury, this apparatus must be securely attached to a rack in accordance with the installation instructions.
20. Detailed installation instruction in user manual.

FRENCH

Danger

L'exposition a des niveaux eleves de bruit peut provoquer une perte permanente de l'audition. Chaque organisme humain reagit differemment quant a la perte de l'audition, mais quasiment tout le monde subit une diminution de l'acuite auditive lors d'une exposition suffisamment longue au bruit intense. Les autorites competentes en reglementation de bruit ont defini les expositions tolerees aux niveaux de bruits:

DURE EN HEURES PAR JOUR	8	6	4	3	2	1
NIVEAU SONORE CONTINU EN dB	90	93	95	97	100	103

Selon les autorites, toute exposition dans les limites citees ci-dessus, peuvent provoquer certaines pertes d'audition. Des bouchons ou protections dans l'appareil auditif ou sur l'oreille doivent etre portes lors de l'utilisation de ce systeme d'amplification afin de prevenir le risque de perte permanente de l'audition. Dans le cas d'expositions superieures aux limites precitees il est recommande, afin de se premunir contre les expositions aux pressions acoustiques elevees potentiellement dangeereuses, aux personnes exposees aux equipements capables de delivrer de telles puissances, tels ce systeme d'amplification en fonctionnement, de proteger l'appareil auditif.



CE SYMBOLE A POUR BUT D'AVERTIR L'UTILISATEUR DE LA PRESENCE DE VOLTAGE DANGEREUX NON-ISOLE A L'INTERIEUR DE CE PRODUIT QUI PEUT ETRE DE PUISSANCE SUFFISAMMENT IMPORTANTE POUR PROVOQUER UN CHOC ELECTRIQUE AUX PERSONNES.



CE SYMBOLE A POUR BUT D'AVERTIR L'UTILISATEUR DE LA PRESENCE D'INSTRUCTIONS D'UTILISATION ET DE MAINTENANCE DANS LES DOCUMENTS FOURNIS AVEC CE PRODUIT.

IMPORTANTES INSTRUCTIONS DE SECURITE

1. Lire avec attention toutes les recommandations et precautions d'emploi avant d'utiliser ce produit.
2. Toutes les recommandations et precautions d'emploi doivent etre conservees afin de pouvoir s'y reporter si necessaire.
3. Lire et comprendre tous les avertissements enumerés dans les precautions d'emploi.
4. Suivre toutes les precautions d'emploi pour utiliser ce produit.
5. Ce produit ne doit pas etre utilise pres d'eau, comme par exemple baignoires, eviers, piscine, sous-sol humides...etc.
6. Utiliser exclusivement un chiffon sec pour nettoyer ce produit.
7. Ne bloquer aucune ouverture de ventilation. Ne pas placer le produit tout contre un mur ou dans une enceinte fermée, cela generait le flux d'air necessaire au refroidissement.
8. Ne pas placer le produit pres de toute source de chaleur telle que radiateurs, arrivees d'air chaud, fourneaux ou autres appareils generant de la chaleur (incluant les amplificateurs producteurs de chaleur).
9. Ne pas negliger la securite que procure un branchement polarise ou avec raccordement a la terre. Un branchement polarise comprend deux fiches dont l'une est plus large que l'autre. Un branchement a la terre comprend deux fiches plus une troisieme reliee a la terre. Si la fiche secteur fournie ne s'insert pas dans votre prise de courant. consulter un electricien afin de remplacer votre prise obsolète.
10. Protéger le cordon d'alimentation de tout ecrasement ou pincement, particulierement au niveau des fiches, des receptacles utilises et a l'endroit de sortie de l'appareil. Ne pas casser la fiche de terre du cordon d'alimentation.
11. Utiliser uniquement les accessoires specifies par le constructeur.
12. Utiliser uniquement avec le chariot de transport, le support, le tripied, la console ou la table specifies par le constructeur ou vendus avec l'appareil. Lors de l'utilisation d'un chariot, bouger avec precaution l'ensemble chariot/appareil afin d'éviter les dommages d'un renversement.
13. Débrancher cet appareil lors d'orages ou s'il n'est pas utilise pendant une longue periode.
14. Des precautions doivent etre prises afin qu'aucun objet ne tombe et qu'aucun liquide ne se repande a l'interieur de l'appareil par les orifices de ventilation ou n'importe quelle autre ouverture.
15. Pour toutes interventions techniques s'adresser a un technicien qualifié. L'intervention technique est necessaire lorsque l'appareil a été endommagé de n'importe quelle façon, comme par exemple si le cordon secteur ou sa fiche sont detériorés, si du liquide a coulé ou si des objets sont tombés a l'interieur de l'appareil, si l'appareil a été expose a la pluie ou a l'humidité, s'il ne fonctionne pas normalement ou s'il est tombé.
16. ATTENTION: Pour réduire le risque d'incendie ou de choc électrique ne pas exposer l'appareil a la pluie ou a l'humidité.
17. L'appareil sera relie a un socle principal d'électricité muni d'une mise a terre protectrice.
18. Le cordon d'alimentation est utilisée comme dispositif de débranchement. Il restera aisément fonctionnelle et ne devrait pas etre obstrué pendant l'utilisation prévue.
19. AVERTISSEMENT Pour raison de securite, cet appareil doit etre solidement fixé a un rack selon les instructions d'installation.
20. Instruction d'installation détaillée a l'interieur du manuel d'utilisateur.



CONTENTS

01	safety instructions
03	table of contents
04	introduction to personal monitor mixing
05	general description
07	detail diagrams
07	input channel front panel detail
07	input channel rear rear panel detail
08	master section front panel detail
08	master section rear rear panel detail
09	mix back talkback remote control detail
10	setup and use
10	installation
10	connecting
10	setting gain
10	using talkback
11	using for PA, hear back, and recording
11	studio cue mixing
12	specifications
13	block diagram
15	hook-up diagrams
15	studio
16	24 “more me” channels using two mix backs
17	live PA, hear back, and recording
18	multi-zone background/foreground music with paging
19	conventional monitor mixing
20	connectors
21	mix back system accessories
22	other hear technologies products
23	glossary of terms
24	limited warranty
25	notes

If you need further assistance, feel free to contact **Hear Technologies** technical support by phone at 1-256-922-1200 or visit our web site at <http://www.HearTechnologies.com>.



Forget everything you've ever learned about monitor mixing!

WHY?

Better Control of Your Mix

In-ear monitors (IEM) and personal monitor mixing provide several benefits above conventional monitoring:

- No feedback – now you can EQ the vocal mic
- Greatly reduced or eliminated stage volume (*yea!*)
- Virtual elimination of room acoustic coloration on stage (*ever played in a gymnasium?*)
- Elimination of sign language between stage and sound engineer (*no more semaphores!*)
- Most importantly, you get to Control Your Mix®

Mix Back and Hear Back Make It Easy

With some monitor systems, it is possible for the talent to create his or her own mix. However, there are two drawbacks of a musician mixing all of the individual mixes:

- a. They don't know what they sound like in the audience because their ears are plugged up with in-ear monitors. *Do you care what you sound like to the audience?*
- b. Players need to be playing, not mixing

With Hear Back, it's as simple as turning up the "perfect mix" (front of house, recording studio two mix, etc.) and adjusting your "more me" input(s). Simply turn the knobs and smile.

EXAMPLE: Your star vocalist should not waste time mastering an extensive system of switches, dials, displays and cables resembling the cockpit of a 747. They just need the "perfect mix" (channels 1 & 2) and their "more me" input. Now time and energy is where it should be – performing!

We recommend you connect the "perfect mix" from the FOH console or studio "two mix" to the Mix Back stereo aux input.

TIP *When using in-ear monitors the talent loses their psycho-acoustic space because stage reflections are lost. To cure this, create a stereo mix (as perceived on stage) to help restore the natural feel. When performing live, the "perfect mix" lets you hear what the audience hears.*

TIP *Connect an ambient microphone to a Mix Back input (located near the band front line) so the talent can hear the audience. Locating the mic far away adds an unnatural delay. Sound travels at roughly one foot per millisecond, so a mic placed 100 feet into the audience has a 100 mSec delay. It is often necessary to add a limiter to the ambient mic channel to prevent excessive ambient signal into the monitor mix.*



mix back™

*Thank you for purchasing the Hear Technologies
Mix Back!*

MIX BACK MIXER DESCRIPTION

Mix Back is a flexible 16 x 12 x 2 x 2 monitor mixer. Featuring two stereo and twelve mono busses, it's a perfect companion for Hear Back, as well as conventional monitoring systems and wireless in-ear systems. Mix Back is equally at home as a stand-alone mains and monitor mixer.

Each channel features a signal/clip LED, Gain control, 100 Hz hi-pass filter, four-band EQ, switch-selectable dual effects sends, two stereo volume and pan controls, and twelve mono volume controls.

The master section features AFL (After Fade Listen) meter/headphone selection, stereo auxiliary input, and two effects returns. A built-in talkback mic preamp permits talking to any or all of the master outputs as well as a balanced output using the optional sixteen-button talkback remote.

The sixteen master outputs are available as balanced TRS analog, ADAT, and HearBus.

ADVANTAGES / FEATURES

- Independent Monitor control
- Frees front of house and recording console I/O for other duties
- High quality Mic preamplifiers
- Four band EQ with quasi-parametric sweepable mid controls
- Very low distortion
- Built-in talkback feature controllable only with optional remote control
- Buss inputs permit linking mixers together
- Stereo Aux input assignable to ST1 and ST2
- Dual effects send/return
- Switch-selectable AFL meter/headphone monitoring
- Analog, ADAT, and HearBus outputs
- Glow-in-the-dark knob pointers and silkscreen
- UV LED Lamp included
- Rack Mountable (11RU)

FC FCC Statement

Note: This equipment has been tested and found to comply with the limits for a Class B digital device, pursuant to part 15 of the FCC Rules. These limits are designed to provide reasonable protection against harmful interference in a residential installation. This equipment generates, uses and can radiate radio frequency energy and, if not installed and used in accordance with the instructions, may cause harmful interference to radio communications. However, there is no guarantee that interference will not occur in a particular installation. If this equipment does cause harmful interference to radio or television reception, which can be determined by turning the equipment off and on, the user is encouraged to try to correct the interference by one or more of the following measures:

- Reorient or relocate the receiving antenna.
- Increase the separation between the equipment and receiver.
- Connect the equipment into an outlet on a circuit different from that to which the receiver is connected.
- Consult the dealer or an experienced radio/TV technician for help.



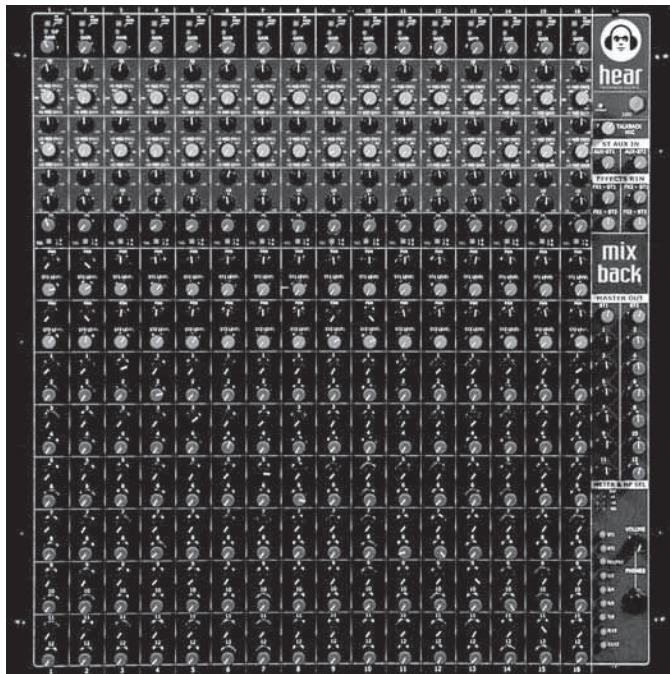

mix back mixer



UV LED lamp



mix back remote
(optional)

APPLICATIONS

- Monitor Mixer
- Front of House Mixer
- Recording Studio Cue Mixer
- Post Production Mixer
- Multi-Zone Distributed Audio with Paging

MIX BACK USED AS A STAND-ALONE LIVE SYSTEM

- Stereo FOH mix – connected via stereo analog outputs
- Hear Back – connected via sixteen channel HearBus outputs
- Recording – connected via the sixteen channel ADAT outputs

When used in conjunction with Hear Back, the talent has total control over cue or personal monitor mixes. The Mix Back provides control for effects, EQ, and a stereo baseline “perfect mix”. Combine all that with the talkback feature and you have a winning combination, sure to bring smiles to the talent!

The built-in talkback function permits the band director to talk specifically to each talent through the individual “more me” outputs, as well as both stereo busses.

The optional talkback remote may be connected up to 500 feet from the Mixer using standard CAT5e cable. The talkback (remote COM) balanced output acts as an intercom for communicating with the front of house engineer or to the talent when used in a studio. The remote COM button also activates a relay for lighting beacons or virtually any function needing a set of dry contacts.

EACH INPUT CHANNEL FEATURES

- High quality Mic/Line inputs
- Passive XLR split with Pin 1 lift
- Phantom Mic power switch
- Channel insert
- Signal/Clip LED indicator
- 100 Hz high-pass filter
- Gain control
- Four-band EQ with dual sweepable mids
- Two stereo level and pan controls (ST1 and ST2)
- Twelve mono level controls (1-12)
- Dual switch-selectable effects sends

- 1 Hi-Pass filter:** Use to eliminate low frequency stage rumble and wind noise in microphones. Use whenever possible to prevent excessive low energy build up in the mixer busses.
 - 2 Signal/Clip LED:** This indicator is post-EQ, pre-volume.
 - 3 Preamp Gain Control**
 - 4 HF (Hi Frequency):** 10 KHz shelving EQ, +/- 15 dB gain cut/boost
 - 5 HM (Hi Mid) Frequency:** Adjustable from 500 Hz to 15,000 Hz
 - 6 HM Gain control:** +/- 15 dB cut/boost
 - 7 LM (Lo Mid) Frequency:** Adjustable from 50 Hz to 3,000 Hz
 - 8 LM Gain control:** +/- 15 dB cut/boost
 - 9 LF (Lo Frequency):** 100 Hz shelving, +/- 15 dB cut/boost
- TIP** It is wise to cut undesirable frequencies rather than boost desired frequencies because it causes less ringing associated with analog EQ.
- 10 FX Level:** Adjusts the effects send level
 - 11 FX Select:** Selects effects send 1 or 2
 - 12 ST1 (Stereo 1) Pan:** Use to pan input to the desired stereo position
 - 13 ST1 (Stereo 1) Level:** Adjusts level to the Stereo 1 master buss
 - 14 ST2 (Stereo 2) Pan:** Use to pan input to the desired stereo position
 - 15 ST2 (Stereo 2) Level:** Adjusts level to the Stereo 2 master buss
 - 16 Mono level 1-12:** Adjusts level to mono master outputs 1 thru 12

front panel

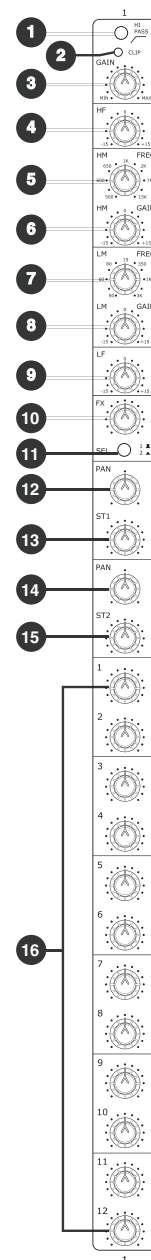

rear panel

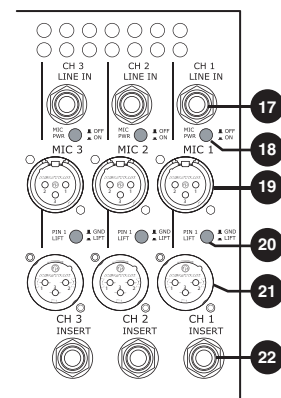

- 17 Line Input:** TRS Balanced
- 18 Phantom Mic Power Switch:** +18 VDC (powers most condensers)
Note: Turn off the Mic power switch if you use FOH console or recording console phantom power.
- 19 Mic Input:** XLR (Pin 2 +)
- 20 Pin 1 Ground Lift:** For Output XLR
- 21 Passive Split XLR Output**
- 22 Channel Insert:**
Tip = Send
Ring = Return
Sleeve = Ground (SHIELD)



MASTER SECTION FEATURES

- Two stereo and twelve mono TRS balanced analog outputs
- Sixteen channels of ADAT and HearBus output
- Switch-selectable AFL meter/headphone monitoring
- Two stereo TRS balanced effects returns assignable to both stereo masters
- Buss inputs permit linking mixers together
- Stereo Aux return assignable to both stereo busses – for FOH or studio “two mix”
- Talkback is assignable to ST1 and ST2, mono 1-12, and COM outputs
- Talkback relay contacts activate when the talkback remote COM switch is pressed
- Optional talkback remote connects using a standard CAT5e cable

front panel

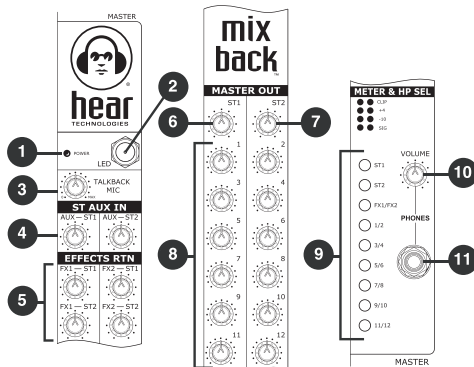

- 1 Power LED Indicator**
- 2 UV LED Lamp BNC connector**
⚠ CAUTION: Use Only Hear Technologies UV LED Lamp. This connector not intended for other style lamps.
- 3 Talkback level control**
- 4 Stereo Auxiliary input level controls:**
To Stereo 1 and to Stereo 2 Masters
- 5 Effects 1 to ST1/ST2 and Effects 2 to ST1/ST2 level controls:** Adjust the amount of each effects return into Stereo 1 and Stereo 2 master busses
- 6 Stereo 1 L/R Master level control**
- 7 Stereo 2 L/R Master level control**
- 8 Mono 1 thru 12 Master level controls:**
Note: All Master level controls control the analog, HearBus, and ADAT outputs simultaneously.
- 9 Meter/Headphone switches:** AFL (After Fade Listen) for all masters including effect sends. Push a switch to select the relative VU meter and headphone amplifier.
- 10 Headphone level control:** Follows AFL switches and adjusts level in headphones.
- 11 Headphone Output**

- 12 Talkback Mic Input: XLR**
- 13 Talkback Output: TRS Balanced**
- 14 Stereo Aux Inputs: TRS Balanced L/R**
- 15 Talkback Relay:** One-Amp contacts for light beacon, Control Room monitor dimming, or logic contacts.
NOTE: Not for inductive loads.
- 16 Talkback Remote Control Input:** Connects up to 500 feet away using a standard CAT5e cable which provides power and communications.
- 17 ADAT Optical Outputs (2):** Assigned as ST1 L/R, mono 1-6, and ST2 L/R, mono 7-12

- 18 HearBus Outputs (2):** Assigned like ADAT outputs

RJ45 Pin Outs:

Pin	Function	Pin	Function
1	Digital Audio+	5	-18 VDC
2	Digital Audio-	6	Ground
3	Ground	7	+18 VDC
4	+18 VDC	8	-18 VDC

- 19 ADAT/HearBus Clock Frequency Selector:** 44.1 KHz or 48 KHz
- 20 Buss Inputs (20):** ST1 L/R, ST2 L/R, mono 1-12, and FX1/FX2 stereo returns. Used for linking mixers together.
- 21 Analog Outputs (18):** ST1 L/R, ST2 L/R, mono 1-12, FX1 and FX2 sends (balanced)
- 22 Universal AC Power Supply Input:** 100-240 VAC~, 50/60 Hz
- 23 AC Power Switch**

rear panel

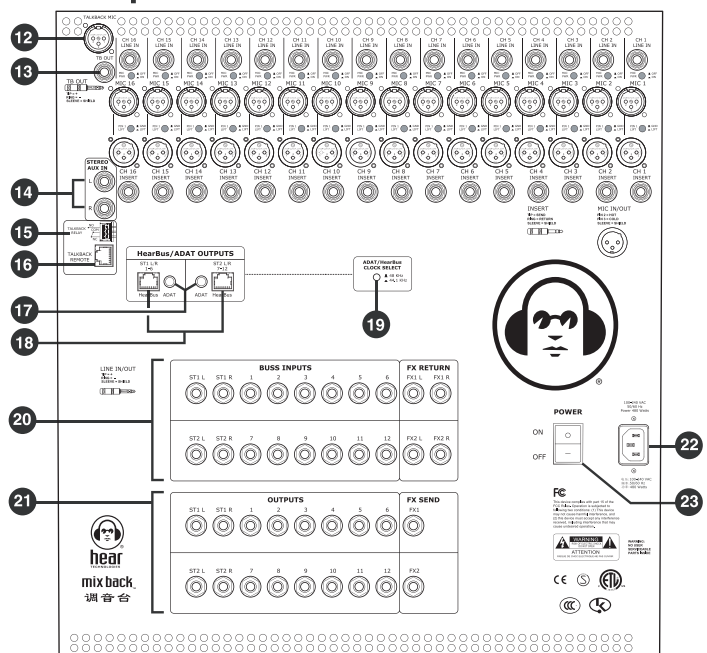

TALKBACK REMOTE CONTROL *(Optional)*

- 1 **Remote Output:** The Mix Back Remote is connected to the Mix Back using standard CAT5e cable. (wired 1 to 1)
- 2 **Switches 1-12:** Routes the talkback microphone to the corresponding Mix Back master sections. Very useful for talking to a particular “more me” output. Talkback is useful for live and studio personal cue.
- 3 **ST1/ST2:** When selecting ST1 and/or ST2 switches, one can talk to everyone listening to those corresponding stereo mixes.
- 4 **COM:** The COM button turns on the talkback balanced output connector on the rear panel and closes the talkback relay (for light beacons, dimming module for control rooms, the Talk Back 600 MV logic input, etc.).
- 5 **ALL:** The ALL switch permits the talkback microphone to route to all outputs at the same time. This can be thought of as a broadcast to everyone connected to the Mix Back outputs.

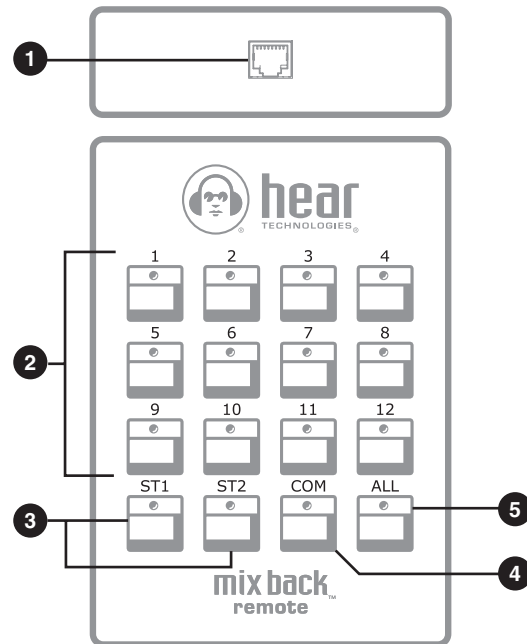

Remote Control RJ45 Pin Outs:

Pin	Function
1	Digital +
2	Digital -
3	Ground
4	+18 VDC
5	No Connect
6	Ground
7	+18 VDC
8	No Connect

Relay Output:

- 1 = Normally Open (Top Pin)
- 2 = Common (Center Pin)
- 3 = Normally Closed (Bottom Pin)

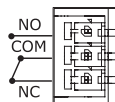

SETTING UP MIX BACK FOR THE FIRST TIME

INSTALLATION

⚠ CAUTION: Before you begin, make sure your mixer is disconnected from the power source and all level controls are turned off.

Use an EIA 19" (48.26 cm) equipment rack or cabinet.

CONNECTING

1. Connect all inputs and label channels.
2. Connect channel XLR outputs to the FOH mixer. When using a line input it may be necessary to lift pin 1 on that channel to prevent ground loops.
3. Set all gain pots to 12 o'clock.
4. Set all EQ gain settings to "0".
5. Turn off all input level controls.



SETTING GAIN

Set the gain of the input channels as follows:

1. Input the maximum signal level (microphone, instrument signal, etc.). Rotate gain control clockwise until the signal/clip light just turns red, then back off the gain until the clip light goes off. You may have to reduce the gain if you boost tone settings.

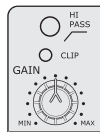

NOTE: mixing consoles have the lowest noise at the input section. Always maximize gain and volume level at the input channels then adjust the master levels to the desired output level for lowest noise.

2. Repeat step 1 for each channel. With all inputs adjusted and with active input signals, proceed to set the appropriate level at the master level controls. Optimum is normally at 12 o'clock.

3. If effects are used, select the desired send (1 or 2) to route the channel signal to the desired effects device. Simply select the FX1 or FX 2 switch (below the FX send control) and then adjust for optimum signal level on the effects input display and the AFL meter.



- a. Repeat for each channel.
- b. Adjust the master FX1 to ST1/ST2 and FX2 to ST1/ST2 as desired to obtain the level of effects in each of the stereo masters.

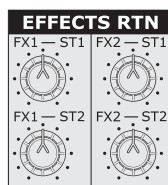

USING TALKBACK

1. Talkback remote connection:

Connect the optional remote control to the Mix Back using standard CAT5e cable. The connection will work up to 500 feet or 152.4 meters.

⚠ CAUTION: NEVER PLUG THE MIX BACK REMOTE INTO THE HEARBUS OUTPUT OR A HEAR BACK HUB MIXER OUTPUT AS DAMAGE CAN OCCUR DUE TO OVER VOLTAGE!

2. Using talkback with output channels assigned on the Mix Back:

a. Label the remote to match master output channels such as drummer, vocals, etc.

b. Connect a dynamic microphone to the talkback microphone input.

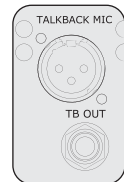

c. Now the director/engineer can speak to any dedicated "more me" output independently. The balanced talkback output becomes active when pressing the COM switch on the remote. This is very useful for communicating with a sound person, or anyone off the stage that has the capabilities to hear the talkback via the balanced line output. *Examples:* choir rooms, video rooms, recording studios, etc.

d. Use the talkback (COM) relay to control light beacons or logic level controls using the relay contacts. The relay is a single pole-single throw relay. Pin outs are NO, Com, NC.

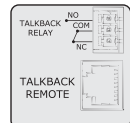

Example: Assume you have two Hear Back Hubs, one for vocals and one for the band. Let's also assume the Mix Back Stereo 1 outputs are connected to the "Vocal Hub" channels 1&2 stereo mix, and the Mix Back ST2 (Stereo 2) outputs are connected in the same manner to channels 1&2 of the "band hub". You can now use the ST1 or ST2 switches on the remote to address just the band or just the vocalist.

e. The talkback ALL switch routes the talkback microphone to all outputs.

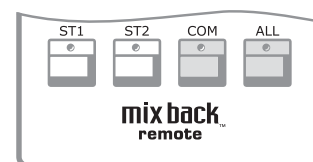

USING MIX BACK FOR PA, HEAR BACK, AND RECORDING

1. Using the Mix Back, Hear Back and ADAT equipped recorders at the same time (*see the hook-up diagram on page 17*):
 - a. Connect the Mix Back HearBus outputs to Hear Back Hub HearBus inputs.
 - b. Connect Stereo Master 1 analog outputs to the PA system.
 - c. Connect Mix Back ADAT optical outputs to a digital recorder with ADAT inputs.
 - d. Duplicate the stereo (“Perfect Mix”) on both Stereo 1 (PA) and Stereo 2 (Hear Back) as the base line mix for the Hear Back system(s). This permits the performers to hear the equivalent FOH mix as in the PA system.
 - e. Adjust the Mix Back mono channel (“more me”) outputs (mono 1-12) and send them to the appropriate “more me” Hear Back Hub inputs. Example: if Channel 1 of the Mix Back is the guitar player, then adjust mono volume 1 to obtain the appropriate level, turn all other Mono volumes off. Doing this sends just the guitar to channel three on the Hear Back Hub.

NOTE: Since Mix Back channels 1&2 are the “stereo mix/perfect mix” and are sent to the HUB channels 1&2 then mono channels are skewed by two channels, i.e. Mix Back channel one is channel three on the hub, Mix Back channel two is channel four on the hub, and so on.

IMPORTANT: When using in-ear monitors you need a baseline stereo mix to verify what the audience hears. Always assign the stereo mix so it appears on every Hear Back Mixer stereo knob (Channels 1&2). A stereo mix is critical since ambience and physco-acoustics are absent with in-ears. (Hey – in-ears are earplugs!)

If you are sending the perfect mix from a FOH console, then plug that into the left/right Aux inputs and assign them to the Hear Back output channels ST1 and ST2.

NOTE: Reverse the left and right channels so you have the correct stereo image on the stage. You may feel a little strange if what you hear is a mirror image of what you see, i.e. the guitar player is physically on your left, but you hear him/her in your right ear (see physco-acoustics in the glossary).

STUDIO CUE MIXING USING MIX BACK AND HEAR BACK

1. Connect the inputs to the Mix Back so as to set up an independent Cue Mix. Use the passive splits to connect to your studio preamplifiers.
2. Talkback remote connection:

Connect the remote control to the Mix Back using standard CAT5e cable. The connection will work up to 500 feet or 152.4 meters.

⚠ CAUTION: NEVER PLUG THE MIX BACK REMOTE INTO A HEARBUS OR HEAR BACK MIXER CONNECTION BECAUSE AN OVER VOLTAGE DAMAGE CAN OCCUR!
3. Using the talkback after channels have been assigned on the Mix Back/Hear Back:
 - a. Label the Mix Back remote to correspond to the Hear Back channel assignments.
 - b. Now you have the option to speak only to the drummer – assuming only his/her “more me” is turned up. This applies to all “more me” channels.
 - c. The talkback feature has a balanced output that becomes active when pressing the COM switch on the remote. Use the talkback output as a slate function if desired. Simply connect the balanced talkback out to your recording device. The COM switch also energizes the intercom relay.
 - d. The ALL (broadcast) switch routes the talkback mic to all outputs.

MIX BACK SPECIFICATIONS

Passive Microphone Split (Each Channel)	
Mic In to Mic Out:	Passive
Mic Power:	+18 VDC
Pin 1 Lift:	Output XLR
Mic Input to Insert Output	
<i>Conditions: +14 dBu input, Gain full CCW, 150 Ω, Balanced</i>	
Frequency Response:	20 Hz to 20 KHz, +/- 0.05 dBu 10 Hz to 120 KHz, +/- 0.3 dBu
THD+N:	0.002%, 22 Hz to 22 KHz, unweighted
IMD:	0.003%
EIN:	-121 dBu, 150 Ω Source, -40 dBu input
Mic Pre to Master Output	
<i>Conditions: 0 dBu input, Gain full CCW, 150 Ω, Balanced</i>	
Frequency Response:	20 Hz to 20 KHz, +/- 0.5 dBu
THD+N:	0.004%, 22 Hz to 22 KHz, unweighted
IMD:	0.004%
Maximum Gain:	60 dBu, EQ Flat
Line Inputs to Insert Outputs	
<i>Conditions: +18 dBu input, Gain full CCW, 150 Ω, Balanced</i>	
Frequency Response:	20 Hz to 20 KHz, +/- 0.3 dBu
THD+N:	0.005%, 22 Hz to 22 KHz, unweighted
IMD:	0.005%
Input Impedance:	10K Ω, balanced
Attenuation:	18 dB
Channel Equalization	
Hi Frequency:	10 KHz shelving, +/- 15 dB
Hi Mid Frequency:	500 Hz to 15 KHz, +/- 15 dB
Lo Mid Frequency:	50 Hz to 3 KHz, +/- 15 dB
Lo Frequency:	100 Hz shelving, +/- 15 dB
Hi Pass Filter:	100 Hz, 3 pole, 18 dB/Octave
Buss Inputs to Master Outputs	
<i>Conditions: +4 dBu input, 150 Ohms, Balanced</i>	
Frequency Response:	20 Hz to 20 KHz, +/- 0.2 dBu
THD+N:	0.005%
IMD:	0.005%
Input Impedance:	10K Ω, balanced
Digital Output	
ADAT Output:	24 Bit, 44.1 KHz / 48 KHz Selectable
HearBus Output:	24 Bit, 44.1 KHz / 48 KHz Selectable
ADAT/HearBus 1	Master 1 L/R, Channels 1-6
ADAT/HearBus 2	Master 2 L/R, Channels 7-12
Analog Line Outputs	
Maximum Output Level:	+24 dBu, TRS Balanced
Output Impedance:	121 Ω, balanced

Note: 1) 0 dBu = 0.775 V rms

2) Talkback relay = 1 amp maximum

Talkback Mic Pre Amplifier	
<i>Conditions: -40 dBu input, 150 Ω, Balanced</i>	
Frequency Response:	20 Hz to 20 KHz, +/- 1.5 dBu
Gain:	Off to 50 dBu, variable
Line Output	121 Ω, TRS Balanced
Input Impedance:	1K Ω, balanced
THD:	0.05%
IMD:	0.09%
Remote Control:	1-12, ST1, ST2, COM, ALL
Remote Cable:	CAT5e, 500 ft. max, wired pin-to-pin
Effects (FX) Return	
<i>Conditions: +4 dBu input, 150 Ω, Balanced</i>	
Frequency Response:	20 Hz to 20 KHz, +/- 0.5 dBu
Gain, FX return to Master:	1 dB, Master at center
THD+N:	0.0025%, 20 Hz to 20 KHz
IMD:	0.0027%, 20 Hz to 20 KHz
Input Impedance:	10K Ω, balanced
Maximum Input Level:	+10 dBu, control centered
Stereo Aux Input	
<i>Conditions: +4 dBu input, 150 Ω, Balanced</i>	
Frequency Response:	20 Hz to 20 KHz, +/- 0.5 dBu
Gain:	Off to +6 dBu, Aux to Stereo Masters
THD+N:	0.0033%, 20 Hz to 20 KHz
IMD:	0.004%, 20 Hz to 20 KHz
Input Impedance:	10K Ω, balanced
Maximum Input Level:	+8 dBu
Power Supply (Universal)	
Input Voltage:	100 to 240 VAC~, 50-60 Hz
Input Current:	2 Amps
Maximum Continuous Input Power:	240 Watts
Fuse (Internal):	3.15 Amp
Inrush:	60 Amps, 2 mSec
Short Circuit Protection:	Yes
AC Input Connector:	IEC 320-C14, International
Agency Listing:	FCC class B, CISPR 22 class B, IEC 60950-1 safety, EN 61000-4-2, 4-4, 4-5
Physical	
Construction:	Steel Chassis / Steel Front Panel
Size (with 1" handles):	19.23" H x 19" W x 5.35" D (488mm H x 482.6mm W x 135mm D)
Unit Weight:	30.8 lbs (14 kg)
Mounting:	Standard rack mount, 11RU
Shipping Size:	10.55" H x 25.0" W x 24.53" D (268mm H x 635mm W x 623mm D)
Shipping Weight:	42.9 lb. (19.5 kg)

*Specifications and features subject to change without notice.

MIX BACK BLOCK DIAGRAM

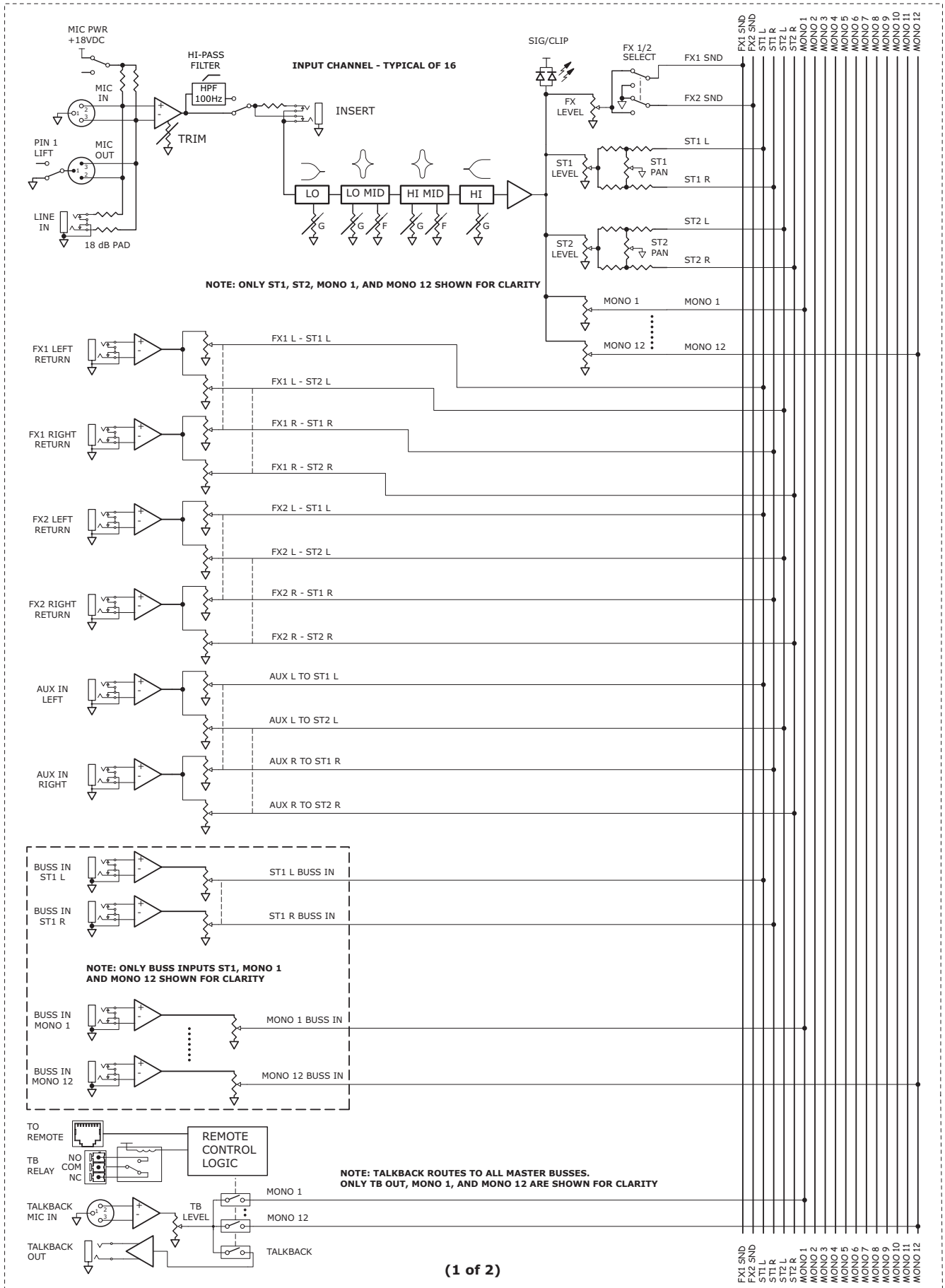

MIX BACK BLOCK DIAGRAM

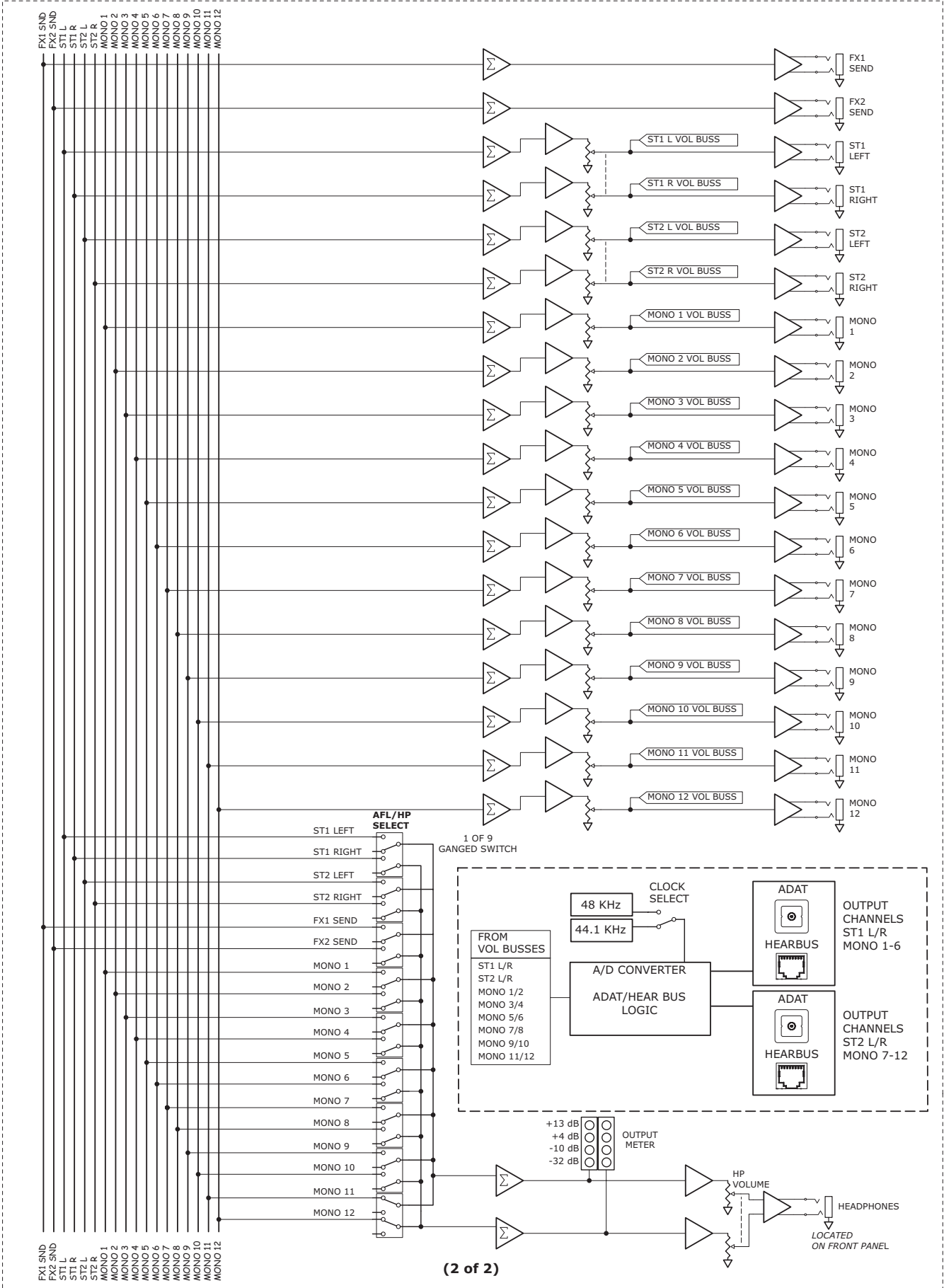

(2 of 2)

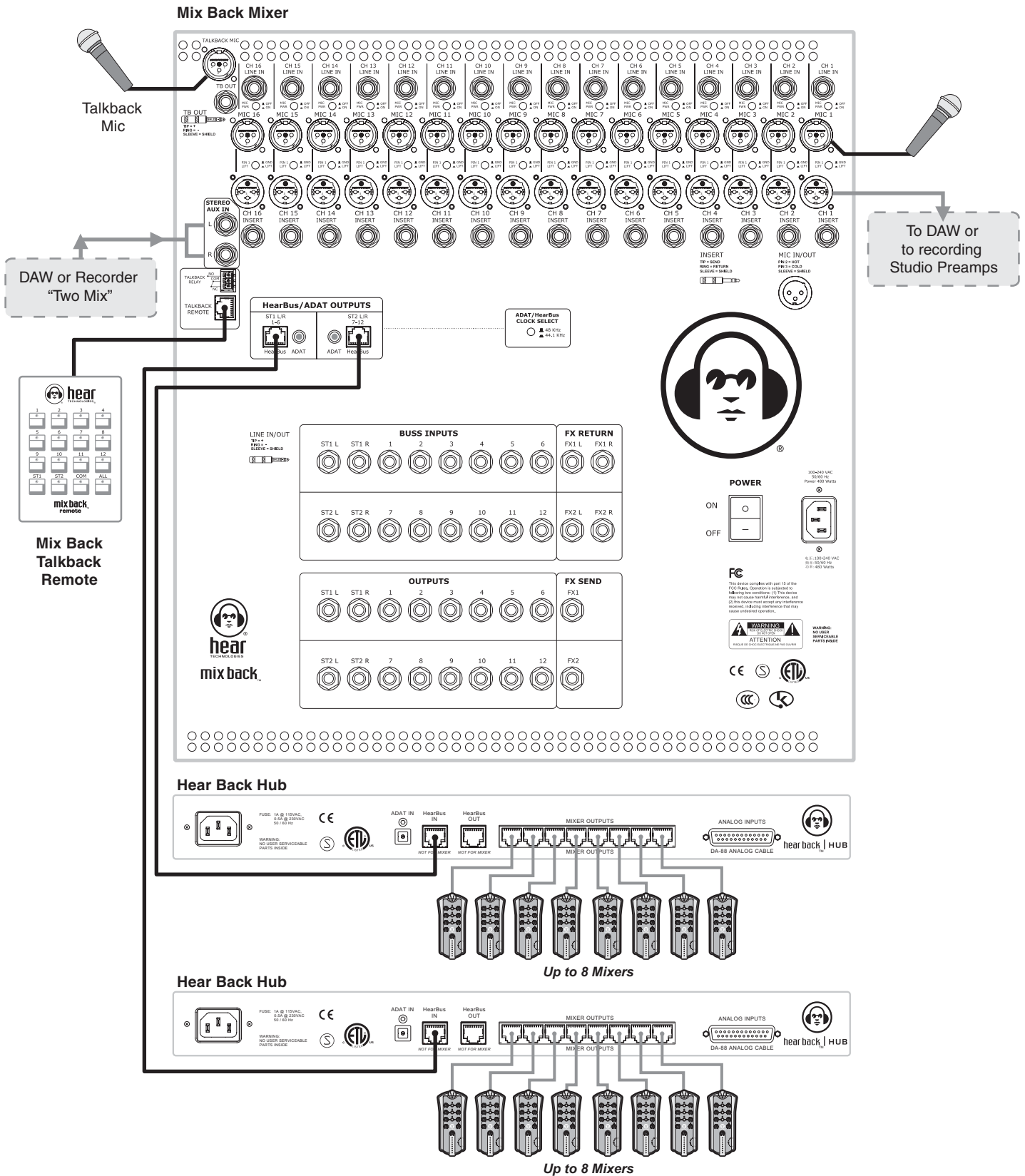

TWENTY-FOUR “MORE ME” CHANNELS USING TWO MIX BACKS AND FOUR HEAR BACK HUBS

HOOK-UP DIAGRAM

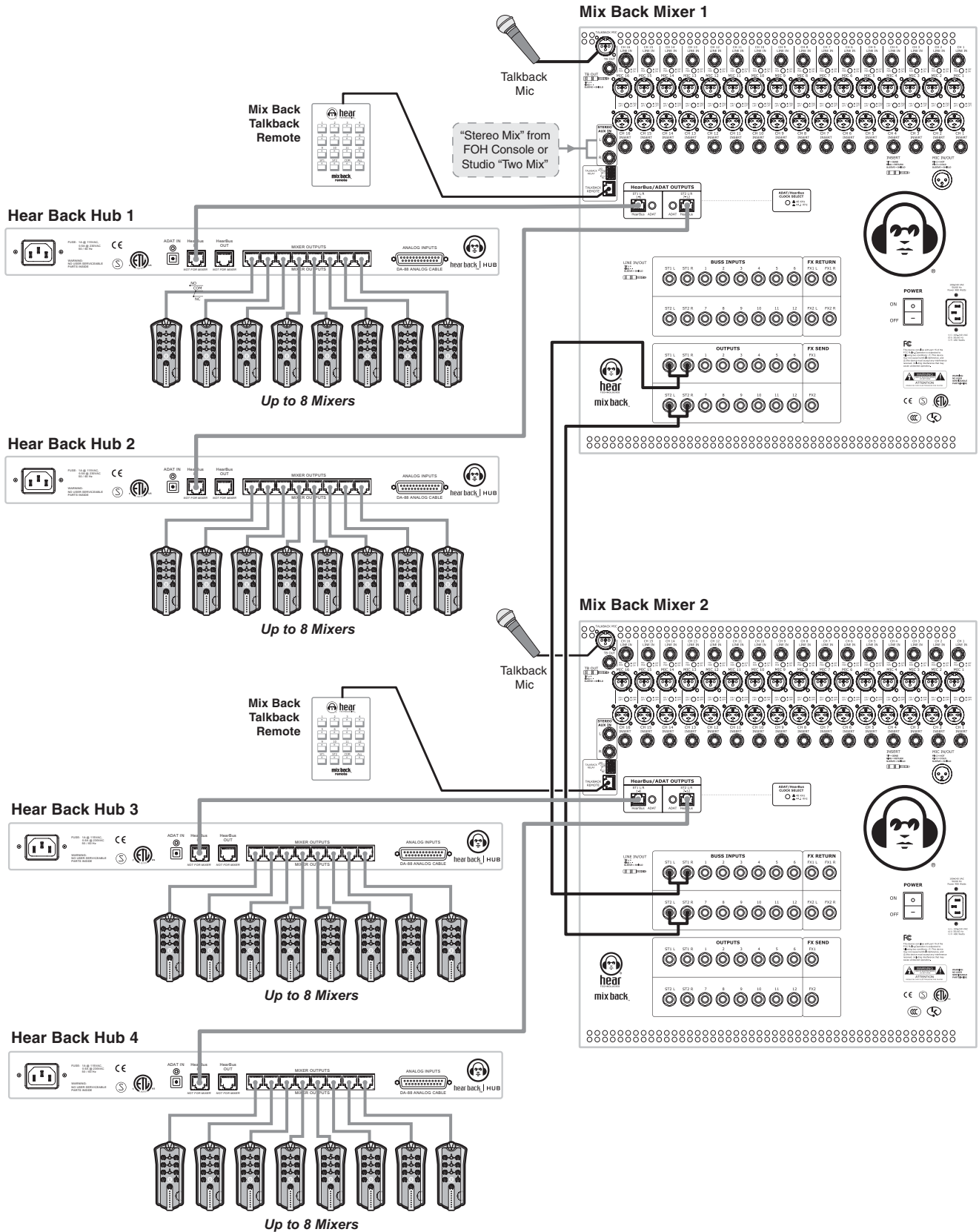

HOOK-UP DIAGRAM

LIVE PA, HEAR BACK, AND RECORDING

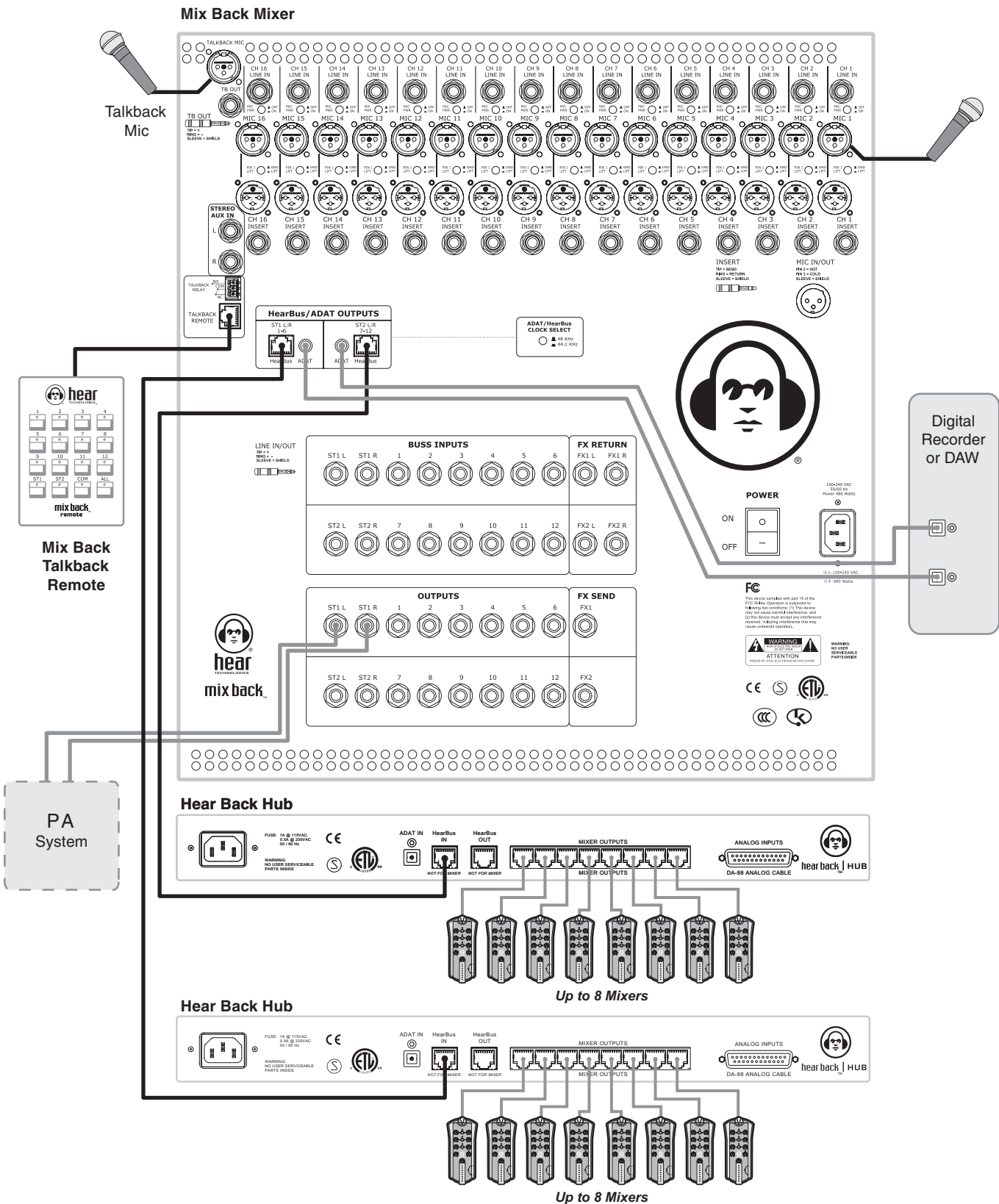

MULTI-ZONE BACKGROUND / FOREGROUND MUSIC WITH PAGING

HOOK-UP DIAGRAM

Mix Back works great as a zoned music system with paging. You can have up to eight stereo sources and zones, or up to fourteen mono zones and sources. When using mono zones, paging (talkback) occurs on both left and right of the two stereo (ST1 L/R and ST2 L/R) outputs.

Note: Paging (talkback) does not duck the music, but it is adjustable to overcome the music.

The talkback Intercom relay can trigger other devices, such as pre-recorded messages, lamps, or other control device.

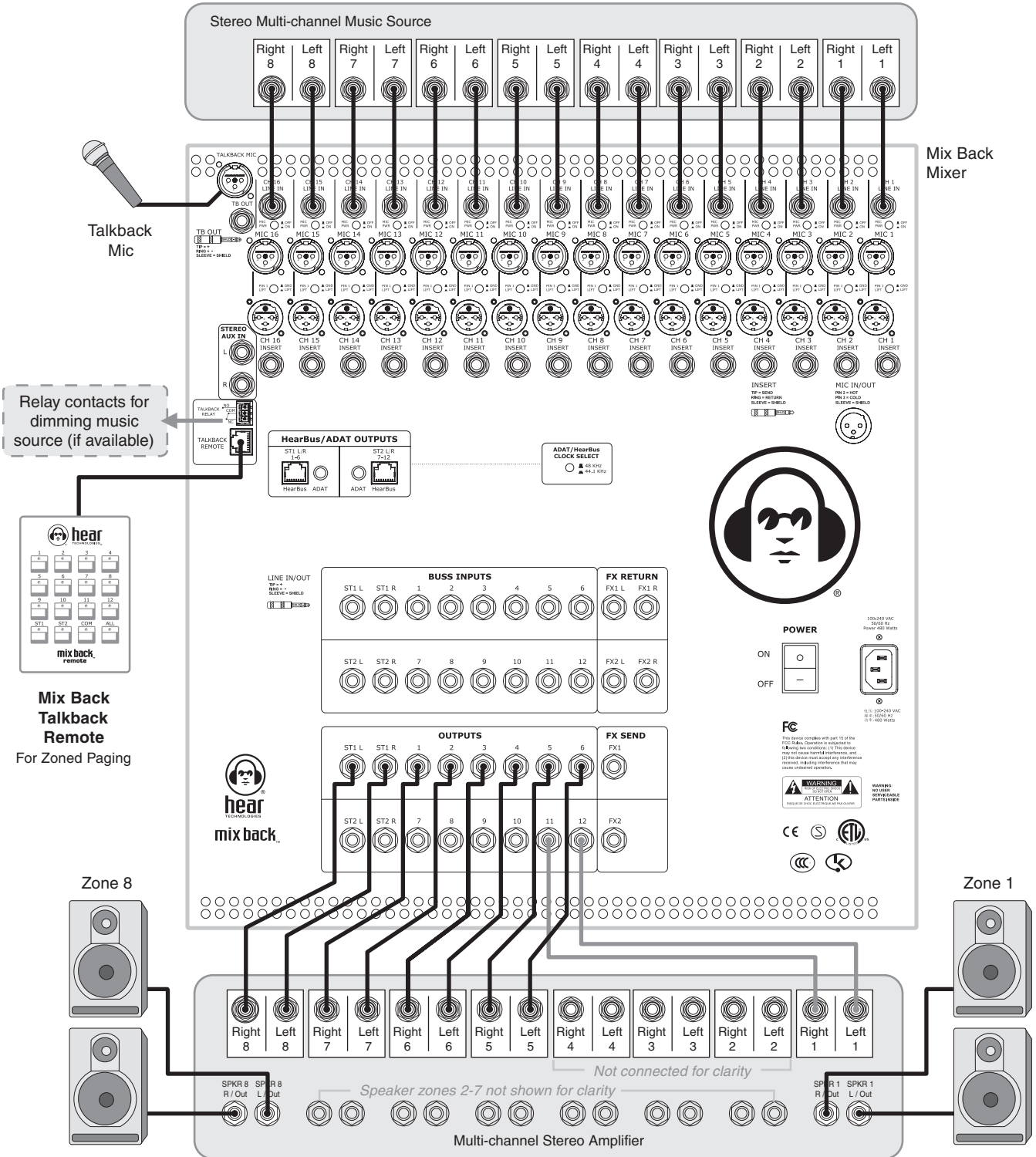

CONVENTIONAL MONITOR MIXING (UP TO FOURTEEN MONITORS)

1. Connect microphone or line inputs to the Mix Back input channels.
2. Connect the mic outputs to the FOH board.
3. Connect the Mix Back Master outputs to an equalizer, and then the equalizer outputs to the power amps or powered monitors.

Adjust all input channels "Mono Level 1" to the Master 1 output to obtain the mix for that monitor. Repeat for all twelve mono Master outputs.

Pan all ST1 and ST2 pan controls full left (or right) and the ST1 or ST2 level controls to derive the two additional mono monitor mixes.

HOOK-UP DIAGRAM

Optionally, you may use ST1 and ST2 outputs to derive two stereo monitor mixes. This option yields twelve mono mixes and two stereo mixes.

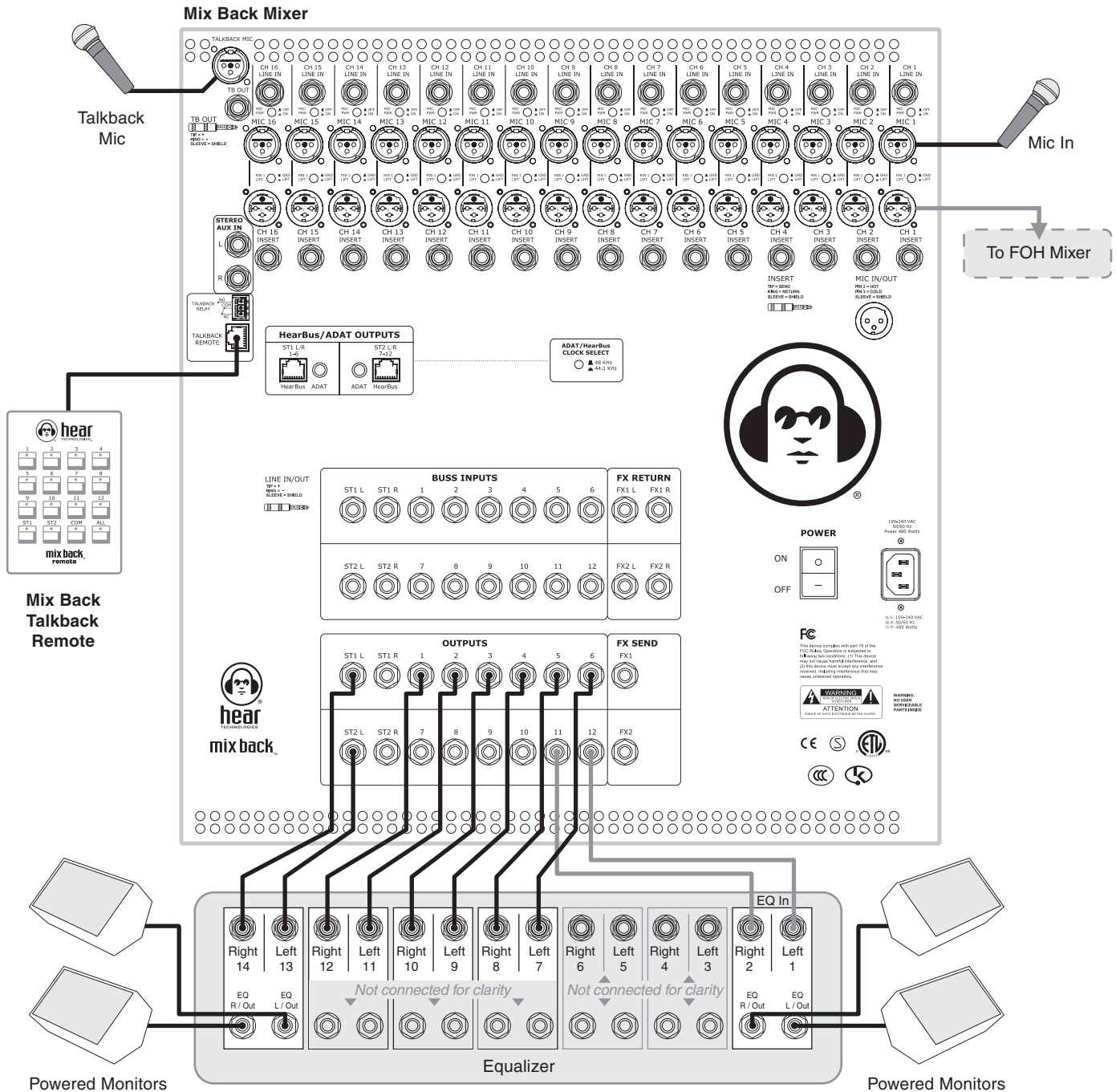

CONNECTORS

LINE INPUT/OUTPUT CONNECTORS:

¼" TRS Balanced

- Tip = Signal +
- Ring = Signal -
- Sleeve = Shield

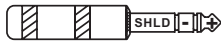

CHANNEL INSERT CONNECTORS:

¼" TRS

- Tip = Send
- Ring = Return
- Sleeve = Ground



XLR FEMALE CONNECTORS:

- 1 = Shield
- 2 = Mic +
- 3 = Mic -



XLR MALE CONNECTORS:

- 1 = Shield
- 2 = Mic +
- 3 = Mic -



HearBus RJ45 Pin Outs:

Pin	Function
1	Digital Audio +
2	Digital Audio -
3	Ground
4	+18 VDC
5	-18 VDC
6	Ground
7	+18 VDC
8	-18 VDC

Remote Control RJ45 Pin Outs:

Pin	Function
1	Digital +
2	Digital -
3	Ground
4	+18 VDC
5	No Connect
6	Ground
7	+18 VDC
8	No Connect

TALKBACK RELAY OUTPUT:

- 1 = Normally Open (Top Pin)
- 2 = Common (Center Pin)
- 3 = Normally Closed (Bottom Pin)

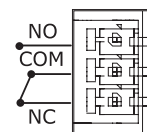



MIX BACK SYSTEM ACCESSORIES

MIX BACK TALKBACK REMOTE CONTROL

The Mix Back Remote Control is a sixteen-button remote that routes the talkback microphone signal to all master outputs and to the balanced talkback output (COM).

It features a built-in threaded Mic adapter for easy attachment to microphone and music stands using our MSA adapter or may be directly mounted to a mic stand.

The remote connects to the Mix Back using standard CAT5e cable.



Mix Back Talkback Remote

MICROPHONE STAND ADAPTER

The MSA Mic Stand Adapter is for mounting the Hear Back Mixer or a Mix Back talkback remote control to the side of any mic stand or standard music stand. The perfect companion to the Hear Back Mixer and the Mix Back talkback remote control.





OTHER HEAR TECHNOLOGIES PRODUCTS

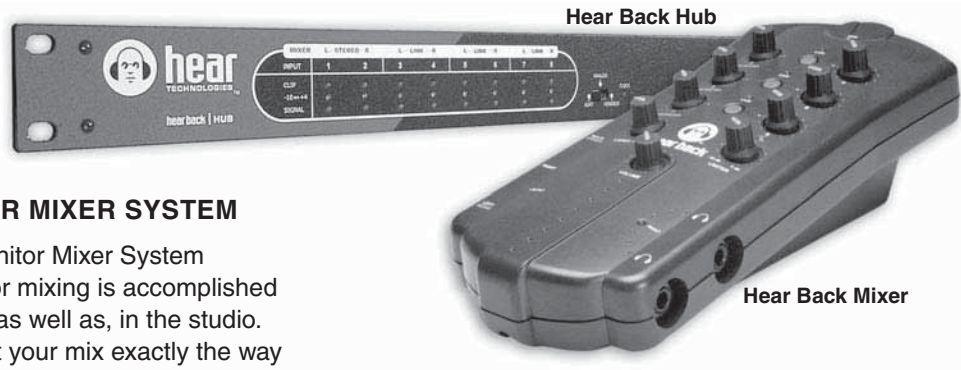

HEAR BACK PERSONAL MONITOR MIXER SYSTEM

Hear Back Personal Monitor Mixer System changes the way monitor mixing is accomplished on stage or auditorium; as well as, in the studio. With Hear Back, you get your mix exactly the way you want it, the first time. This affordable system is perfect for headphones, wired and wireless in-ear monitors, and/or conventional floor monitors. A basic Hear Back system consists of a Hub and personal Mixers connected using standard CAT5E cables. A single Hub supplies signal and power to a maximum of eight Mixers. The Hubs can be daisy-chained using the HearBus In and Out for virtually unlimited system size. The Hear Back Hub can accept analog input signals from audio mixers, auxiliary, matrix, monitor, and/or direct outputs.

TALK BACK 600 MV

The Talk Back 600 MV adds talk back, monitor master volume, monitor switching, and monitor dimming capability to recording consoles, digital hard disc recording systems, and portable audio workstations. Intended applications include professional and project recording studios and video post-production facilities.

The Talk Back 600 MV provides control room talk back to the talent. Talk Back permits the engineer to control talk back and monitor switching from the front panel and/or multiple wired remote controls (models RC-1 and RC-2). Optional IR wireless Producer Remotes are available for control of the talk back function (models IR-1 and IR-2) and may be used in conjunction with wired remotes. The unit's features and specifications rival those found only in large format recording consoles.

Talk Back 600 MV



Wired and Wireless Remotes (IR / RC)



EXTREME EXTENDERS

The Extreme Extenders were designed to solve ADAT Optical distance limitations. Using CAT5e, the effective length of an ADAT Optical interface can be extended up to 500 feet without any loss of audio quality. The ADAT "Thru" output provides a buffered pass-thru for connection to local ADAT devices.



Extreme Extender ADAT In

Extreme Extender ADAT Out

HEARBUDS & HEADSET MONITOR

Hearbuds provide an affordable in-ear monitor headset that delivers professional performance at a great value. By creating acoustic chambers at the ear, hearbuds not only dramatically improve the sound of standard in-ear headphones and ear-pieces, their molded, 100% silicon, design also significantly reduces unwanted background noise levels – enabling you to enjoy sound clarity at lower volumes. And, because they're audiologically designed, they're comfortable to wear and won't fall out of your ears!



CABLES

Hear Technologies offers a variety of quality cables that work with your system including CAT5e, Optical, and Analog DA-88 style cables.



Glossary of Terms

1. **More Me:** This term refers to personal individual monitoring levels.
Example: When the talent tells the engineer - I need to hear "more me".
2. **FOH:** Acronym which means Front Of House - such as FOH mixer
3. **PA:** Stands for Public Address such as a sound system to make voice or music louder.
4. **Perfect Mix:** Used by Hear Technologies to explain the baseline mix. You may think of it as any of the following:
 - Control Room Mix - also known to as "two mix"
 - A stereo FOH mix for the PA
 - CD recording
 - What you're selling

When using conventional monitors, musicians and singers hear direct and reflected sound allowing them to experience spatial sound information.

When using in-ear monitors the talent have their ears plugged and cannot hear the important direct and reflected ambient sounds experienced as with stage monitors or listening acoustically.

The "perfect mix" restores this valuable physco-acoustic information to the performers.

We highly recommended a "perfect mix" for every performer using in-ear systems to deliver the spatial information experienced while performing without in-ear or headphone systems.

Even if you use a mono PA system, such as a single point source cluster or simple mono PA system, one should create a stereo FOH mix and send it to the monitoring system as the "perfect mix". We feel this is the best way to achieve a natural feel for the talent when using in-ear systems.
5. **FX/EFX:** Acronyms or slang used for "effects unit". Reverb, delay, etc. are examples of such.
6. **TRS Balanced:** This refers to a connector type that carries a balanced (plus and minus) signal pair as well as an overall shield
7. **Gain:** The amount of amplification (voltage, current or power) of an audio signal, usually expressed in units of dB. While similar to level, it is a more critical adjustment that insures maximum gain is reached without distortion and to reduce signal to noise ratio.

8. **Level:** This is also referred to as volume.
9. **ADAT®:** A registered trademark of the Alesis Corporation and taken from the acronym "DAT." ADAT (Alesis Digital Audio Tape) is the name Alesis chose in the early 1990's for their ground-breaking product, which records eight tracks digitally on a standard 1/2" SVHS video cassette. The ADAT has been arguably the most significant technology/price breakthrough for recording studios in the last 20 years and has undoubtedly changed the face of modern recording forever. The ADAT has gone through several generations and is currently a 24-bit digital format. The ADAT optical connections for transferring digital data 8-tracks at a time have become a standard of the industry and used in a wide range of products from many manufacturers.
10. **dB:** Equal to one-tenth of a bel, named after Alexander Graham Bell. Since the Bel was a very large unit, the Decibel (first used in telephony in 1929 by W. H. Martin) became the new name for the transmission unit, where signal loss is a logarithmic function of the cable length. This is still very much in use today.

The dB is the preferred method and term for representing the ratio of different audio levels. Being a ratio, decibels have no units. Everything is relative. Since it is relative, then it must be relative to some 0 dB reference point.

To distinguish between reference points a suffix letter is added as follows:
 - a. 0 dBu: Preferred informal abbreviation for the official dB (0.775 V); a voltage reference point equal to 0.775 Vrms. +4 dBu Standard pro audio voltage reference level equal to 1.23 Vrms.
 - b. 0 dBV: Preferred informal abbreviation for the official dB (1.0 V); a voltage reference point equal to 1.0 Vrms.
 - c. -10 dBV: Standard voltage reference level for consumer and some pro audio and is typically equal to 0.316 Vrms.
 - d. 0 dBm: A power reference point equal to 1 milliwatt. To convert into an equivalent voltage level one must specify impedance. For example, 0 dBm into 600 ohms gives an equivalent voltage level of 0.775 V, or 0 dBu
 - e. 0 dB SPL: A reference point for the threshold of hearing, equal to 20 micro Pascals, rms.
 - f. dBA: Popular way of stating loudness measurements made using an A-weighting curve.

Glossary of Terms

11. Octave

- a. In audio, an octave is the interval between any two frequencies having a ratio of 2 to 1. *Example: 100 Hz and 200 Hz are an octave apart.*
- b. In music, an octave is the interval of eight diatonic degrees between two tones, one of which has twice as many vibrations per second as the other. *Example A1 and A2 on a piano are an octave apart.* Although similar to audio, some instruments are not exactly two times the frequency due to what's known as stretched temperament. In equal temperament, the ratio of frequencies in a semitone is the twelfth root of two ($^{12}\sqrt{2}$).
Every interval is then simply a certain number of semitones. Only the octave (the twelfth power of the twelfth root) is a pure interval.

12. **Haas Effect:** Also called the precedence effect, describes the human psycho-acoustic phenomena of correctly identifying the direction of a sound source heard in both ears but arriving at different times. Due to the head's geometry the direct sound from any source first enters the ear closest to the source, then the ear farthest away. The Haas Effect tells us that humans localize a sound source based upon the first arriving sound if the subsequent arrivals are within 25-35 milliseconds. The Haas Effect is named after Helmut Haas, a distant relative of Scott Haas.

13. **Psycho-acoustics:** The scientific study of sound perception. The effect experienced when a singer/player hears sounds and sound reflections around them while performing.

14. **In-ear monitors:** A variety of devices that are similar to headphones that fit inside one's ears. There are many manufacturers and varying levels of quality for these devices. Popular in the professional musician arena are the custom ear molds for in-ear devices. Generally in-ear, custom molds are made by an audiologist and insure a comfortable and perfect fit.

15. **Cue Mix:** A term generally used to describe audio sent to the talent headphones in recording studios (see "perfect mix").

16. **Talk Back®:** A feature used in the recording industry that permits the recording engineer to talk to the talent in the studio.

17. **EQ:** An acronym frequently used to refer to equalization or tone controls.

Limited Warranty

Hear Technologies warrants the equipment against defects in materials and labor for a period of one year from the original date of purchase. The duration of this warranty is limited to claims made to Hear Technologies within the periods stated with respect to parts and labor from the date of purchase. During the warranty period, defective equipment will be replaced or repaired to the general condition as received, at the discretion of Hear Technologies.

All transportation is the responsibility of the purchaser or owner. Equipment should be shipped in the original shipping box.

This warranty applies only to defects in materials and workmanship and does not cover failure or damage due to shipping loss or damage, abuse, misuse, misapplication, incorrect or varying power line voltages, lack of proper maintenance, natural disasters, acts of God, or unauthorized modifications, repairs, or any alterations

done without the expressed written consent by Hear Technologies. Hear Technologies shall not be liable for any loss of use of the equipment, or consequential damages, including damages to other parts of the installation in which the equipment is a part.

Hear Technologies does not make any warranty, express or implied, other than the warranty contained herein. No agent, representative, or employee has the authority to increase or alter the liability, obligations, and terms of this warranty or sale of the equipment. NOTE: It is strongly recommended that any equipment returned to Hear Technologies be properly packaged and insured for its full value in case of loss, handling or shipping damage.

Hear Technologies shall not be responsible for damage or loss of equipment during shipment.

The following are registered trademarks of Hear Technologies: Hear Technologies, Hear Back, Control Your Mix, Talk Back, Extreme Extender, Hearbuds, HearBus, and the "Jack" logo.

All names and marks of other companies belong to those respective companies.

NOTES



HEAR TECHNOLOGIES
991 Discovery Drive
Huntsville, AL 35806
Phone: +1-256-922-1200
Fax: +1-256-922-1221
www.HearTechnologies.com

Part No. LIT002720UG
©2005, Hear Technologies
02-2006