

UBB1002

EURORACK

User's Manual

Version 1.0 November 2002

ENGLISH

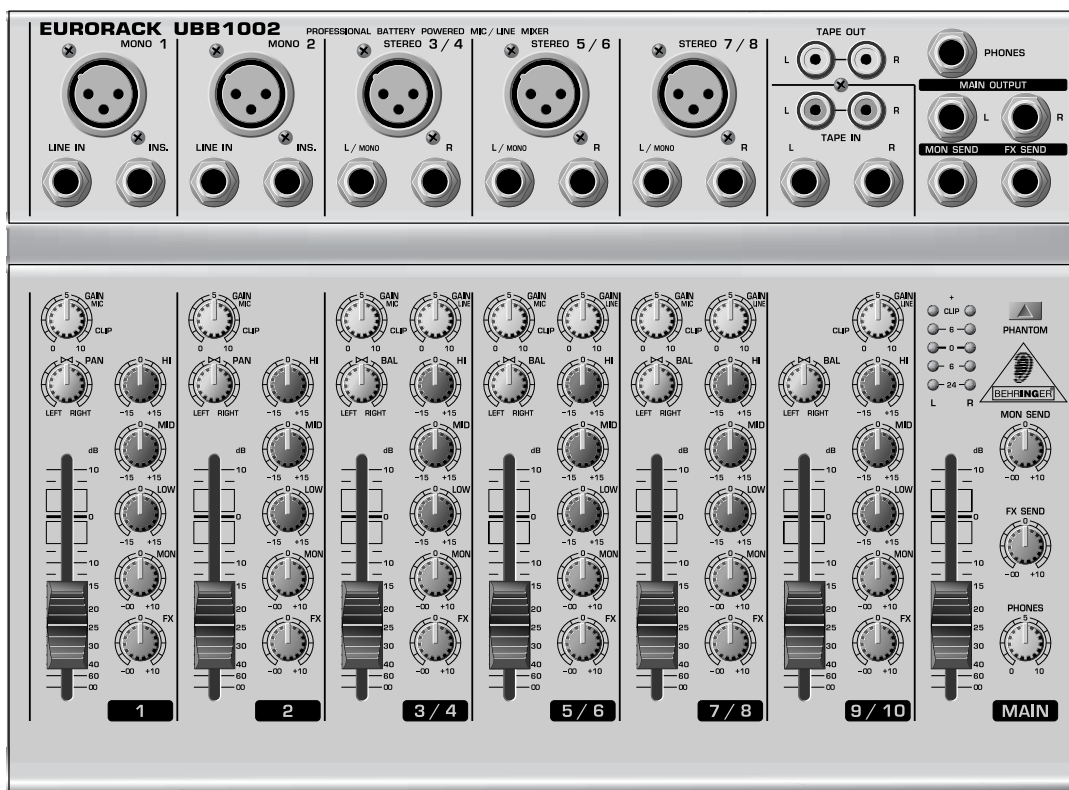

www.behringer.com

EURORACK UBB1002

SAFETY INSTRUCTIONS



CAUTION: To reduce the risk of electric shock, do not remove the cover (or rear). No user serviceable parts inside; refer servicing to qualified personnel.

WARNING: To reduce the risk of fire or electric shock, do not expose this appliance to rain and moisture.



This symbol, wherever it appears, alerts you to the presence of uninsulated dangerous voltage inside the enclosure—voltage that may be sufficient to constitute a risk of shock.



This symbol, wherever it appears, alerts you to important operating and maintenance instructions in the accompanying literature. Please, read the manual.

DETAILED SAFETY INSTRUCTIONS:

All the safety and operation instructions should be read before the appliance is operated.

Retain Instructions:

The safety and operating instructions should be retained for future reference.

Heed Warnings:

All warnings on the appliance and in the operating instructions should be adhered to.

Follow instructions:

All operation and user instructions should be followed.

Water and Moisture:

The appliance should not be used near water (e.g. near a bathtub, washbowl, kitchen sink, laundry tub, in a wet basement, or near a swimming pool etc.).

Ventilation:

The appliance should be situated so that its location or position does not interfere with its proper ventilation. For example, the appliance should not be situated on a bed, sofa, rug, or similar surface that may block the ventilation openings, or placed in a built-in installation, such as a bookcase or cabinet that may impede the flow of air through the ventilation openings.

Heat:

The appliance should be situated away from heat sources such as radiators, heat registers, stoves, or other appliances (including amplifiers) that produce heat.

Power Source:

The appliance should be connected to a power supply only of the type described in the operating instructions or as marked on the appliance.

Grounding or Polarization:

Precautions should be taken so that the grounding or polarization means of an appliance is not defeated.

Power-Cord Protection:

Power supply cords should be routed so that they are not likely to be walked on or pinched by items placed upon or against them, paying particular attention to cords and plugs, convenience receptacles and the point where they exit from the appliance.

Cleaning:

The appliance should be cleaned only as recommended by the manufacturer.

Non-use Periods:

The power cord of the appliance should be unplugged from the outlet when left unused for a long period of time.

Debris and Liquid Entry:

Care should be taken that debris and/or liquids do not enter the enclosure through openings.

Damage Requiring Service:

The appliance should be serviced by qualified service personnel when:

- ▲ The power supply cord or the plug has been damaged; or
- ▲ Debris or liquid has entered the appliance; or
- ▲ The appliance has been exposed to rain; or
- ▲ The appliance does not appear to operate normally or exhibits a marked change in performance; or
- ▲ The appliance has been dropped, or the enclosure damaged.

Servicing:

The user should not attempt to service the appliance beyond that which is described in the operating instructions. All other servicing should be referred to qualified service personnel.

EUORACK

Ultra low-noise design 10-input 2-bus mic/line mixer with optional battery operation

- ▲ Ultra low-noise ULN design, highest possible headroom, ultra-transparent sound
- ▲ Optional mains or battery operation
- ▲ Separate gain controls for mic and line inputs on all stereo channels—allowing parallel mic and line operation
- ▲ 5 new state-of-the-art, studio-grade mic preamps with outstanding dynamic range, ultra-wide gain range and lowest possible distortion
- ▲ Effective, extremely musical 3-band EQ on all channels
- ▲ 10 balanced high-headroom line inputs
- ▲ 1 post fader FX send and 1 pre fader MON send per channel for external FX devices and monitor applications
- ▲ Clip LEDs on all channels and dedicated inserts on all mono channels
- ▲ Multi-functional stereo tape/return channel for added flexibility
- ▲ Balanced main mix outputs plus separate stereo tape and headphones outputs
- ▲ Switchable phantom power for condenser microphones
- ▲ Long-wearing 60 mm logarithmic-taper ALPS® faders and sealed rotary controls
- ▲ External power supply for noise-free audio and superior transient response
- ▲ Extremely rugged steel construction ensures long life even under the most demanding conditions
- ▲ Rack mounting brackets included
- ▲ Manufactured under ISO9000 certified management system

EUORACK
UBB1002

FOREWORD



Dear Customer,

I'm sure you're one of those people who have devoted themselves body and soul to your chosen area and no doubt this has transformed you into an expert in your field!

Well, for over 30 years, my passion has been music and electronics. This not only led me to establish BEHRINGER, but also enabled me to convey and share my enthusiasm with my employees.

During all the years I've been involved with studio technology and end users,

I have developed a feel for the things that really count, such as sound quality, reliability and ease of use. What's more, I have always had the desire to push the boundaries of technical possibilities to the extreme.

It was precisely this motivation that prompted me to start work on a new series of mixing consoles. Since our EURORACKs had already set new standards world-wide, I knew the development objectives behind the products bearing my initials had to be especially ambitious.

Thus, the concept and design of the new UB mixing consoles bear my signature. The design work, the entire circuit diagram and PCB development, and even the mechanical concepts are my own work. I carefully selected each individual component—with the aim of pushing the mixing consoles' analog and digital technologies to their limits.

My vision was to enable you, the user, to give free rein to your true potential and creativity. The result is incredibly powerful mixing consoles that offer intuitive operation. They cannot fail to impress with their extremely flexible routing possibilities plus fantastic wealth of functions.

Your new UB mixing console is of high quality yet is simple to use; you'll soon appreciate that I, both personally and in my capacity as musician and sound engineer, put you, the end user, first and that these products were only possible because of the passion and the attention to detail that went into them.

Thank you for the confidence you have placed in us by purchasing the UB mixing console. I should also like to thank all those who, with their personal commitment and passion, have helped me realize this impressive series of mixing consoles.

Kindest regards,

Uli Behringer

TABLE OF CONTENTS

1. INTRODUCTION	4
1.1 Before you begin	4
1.2 Power supply	4
1.3 Control elements	5
1.3.1 Interface panel	5
1.3.2 Front panel	5
1.3.3 Main section	5
2. WIRING	6
3. SPECIFICATIONS	6
4. WARRANTY	7

1. INTRODUCTION

Congratulations! With the UBB1002 you have purchased a state-of-the-art 10-channel mixing console that sets new standards. Our prime goal when developing the UBB1002 was to design a console that can be used for a great variety of applications. And to give you maximum flexibility, you can operate the UBB1002 both from the mains and from batteries.

In combination with its comprehensive range of features and pro-level connections, the UBB1002 will be your perfect tool for any kind of application: broadcasting, video dubbing or giving the sound of your band its finishing touch.

1.1 Before you begin

Your EURORACK UBB1002 was carefully packed in the factory and the packaging is designed to protect the unit from rough handling. Nevertheless, we recommend that you carefully examine the packaging and its contents for any signs of physical damage, which may have occurred during transit.

 **If the unit is damaged, please do not return it to BEHRINGER, but notify your dealer and the shipping company immediately, otherwise claims for damage or replacement may not be granted. Shipping claims must be made by the consignee.**

Be sure that there is enough space around the unit for cooling and please do not place the UBB1002 on high-temperature devices such as radiators, etc. to avoid overheating.



1.2 Power supply

There are two options for operating the UBB1002: When using **mains power**, make sure the console is switched off before you connect it to the power supply. Then, connect it to the mains and switch the UBB1002 on, using switch  on the rear. Please note that the console and its power supply will get warm during operation, which is completely normal. For **battery operation**, you'll only need two commercial 9-V batteries of the 6LR61 type. Insert the batteries in the battery compartment on the bottom side of the unit. To use the phantom power supply, please insert another battery in the separate phantom power section of the battery compartment. **Your UBB1002 operates about 4 hours from high-grade alkaline batteries (see chapter 3).**

 **When the unit is not in use or operates from mains power, please remove the batteries!**

1.3 Control elements

1.3.1 Interface panel

- [1] Use this balanced *XLR* jack to connect a microphone to the UBB1002 (applies to channels 1 through 7/8).
-  The phantom power required for condenser mics can be activated with switch [20]. Please note that in battery-operated mode the phantom power provided is only +18 V!
- [2] Channels 1 and 2 feature an additional *LINE* input on a balanced 1/4" jack.
- [3] The *INSERT* jack allows you to insert, for example, a compressor or equalizer in the mono channels.
- [4] These are the two balanced *LINE* inputs on 1/4" jacks for the left and right sides of the stereo channels, which can be used in parallel to the microphone inputs.
- [5] Use the *TAPE OUT* jacks to connect, for example, a tape deck for recording applications.
- [6] The *TAPE IN* jacks (on stereo RCA and 1/4" jacks) allow for the connection of play-back devices such as CD players, etc. Use either the RCA or the 1/4" jacks.
- [7] Use the *PHONES* jack to connect a commercially available pair of headphones.
- [8] These are the balanced 1/4" jack *MAIN OUTPUTS* of your UBB1002 that can be used to drive, e.g. a power amplifier.
- [9] The *MON SEND* connector provides the monitor signal of your UBB1002, for example, to control a monitor amplifier or active monitor speaker.
- [10] Connect the *FX SEND* connector to the input of an external effects device.
-  The UBB1002 has no dedicated *FX Return* connectors. However, you can connect the outputs of an external effects device to the 1/4" jack inputs of the stereo channels or channels 9/10. In this case, the stereo channel's *FX* control must be set to -∞ to avoid any feedback problems.

1.3.2 Front panel

The mono channels 1 and 2 of your UBB1002 feature the same control elements. Therefore, the following description of channel 1 also applies to channel 2.

- [11] The *GAIN MIC* control determines the channel's input gain, both for a microphone connected via the *XLR* jack and for other signal sources connected to the 1/4" jack. Adjust the signal gain so that the Clip LED below the control lights up during peak signal only, but never permanently. In battery-operated mode the Clip LED is switched off.
- [12] Use the *PAN* control to adjust the signal's position on the stereo basis.
- [13] Your UBB1002 comes with a 3-band equalizer: the *HI* control governs the high frequency range, the *MID* control can be used to boost/cut the midrange frequencies, and the *LOW* control allows you to raise or lower the gain of the bass range.
- [14] The *CHANNEL* fader adjusts the volume of the corresponding channel.
- [15] Use the *MON* control to determine the channel volume sent to the monitor mix bus. When set fully to the left, the channel volume in the monitor mix is zero.
- [16] The *FX* control adjusts the effects volume for the corresponding channel.

The stereo channels 3/4, 5/6, and 7/8 differ from channels 1 and 2 – not only with regard to the connectors provided. They also have two *GAIN* controls, i.e. you can connect a microphone and a stereo line signal at the same time!

 When you connect a microphone to a stereo channel on the UBB1002, the input gain is governed by the *GAIN MIC* control!

- [17] The *GAIN LINE* control is used to adjust the line input gain. Here, too, the signal can be monitored visually with the Clip LED.
- [18] The *BAL* control performs two functions: When you connect a microphone via the *XLR* connector, or another signal source via the *L/MONO* jack, the *BAL* control determines the signal position on the stereo basis. When both 1/4" jack inputs (*L* & *R*) are used, the *BAL* control adjusts the volume balance of the two sources connected.

Except for the *GAIN MIC* control and a different set of connectors, the channels 9/10 feature the same control elements as the stereo channels. See [5] & [6] and [13] through [18].

1.3.3 Main section

- [19] The *LEVEL DISPLAY* reads the output level of your UBB1002. Make sure that the two Clip LED's won't light up.
- [20] Use this switch to activate the phantom power required for condenser microphones. In battery-operated mode the phantom power provided is only +18 V!
- [21] The *MON SEND* control adjusts the volume level of the monitor signal provided at connector [9].
- [22] Use the *MASTER* fader to set the overall volume level of your UBB1002.
- [23] The *FX SEND* control allows you to adjust the level that is sent to an external effects device via connector [10]. Thus, you can drive all types of effects devices without any risk of distortion.
- [24] The *PHONES* control governs the headphones volume.
- [25] Connect the enclosed power supply to the *AC POWER IN* jack.
- [26] Use the *POWER ON* switch to switch on your UBB1002, which is indicated by the LED below the *LEVEL DISPLAY* [19].
- [27] *SERIAL NUMBER*. Please take the time to have the warranty card filled out completely, and return it within 14 days after the date of purchase, so as to be entitled to benefit from our extended warranty. Or use our online registration option available on the World Wide Web at www.behringer.com).

2. WIRING

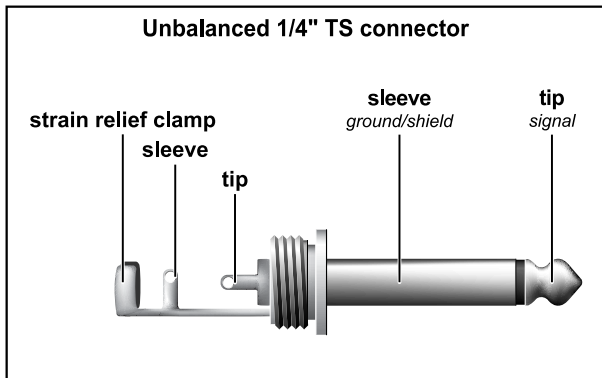

Fig. 2.1: 1/4" mono plug

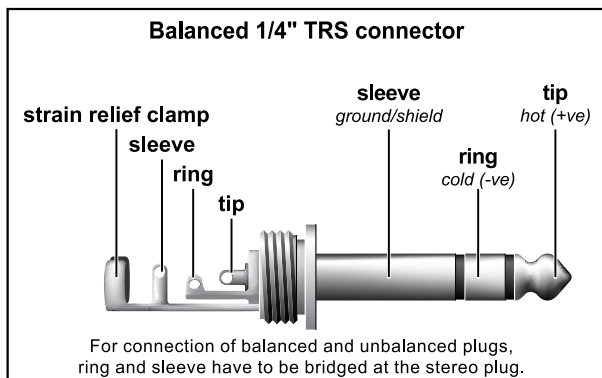

Fig. 2.2: 1/4" stereo plug

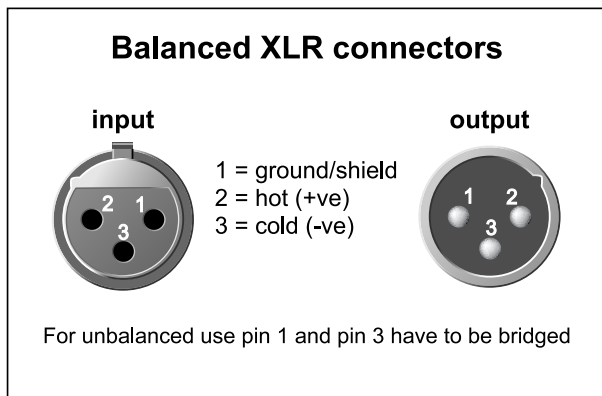

Fig. 2.3: XLR connections

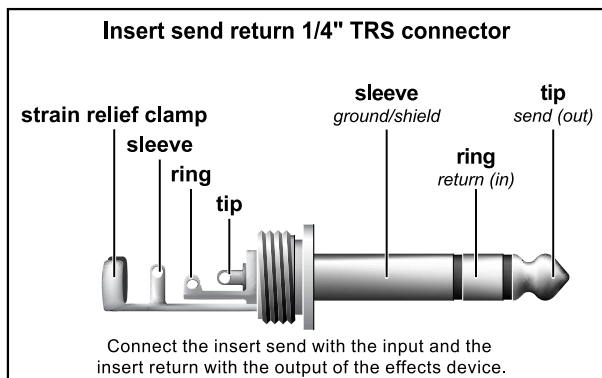

Fig. 2.4: Insert send/return stereo plug

1/4" TRS headphones connector

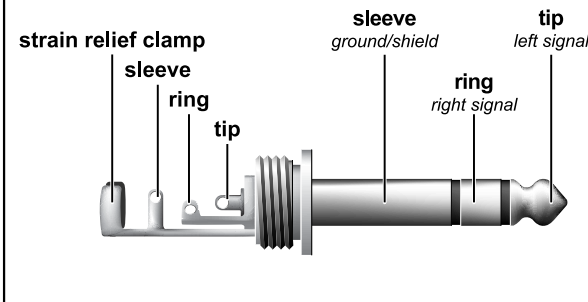

Fig. 2.5: Stereo plug for headphones connection

3. SPECIFICATIONS

INPUT CHANNELS 1 & 2

Mic input	electronically balanced, discrete input configuration
Frequency response	10 Hz to 200 kHz
Gain range	+14 dB to +60 dB
SNR	120 dB E.I.N.
Line input	electronically balanced
Frequency response	10 Hz to 130 kHz
Gain range	-6 dB to +38 dB
SNR	95 dB E.I.N.

STEREO CHANNELS 3/4 - 7/8 & 9/10

Frequency response	10 Hz to 70 kHz
Gain range	Line: -∞ to +15 dB / Mic: +13 to +60 dB
SNR	Line: 96 dB / Mic: 104 dB E.I.N.

EQUALIZATION

LOW	50 Hz, +/- 15 dB
MID	700 Hz, +/- 15 dB
H	10 kHz, +/- 15 dB

MAIN MIX

Main Outputs	+28 dBu balanced / +22 dBu unbalanced
Mon Send	+22 dBu unbalanced
FX Send	+22 dBu unbalanced
Tape Out	+22 dBu unbalanced
Phones Output	+15 dBu / 150 Ω

POWER SUPPLY

Mains voltage	USA/Canada 120 V~, 60 Hz, Power Supply MXUL4 U.K./Australia 240 V~, 50 Hz, Power Supply MXUK4 Europe 230 V~, 50 Hz, Power Supply MXEU4 Japan 100 V~, 50 - 60 Hz, Power Supply MXJP4
Battery life	approx. 4 h (with Duracell® Alkaline Type MN1604 / 580 mAh)

PHYSICAL

Dimensions (H x W x D)	approx. 1 9/16" (40 mm) / 2 7/8" (73 mm) x 11 3/4" (298 mm) x 8 1/2" (216 mm)
Weight	approx. 2.5 kg (5 1/2 lbs), PSU not included

BEHRINGER is constantly striving to maintain the highest professional standards. As a result of these efforts, modifications may be made from time to time to existing products without further notice. Specifications and appearance may differ from those listed or shown.

4. WARRANTY

§ 1 WARRANTY CARD/ONLINE REGISTRATION

To be protected by the extended warranty, the buyer must complete and return the enclosed warranty card within 14 days of the date of purchase to BEHRINGER Spezielle Studioteknik GmbH, in accordance with the conditions stipulated in § 3. Failure to return the card in due time (date as per postmark) will void any extended warranty claims. Based on the conditions herein, the buyer may also choose to use the online registration option via the Internet (www.behringer.com or www.behringer.de).

§ 2 WARRANTY

1. BEHRINGER (BEHRINGER Spezielle Studioteknik GmbH including all BEHRINGER subsidiaries listed on the enclosed page, except BEHRINGER Japan) warrants the mechanical and electronic components of this product to be free of defects in material and workmanship for a period of one (1) year* from the original date of purchase, in accordance with the warranty regulations described below. If the product shows any defects within the specified warranty period that are not excluded from this warranty as described under § 3 and 4, BEHRINGER shall, at its discretion, either replace or repair the product using suitable new or reconditioned parts. In the case that other parts are used which constitute an improvement, BEHRINGER may, at its discretion, charge the customer for the additional cost of these parts.

2. If the warranty claim proves to be justified, the product will be returned to the user freight prepaid.

3. Warranty claims other than those indicated above are expressly excluded.

§ 3 RETURN AUTHORIZATION NUMBER

1. To obtain warranty service, the buyer (or his authorized dealer) must call BEHRINGER (see enclosed list) during normal business hours **BEFORE** returning the product. All inquiries must be accompanied by a description of the problem. BEHRINGER will then issue a return authorization number.

2. Subsequently, the product must be returned in its original shipping carton, together with the return authorization number to the address indicated by BEHRINGER.

3. Shipments without freight prepaid will not be accepted.

§ 4 WARRANTY REGULATIONS

1. Warranty services will be furnished only if the product is accompanied by a copy of the original retail dealer's invoice. Any product deemed eligible for repair or replacement by BEHRINGER under the terms of this warranty will be repaired or replaced within 30 days of receipt of the product at BEHRINGER.

2. If the product needs to be modified or adapted in order to comply with applicable technical or safety standards on a national or local level, in any country which is not the country for which the product was originally developed and manufactured, this modification/adaptation shall not be considered a defect in materials or workmanship. The warranty does not cover any such modification/adaptation, irrespective of whether it was carried out properly or not. Under the terms of this warranty, BEHRINGER shall not be held responsible for any cost resulting from such a modification/adaptation.

3. Free inspections and maintenance/repair work are expressly excluded from this warranty, in particular, if caused by improper

handling of the product by the user. This also applies to defects caused by normal wear and tear, in particular, of faders, potentiometers, keys/buttons and similar parts.

4. Damages/defects caused by the following conditions are not covered by this warranty:

▲ improper handling, neglect or failure to operate the unit in compliance with the instructions given in BEHRINGER user or service manuals.

▲ connection or operation of the unit in any way that does not comply with the technical or safety regulations applicable in the country where the product is used.

▲ damages/defects caused by force majeure or any other condition that is beyond the control of BEHRINGER.

5. Any repair or opening of the unit carried out by unauthorized personnel (user included) will void the warranty.

6. If an inspection of the product by BEHRINGER shows that the defect in question is not covered by the warranty, the inspection costs are payable by the customer.

7. Products which do not meet the terms of this warranty will be repaired exclusively at the buyer's expense. BEHRINGER will inform the buyer of any such circumstance. If the buyer fails to submit a written repair order within 6 weeks after notification, BEHRINGER will return the unit C.O.D. with a separate invoice for freight and packing. Such costs will also be invoiced separately when the buyer has sent in a written repair order.

§ 5 WARRANTY TRANSFERABILITY

This warranty is extended exclusively to the original buyer (customer of retail dealer) and is not transferable to anyone who may subsequently purchase this product. No other person (retail dealer, etc.) shall be entitled to give any warranty promise on behalf of BEHRINGER.

§ 6 CLAIM FOR DAMAGES

Failure of BEHRINGER to provide proper warranty service shall not entitle the buyer to claim (consequential) damages. In no event shall the liability of BEHRINGER exceed the invoiced value of the product.

§ 7 OTHER WARRANTY RIGHTS AND NATIONAL LAW

1. This warranty does not exclude or limit the buyer's statutory rights provided by national law, in particular, any such rights against the seller that arise from a legally effective purchase contract.

2. The warranty regulations mentioned herein are applicable unless they constitute an infringement of national warranty law.

* Customers in the European Union please contact BEHRINGER Germany Support for further details.

The information contained in this manual is subject to change without notice. No part of this manual may be reproduced or transmitted in any form or by any means, electronic or mechanical, including photocopying and recording of any kind, for any purpose, without the express written permission of BEHRINGER Spezielle Studioteknik GmbH.

BEHRINGER and EUORACK are registered trademarks. ALL RIGHTS RESERVED.

*Duracell is a registered trademark with no connection whatsoever to BEHRINGER © 2002 BEHRINGER Spezielle Studioteknik GmbH.
BEHRINGER Spezielle Studioteknik GmbH, Hanns-Martin-Schleyer-Str. 36-38, 47877 Willich-Münchheide II, Germany
Tel. +49 (0) 21 54 / 92 06-0, Fax +49 (0) 21 54 / 92 06-30