



Portable PA System / Keyboard Amplifier



# STAGEPAS 250M/150M

PORTABLE PA SYSTEM / KEYBOARD AMPLIFIER  
**STAGEPAS 250M**



PORTABLE PA SYSTEM / KEYBOARD AMPLIFIER  
**STAGEPAS 150M**



## For Keyboard Players



### All-in-one Systems

Virtually everything you need is right here in each of these systems: one versatile, powerful mixer/amplifier, two top-quality speakers (or one speaker, with the STAGEPAS 250M and 150M systems), and even the necessary speaker cables for quick setup!

### Two-way Full-range Speaker System

The STAGEPAS delivers a remarkably large and powerful sound despite its compact size—thanks to the two-way speaker system and bass reflex design. All models feature a 1" titanium tweeter. The 250M and 500 employ a 10" woofer while the 150M and 300 have an 8" woofer. The sound is exceptionally clean, clear and free from break-up, even at high levels.

### Detachable Stereo Powered Mixer

The high-performance combination mixer/amplifier comes in 8- and 10-channel configurations, providing all the inputs you need, as well as all the power you want. Fitting neatly inside one of the speaker cabinets, it can be used as is, or detached for convenient placement and easy access.

### Click Assign Switches

This convenient feature lets you connect a drum machine, synthesizer or metronome to Channels 7(8/9) and route a click or rhythm signal through the mixer for monitoring purposes only (for example, letting a drummer hear a click track in the monitor). Turning this switch on takes the Channel 7(8/9) signal out of the ST SUB OUT jacks. A second Click switch lets you route the click signal only to the PHONES out for headphones monitoring.

Portable PA System / Keyboard Amplifier



# STAGEPAS 250M/150M

*For Keyboard Players*



PORTABLE PA SYSTEM / KEYBOARD AMPLIFIER  
**STAGEPAS 250M**

PORTABLE PA SYSTEM / KEYBOARD AMPLIFIER  
**STAGEPAS 150M**

## All-in-one Systems

Virtually everything you need is right here in each of these systems: one versatile, powerful mixer/amplifier, two top-quality speakers (or one speaker, with the STAGEPAS 250M and 150M systems), and even the necessary speaker cables for quick setup!

## Two-way Full-range Speaker System

The STAGEPAS delivers a remarkably large and powerful sound despite its compact size—thanks to the two-way speaker system and bass reflex design. All models feature a 1" titanium tweeter. The 250M and 500 employ a 10" woofer while the 150M and 300 have an 8" woofer. The sound is exceptionally clean, clear and free from break-up, even at high levels.

## Detachable Stereo Powered Mixer

The high-performance combination mixer/amplifier comes in 8- and 10-channel configurations, providing all the inputs you need, as well as all the power you want. Fitting neatly inside one of the speaker cabinets, it can be used as is, or detached for convenient placement and easy access.

## Click Assign Switches

This convenient feature lets you connect a drum machine, synthesizer or metronome to Channels 7(5/6) and route a click or rhythm signal through the mixer for monitoring purposes only (for example, letting a drummer hear a click track in the monitor). Turning this switch on takes the Channel 7(5/6) signal out of the ST SUB OUT jacks. A second Click switch lets you route the click signal only to the PHONES out for headphones monitoring.

# Application Example

## Small Gig with STAGEPAS 250M

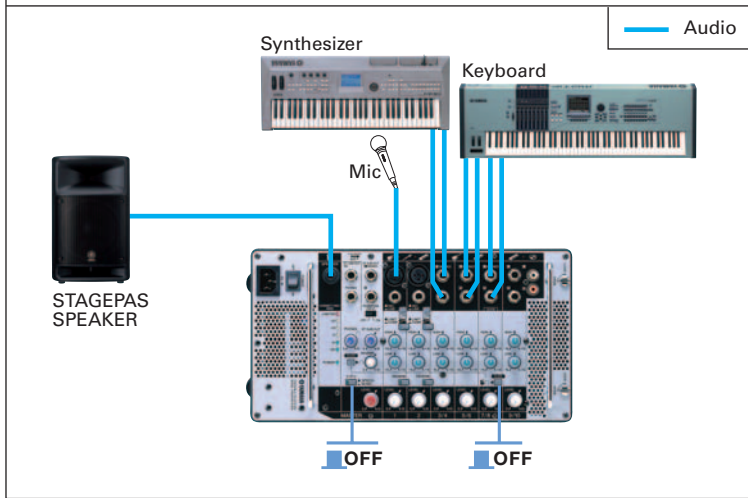

## Complete PA and Monitoring System

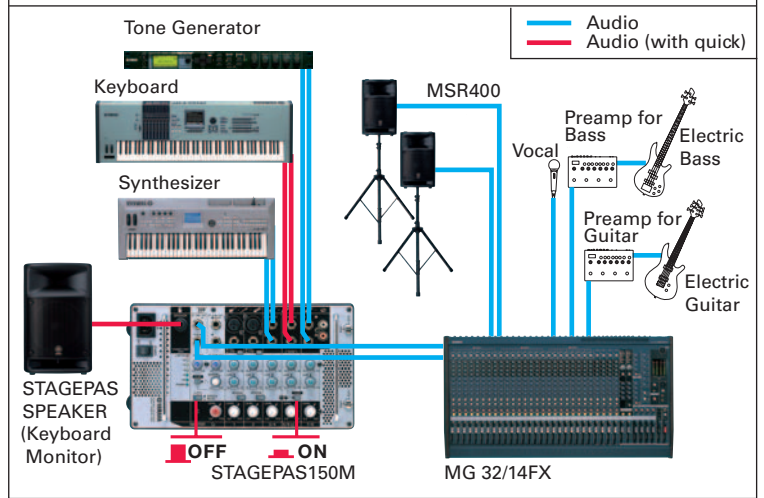

### General Specifications (Mixer)

	STAGEPAS 500	STAGEPAS 300	STAGEPAS 250M	STAGEPAS 150M
Maximum Output Power	250 W + 250 W (±10 %) 4 Ω @ 10 % THD at 1 kHz (SPEAKER L/R)	150 W + 150 W (±10 %) 6 Ω @ 10 % THD at 1 kHz (SPEAKER L/R)	250 W (±10 %) 4 Ω @ 10 % THD at 1 kHz (SPEAKER)	150 W (±10 %) 6 Ω @ 10 % THD at 1 kHz (SPEAKER)
Output Power (RMS)	200 W + 200 W 4 Ω @ 1 % THD at 1 kHz (SPEAKER L/R)	100 W + 100 W 6 Ω @ 1 % THD at 1 kHz (SPEAKER L/R)	200 W 4 Ω @ 1 % THD at 1 kHz (SPEAKER)	100 W 4 Ω @ 1 % THD at 1 kHz (SPEAKER)
Maximum Output Level	116 dB (1 m)	112 dB (1 m)	116 dB (1 m)	112 dB (1 m)
Frequency Response (Nominal output level @ 1 kHz)		-3 dB, 0 dB, +1 dB @ 20 Hz-20 kHz, 1 W Output (MUSIC/SPEECH=MUSIC, without Speaker EQ) (STAGEPAS 500/300: SPEAKER L/R) (STAGEPAS 250M/150M: SPEAKER)		
Total Harmonic Distortion		0.5 % @ 20 Hz, 1 kHz, 20 kHz +14 dBu GAIN= nominal (STAGEPAS 500/300: MONITOR OUT, REC OUT) (STAGEPAS 250M/150M: ST SUB OUT, ST LINK OUT)		
Hum & Noise (Equivalent Input Noise, R <sub>s</sub> = 150 Ω, MIC/LINE = MIC)	≤ -106 dBu (CH1/2) ≤ -112 dBu (CH3/4) ≤ -65 dBu Residual output noise (SPEAKER L/R)	≤ -65 dBu Residual output noise (SPEAKER L/R)	≤ -106 dBu (CH1/2) ≤ -65 dBu Residual output noise (SPEAKER)	≤ -112 dBu (CH3/4) ≤ -65 dBu Residual output noise (SPEAKER)
Crosstalk (1 kHz)			-70dB between input channels	
Power Consumption	65 W	70 W	35 W	20 W
Weight	24 kg (52.7/8" lbs.) (Speaker x 2 + Powered Mixer)	18 kg (39.5/8" lbs.) (Speaker x 2 + Powered Mixer)	13 kg (28.5/8" lbs.) (Speaker + Powered Mixer)	9.6 kg (21.1/8" lbs.) (Speaker + Powered Mixer)
Input Channel Equalization			±15 dB, HIGH 10 kHz shelving, LOW 100 Hz shelving	

### General Specifications (Speaker)

	STAGEPAS 500	STAGEPAS 300	STAGEPAS 250M	STAGEPAS 150M
Enclosure			2-way bass-reflex type, Polypropylene, Black	
Crossover Frequency			4.0 kHz (LF: 12 dB/oct, HF: 12 dB/oct)	
Frequency Range			55 Hz-20 kHz (-10 dB)	
Speaker Unit	LF: 10" (25 cm) Cone HF: 1" (2.54 cm) Compression Driver	LF: 8" (20 cm) Cone HF: 1" (2.54 cm) Compression driver	LF: 10" (25 cm) Cone HF: 1" (2.54 cm) Compression Driver	LF: 8" (20 cm) Cone HF: 1" (2.54 cm) Compression Driver

PORTABLE PA SYSTEM

# STAGEPAS 500/300

## Versatility and Power-in Stereo Portable Systems

Combining high-performance power and accurate sound reproduction with remarkable versatility in a portable package, Yamaha's STAGEPAS Series Portable PA Systems are fast becoming the standard for keyboardists and other PA users on the go. These combination mixer/amplifier/speaker systems are exceptionally lightweight, portable and full-featured. Since virtually everything you need is in one, easy-to-use package, you can be set up and playing within a matter of minutes. Yet despite the simplicity and compact size, these systems cut no corners in sound quality or versatility. They can also function either as an ultra-portable PA system – with sound quality and portability that far surpasses any other conventional keyboard amp. No matter what system you choose, you have a high-power, high performance sound system ready for a wide variety of venues and events, both indoors and out.



• Specifications and appearance subject to change without notice. • All trademarks and registered trademarks are property of their respective owners.

For details please contact:

**YAMAHA**  
YAMAHA CORPORATION  
P.O. BOX 1, Hamamatsu Japan  
[www.yamahaproaudio.com](http://www.yamahaproaudio.com)  
Printed in Japan



This document is printed on chlorine-free (ECF) paper with soy ink.

LPA550

