

GENZ·BENZ

SHUTTLE

6.0

OWNER'S MANUAL



PRODUCT DESCRIPTION – The SHUTTLE 6.0® bass amplifier has been designed with our unique ULTRA LIGHT unified design process, yielding a 600 watt professional, high powered, tour-class, bass guitar amplifier weighing less than 3.75 lbs! This compact design blends the best of analog and digital platforms to produce the ultimate in warmth, punch, and power.

The SHUTTLE 6.0® is equipped with a 1/4" unbalanced instrument input, input stage clip detector, mute switch with LED indicator, 12AX7 tube preamp with extended range variable input gain, 3 switched signal shape filters with LED indicators, 3 band active equalization with sweepable midrange frequency, master volume control, proprietary output limiter, 1/4" tuner output, aux. input, effects loop, balanced direct out with ground lift/pre-post/mic-line switches, headphone output, and 2 Neutrik NL-4 "Speak-On"™ speaker jacks.

The power amp is a powerful, lightweight Class D design and is supported by a state-of-the-art digital Switch Mode Power Supply (SMPS), which does away with the weight of a traditional power transformer. The SHUTTLE 6.0®'s power supply is usable from 100-240 volts, lending itself well to international touring players.

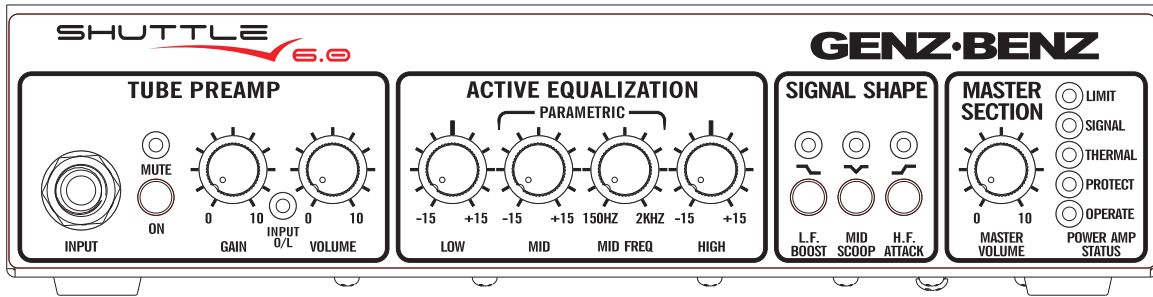

FRONT PANEL

INPUT – The SHUTTLE 6.0® is equipped with a standard ¼” unbalanced input. The input sensitivity range is from 40 mV to 1.6 volts. The input impedance is >500K ohms. The input stage contains a precision high order active high pass filter (more effective and less intrusive than the more common 6 dB filters) and an “RFI” filter (radio frequency interference) to eliminate unwanted noise. The input gain stage consists of a feedback type variable gain circuit that provides wide range, continuously variable gain with minimal noise. The preamp contains a FET input amp circuit based on our highly regarded GBE series touring amplifiers.

INPUT SIGNAL MUTE SWITCH – With this mute switch, you can place the amplifier (and Direct Output) in standby mode between sets, without having to change any of your amp settings. This feature can also be used for silent tuning since the Tuner Out stays active when the mute is engaged. A red LED indicates when the Mute is active. This function is also foot-switchable from the optional 4 button foot switch. The switch on the amplifier’s faceplate must be in the “out” position for the foot switch to work properly.

PREAMP GAIN CONTROL – This control sets the input sensitivity gain of the 12AX7 TUBE preamp to the output of your bass. The volume of the signal is then controlled by the Tube Preamp Volume control and also the Master Volume control. Note that overdriving the input tube gain stage may be a desirable tonal characteristic of your playing style. This control, in conjunction with the Preamp and Master Volume controls, allows you to set the amount of tube overdrive or clean tone your amp produces.

“O/L” LED – This “Over-load” LED senses the operating status of the preamp and EQ stages. When this LED flashes, overdriving of the input gain or EQ stage is occurring. Adjusting the Preamp Gain and Preamp Volume controls will affect the over-load condition. Again, overdriving the tube pre-amp may be a desirable tone for your playing style.

PREAMP VOLUME CONTROL – This control sets the volume of the preamp after the Input and Tube Gain stages but before the EQ, Signal Shape and Master Volume controls. Use this control in conjunction with the Gain Control.

SETTING YOUR INPUT SIGNAL – Use the following guidelines to set your amplifier input stage for the type of bass used and your personal playing style. These guidelines are just a suggested starting point.

- 1) Set your instruments controls (volume and tone) where you normally prefer to run them.
- 2) Now set all controls on the SHUTTLE to 12 o’clock. It may be best to start with the Master Volume at 9 o’clock.
- 3) For a clean tone and using a Passive bass your Tube Gain and Preamp Volume settings may be set to similar positions. For a clean tone using an Active bass your Tube Gain setting should be set more towards the 9 o’clock position and the Preamp Volume at noon to 2 o’clock positions.
- 4) For overdriven tube tones with Active or Passive basses your Tube Gain setting will be set higher and the Preamp Volume set lower. If driving the Gain Control towards maximum then the Preamp Volume should be set below the 12 o’clock position. Set your Master Volume for your desired overall volume. We suggest experimenting with different settings for best results.
- 5) Now, turn your attention to the EQ section and make the adjustments for your desired tone. Because this is an active EQ network, any larger settings of cut or boost will affect the gain level of the preamp and the O/L lights at the input stage.
- 6) After setting your EQ it may be necessary to go back and adjust your input gain level down accordingly. It should be noted that the Global Signal Shape circuits will not affect the input gain BUT will affect the Master output level and LIMIT indicator if used with extreme settings.

ACTIVE EQUALIZATION – The SHUTTLE 6.0® contains an active 3 band equalizer with sweepable parametric mid range frequency control. This equalizer, similar to those found on professional sound consoles, is a very useful tool. The low frequency EQ section is an 80 Hz shelving curve with 15dB of cut or boost. The high frequency EQ section is a 4 KHz shelving curve with 15dB of cut or boost. The parametric sweepable-mid frequency section features 15 dB of cut or boost with a bandwidth approximately 1 octave wide. The center frequency of this filter is continuously user adjustable from 150 Hz to 2 KHz with a single control. This filter is typically (but not always) used to reduce or remove offending frequencies in the instrument's pick-up response, or boost response to achieve a particular voicing. Spend some time experimenting so that the process becomes creative as well as corrective. Note that our active equalizers are very wide response and a little bit can go a long way.

SIGNAL SHAPE – The SHUTTLE 6.0® is equipped with 3 Signal Shape circuits. The L.F. BOOST adds low frequency peaking gain in the 38-67 HZ band. This filter is especially effective when used with a 5 string bass. The MID SCOOP switch generates midrange cut centered at approx. 600 Hz, the H.F. ATTACK adds a peaking high frequency boost in the 2.25-8 KHz band. LED indicators are provided to visually show when each filter is engaged. Each filter Q (bandwidth) is optimized for its particular functions and is different for each filter. These functions are also foot-switchable from the optional 4 button foot switch. The switches on the amplifier's faceplate must be in the "out" position for the footswitch to work properly.

MASTER VOLUME – The master volume control adjusts the overall volume of the amplifier and the effects return. Typically, best results are obtained when this control is operated between the 9:00 and 3:00 positions.

OUTPUT LIMITER – The SHUTTLE 6.0® contains an internal power amplifier "Soft Clip" Limiter. This Limiter allows simulation of tube output stage saturation as the amplifier nears its maximum power. The limiter is a compound multi stage analog circuit, is quite graceful in nature, and is particularly musical sounding, even when driven hard. The output "LIMIT" LED shows limiting action at the maximum power threshold and then indicates power amplifier clipping as the power amplifier gradually transitions into gentle clipping.

MASTER SECTION STATUS INDICATORS -

- The "POWER" light indicates that the amplifier is ON and the low voltage power supplies are active.
- The red "PROTECT" LED indicates that the amp is in "protect" mode. This led may flash during power turn-on and turn-off. This is normal. It will also illuminate during any internal fault condition. If this happens, turn the amp off and consult a repair technician.
- The red "THERMAL" LED indicates that the amplifier has over-heated, engaged the protection circuit and shut down. This circuit is self-resetting when the offending condition is corrected, i.e., blocked fan vents, stuck fan, 2 ohm operation, etc.
- The blue "SIGNAL" LED indicates that the power amplifier is received signal (over several watts output) and is performing properly.
- The "LIMIT" LED indicates that the power amp is near its maximum power and has entered its soft clip/limit mode. Under high output conditions this LED will light with the strongest pulses of the signal. Driving hard beyond this point will cause the amplifier to gradually begin to clip.

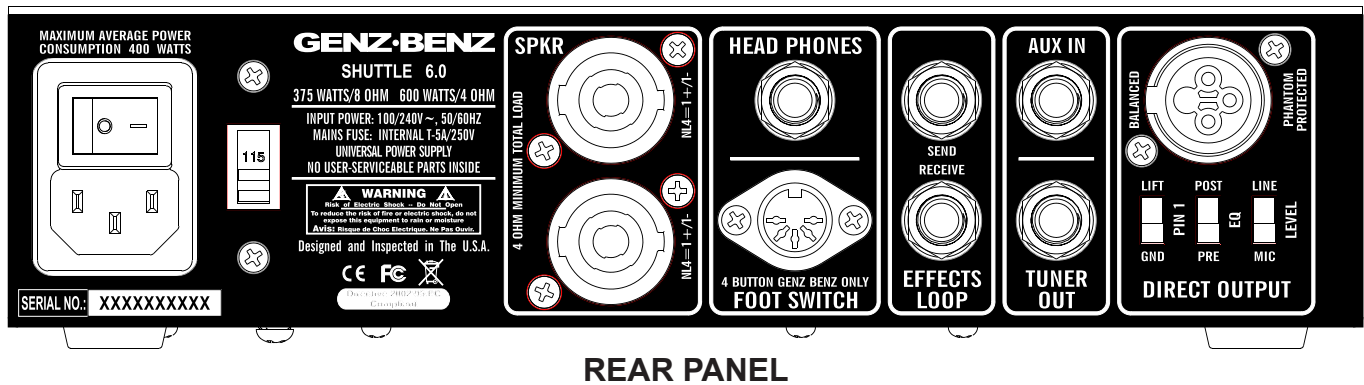

REAR PANEL

DIRECT OUTPUT – An XLR balanced direct output is provided for connection to a PA system or directly into a recording studio console or D/A converter. The Direct Out signal may be switched between mic and line level, pre and post EQ, and the audio signal ground may be connected or lifted from pin 1 to eliminate hum due to ground loops. This output is fully protected against 48 volt phantom power and may be used for driving microphone lines of up to 300 feet without problems.

TUNER OUTPUT – The SHUTTLE 6.0® is equipped with a fully isolated Tuner Output. This jack is located after the front end scaling preamplifier, but is pre-signal shape and pre-EQ. This output may also be used to drive a separate direct box or high-impedance recording device. The Tuner Output remains active when the amplifier is muted, allowing silent tuning on stage.

AUX INPUT – A 1/4" unbalanced line level aux. input is provided that sums directly to the main output bus, controlled by the master volume control. This input is ideal for practicing with recorded tracks from a CD player, IPOD, or MP-3 player. It is recommended to use a cable with left and right signals connected to a "Y" jack, summing the signal into the aux. input jack. Adjust the level of the playback source to balance with the bass guitar's volume.

EFFECTS LOOP – A rear panel effects loop (SEND and RECEIVE jacks) is provided for connecting "serial" outboard devices such as compressors and may also be used for parallel type outboard devices (delays, reverbs, harmonizers, octavers etc.) by using the mix control located on the outboard device. This loop is located right before the Master Volume control and is also intended as a Preamp Out / Power Amp In connection for possible "chaining" of amplifiers in a Master / Slave configuration. The effects "loop" contains a "normal switch" in the receive jack that interrupts the signal path when a plug is inserted into the receive jack. The send jack may be used for an aux. output without breaking the signal path.

HEADPHONE OUT – A 1/4" TRS jack is provided for connection to headphones for silent practice use. A speaker load is not required. Do not connect this output to anything but headphones.

FOOT SWITCH – This connector is for connecting the optional 4 button foot switch to the SHUTTLE 6.0®. Do not use anything but the factory supplied foot switch.

POWER AMPLIFIER – The SHUTTLE 6.0® uses a state of the art, class D power amplifier design and a high frequency switch-mode power supply (SMPS) to achieve unprecedented high performance and lightweight packaging. Switch-mode power supplies convert the AC line directly to high voltage DC, then the precision PWM (pulse width modulation) inverter creates a new AC power signal at a frequency more than 1000 times higher than the original wall frequency of 50/60Hz. This new high voltage, high frequency power signal is then fed into a custom high frequency transformer that steps the voltage down, a high frequency rectifier and high ESR filter capacitors finish the process off by converting the high frequency AC signal back to the DC voltages that the amplifier's internal circuitry uses. One advantage of this conversion process is that the DC power supply rails are refreshed more than 1000 times more often than in traditional linear supplies, thus reducing annoying hum in the audio signal. The high frequency switching is used to reduce the size and weight of the magnetic and filter components while increasing the performance by recharging the power supply rails more often. The class D amplifier uses digital PWM techniques similar to those in more familiar digital to analog converters to reduce the size and weight by a factor of 10 times that of a comparably rated conventional class AB amplifier. Essentially, a class D amplifier converts the analog signal into a logic level PWM digital signal with a digital to analog converter, level shifts this PWM signal up to a higher voltage and current and then reconstructs the analog signal by passing it through what is essentially a power digital to analog converter. Additionally, we developed our own, proprietary limiting and signal processing techniques to give a distinctly analog feel and sound to the class D platform. This system provides exceptional performance even for low frequency applications such as bass guitar.

SPEAKER OUTPUTS – The SHUTTLE 6.0® provides two Neutrik Speak-On™ connectors (wired 1+/1-). The speaker jacks are paralleled. The minimum speaker load is 4 ohms. Do not ground either the “+” or the “-” outputs.

POWER INPUT – VOLTAGE SELECTOR SWITCH - The SHUTTLE 6.0® utilizes rear panel switch selectable universal power supply that operates from 100V to 240 volts, 50 to 60 Hz for world wide use. Simply set the switch to the appropriate AC mains voltage (BEFORE connecting to the power source), and utilize the proper IEC cord-set appropriate for the country the product is being used.

For countries using 100V, 110V, 115V and 120V AC mains, select the 115V switch position on the Voltage Selector switch.

For countries using 220V, 230V, and 240V AC mains, select the 230V switch position on the Voltage Selector switch. There is no externally accessible AC mains (line) fuse, the internal fuse is integral to the SMPS power supply and is not user serviceable. This fuse will not fail except under very unlikely fault conditions to the SMPS, and if this occurs a qualified service technician is required to correct the problem.

CHASSIS DESIGN – The SHUTTLE 6.0®’s ULTRA LIGHT DESIGN utilizes the highest quality aircraft grade, computer machined aluminum chassis. To clean the amplifier, nothing more than a damp cloth and a little bit of glass cleaner (like Windex™) should be used.

RACK MOUNTING – The SHUTTLE 6.0® is designed to be rack mounted in a standard EIA style 19” equipment rack or tour-case. Optional rack mounting kit is available from your dealer.

GIG-BAG – A custom padded carry bag with shoulder strap is available as an optional accessory from your dealer. This padded bag is ideal for convenient carrying of the amplifier. Do not operate the amplifier inside the carry bag, as the chassis aluminum construction and cooling fan inlet vents are part of the amplifier’s cooling mechanism.

COMBO VERSIONS - REMOVABLE CHASSIS FEATURE—A unique element of the SHUTTLE 6.0® combo models is the ability to easily remove the amp “head” from its protective “saddle” and use the Shuttle amp with larger enclosures for bigger venues.

Removal of the chassis is simple. We recommend first unplugging the speaker cable from the back of the chassis.



Step One:

- Unscrew the large thumbscrews on both sides of the chassis’ saddle.

- It is recommended to screw these back into the chassis after the amp is removed, so as not to loose them.



Step Two:

- After the thumbscrews are removed, gently slide the chassis forward using both hands to move it forward in the saddle.



Step Three:

- As the chassis appears from within the saddle, grab it from the front end and remove it completely from the protective saddle.

STL6.0-12T COMBO -This model produces 375 watts into the 8 ohm combo configuration and 600 watts when used with an 8 ohm extension cabinet. It will be necessary to use a Neutrik Speak-On™ connection when using an extension cabinet with this combo. The speaker is our GBE 12300, 12" Neodymium cast frame driver coupled with our GBE 4941 tweeter. A 100 watt tweeter level control is provided to adjust the output of this component.

STL6.0-210T COMBO -This larger model produces 375 watts into the 8 ohm combo configuration and 600 watts when used with an 8 ohm extension cabinet. It will be necessary to a the Neutrik Speak-On™ connection when using an extension cabinet with this combo. The combo is loaded with our GBE 10250, 10" cast frame Neodymium driver coupled with our GBE 4941 tweeter. A 100 watt tweeter level control is provided to adjust the output of this component.

BLOCK DIAGRAM

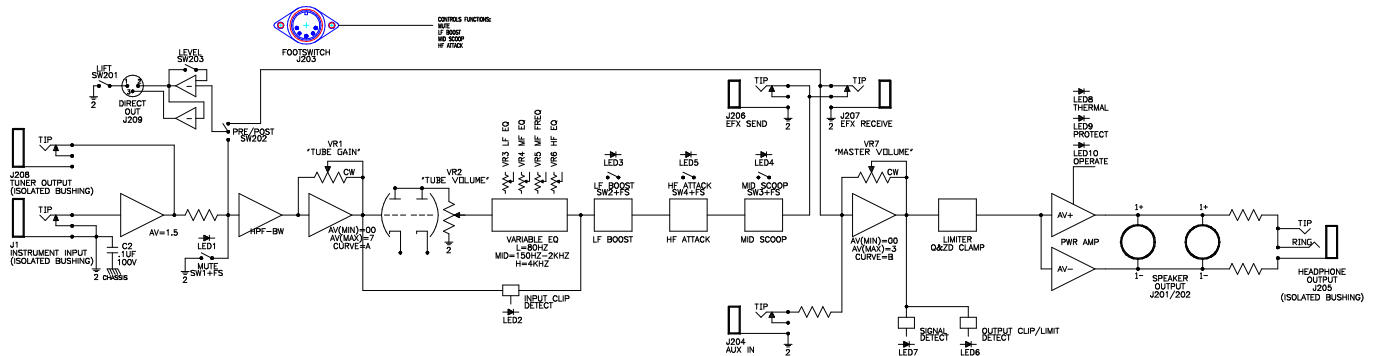

BLOCK DIAGRAM SHUTTLE 6.0

Specifications

STL6.0 (head)
 Rated Power:
 375W/8ohms; 600W/4ohms
 Dimensions:
 2.5"H X 10"W X 10.50"D
 Weight:
 3.75 LBS

STL6.0-12T
 Rated Power:
 375W/8ohms; 600W /4ohms
 Dimensions:
 21 3/4"H X 18 3/8"W X 14 1/4"D
 Weight:
 32 lbs

STL6.0-210T
 Rated Power:
 375W/8ohms; 600W 4/ohms
 Dimensions:
 27 3/4"H X 18 3/8"W X 14 1/4"D
 Weight:
 41 lbs

SAFE OPERATING REQUIREMENTS:

- Never set an amplifier on anything that will tip over or collapse under its weight.
- Provide a minimum distance of 25.4 mm (1 inch) around all sides of the amplifier for sufficient ventilation. The ventilation should not be impeded by covering the amplifier's vent openings with items such as newspapers, table-cloths, curtains, etc.
- No naked flame sources, such as lighted candles, should be placed on the Shuttle 6.0 amplifier.
- This amplifier should not be exposed to dripping or splashing and no objects filled with liquids, such as vases or drinks, should be placed on this product.
- The SHUTTLE 6.0® amplifier should be connected to a mains socket outlet (power receptacle) with a protective earth (ground) connection at all times.
- The amplifiers mains plug (power plug) is considered the disconnect device and the connection must remain accessible at all times.
- This amplifier is capable of producing sound pressure levels that may cause hearing loss.
- There are no user serviceable parts and hazardous operating voltages are present inside this unit. Always consult a qualified repair facility for service.

WARNING!

- The use and operation of this device constitutes an agreement of full release of any and all liability connected with it's use. Only persons familiar with the operation of high-powered professional audio equipment should attempt to operate this device.
- In addition, by use of this device, the user agrees to hold Genz Benz and it's designers, sales agents and all other affiliates and related parties harmless in the event of any accident, injury, damage, or loss resulting from such use.
- Manufacturer's sole responsibility is to provide a warranty on the specified performance of the product under normal operating conditions for a period of 3 years.

WARRANTY:

- Genz Benz warrants the model SHUTTLE 6.0® to be free from defects in materials and workmanship for a period of 3 years from the date of purchase, when purchased from an authorized Genz Benz dealer.
- This warranty does not cover normal wear and tear incurred from the normally designed use of the product.
- This warranty is effective only if a copy of the original sales receipt is presented at the time of warranty service
- This limited warranty is completely transferable to any subsequent buyer as long as the original sales receipt is also transferred to such subsequent buyer.
- All warranty service must be performed by a Genz Benz authorized service center.
- Before returning any unit for service, a returned merchandise authorization number (RMA#) must be obtained by calling 480-941-0705
- This warranty is valid in the US & Canada only. For all products sold outside the USA, warranty is handled through our international distributor for each country. For more information visit our website www.GENZBENZ.com

**Declaration of Conformity
(89/336 EEC-EMC Directive)**

Manufacturer's Name: Genz Benz, a division of KMC Music Corporation
 Manufacturer's Address: 7811 East Pierce Street
 Scottsdale, AZ 85257, U.S.A.

Product Type: Audio Amplifier
 Model Number: SHUTTLE 6.0® (all versions)
 Operating Power Condition: 100/115/230/240 V, 50/60 Hz
 Effective Date: 01-01-2008

Conforms to the Following Standards: EN 55013: 2001 + A1: 2003
 EN 55020: 2002 + A1: 2003
 EN 60065: 2001+A1
 IEC 61000-3.3: 1994 + A1: 2001
 IEC 61000-4.2
 IEC 61000-4.3
 IEC 61000-4.4
 FCC 15.107 and 15.109
 RoHS Directive 2002/95/EC
 WEEE Directive 2002/96/EC
 CE Mark LV Directive 73/23 EEC

GENZ·BENZ

7811 E. Pierce St. Scottsdale, AZ 85257
 Ph: 480-941-0705 Fax: 480-946-2412
www.genzbenz.com
 A KMC Music Corporation, Bloomfield, CT