

# S-Series

**Portable Linear-Response  
Loudspeaker Systems**



**Operation Manual**



## **EC STATEMENT OF CONFORMITY**

This document confirms that the range of products of Community Professional Loudspeakers bearing the CE label meet all of the requirements in the EMC directive 89/336/EEC laid down by the Member States Council for adjustment of legal requirements. Furthermore, the products comply with the rules and regulations referring to the electromagnetic compatibility of devices from 30-August-1995.

The Community Professional Loudspeaker products bearing the CE label comply with the following harmonized or national standards:

**DIN EN 55013:08-1991**

**DIN EN 55020:05-1995**

**DIN EN 55082-1:03-1993**

The authorized declaration and compatibility certification resides with the manufacturer and can be viewed upon request. The responsible manufacturer is the company:

**Community Light & Sound**  
**333 East 5<sup>th</sup> Street**  
**Chester, PA 19013**  
**USA**

**TEL: 1-610 876-3400**

**FAX: 1-610 874-0190**

Chester, PA USA February 2007

## WELCOME TO COMMUNITY!

Since 1968, Community has been designing and building innovative loudspeaker products for the worldwide sound reinforcement industry. Founded by Bruce Howze, who remains the principal designer to this day, the company has achieved numerous 'firsts' in technology breakthroughs. Some of these include:

- First** - fiberglass composite loaded midrange horn for touring systems – the LMF.
- First** - large-scale fiberglass horns used on Elvis Presley's 1971 tour.
- First** - testing and documentation of loudspeakers in a free field acoustical environment.
- First** - to publish coverage patterns of its loudspeakers, setting the industry standard.
- First** - mid-range compression driver, the M4.
- First** - carbon fiber diaphragm compression driver.
- First** - passive loudspeakers with internal multi-band, multi-level processing.
- First** - Ferrofluid-cooled professional cone drivers.
- First** - HF compression driver diaphragm without an outer suspension – the VHF100.

Community's philosophy is to build products that are uncompromised in sound quality, reliability, durability and flexibility, all at a fair price. We provide comprehensive technical support and we stand behind every product we manufacture. We pledge to do our best to insure that you are satisfied with your Community purchase!



**Community Professional Loudspeakers**  
333 East Fifth Street  
Chester, PA 19013 USA  
TEL: 1-(610) 876-3400  
FAX: 1-(610) 874-0190

©2007 All Rights Reserved

# TABLE OF CONTENTS

TABLE OF FIGURES .....	5
IMPORTANT SAFETY INFORMATION .....	5
C-TIPS .....	6
PRECAUTIONS & SAFETY CONSIDERATIONS .....	6

## S-SERIES OPERATION MANUAL

INTRODUCTION.....	7
S-SERIES FEATURES AND TECHNOLOGY .....	7
UNPACKING AND INSPECTION .....	8
<i>S-Series Specifications</i> .....	9
GETTING ACQUAINTED .....	10
<i>Physical Features Of S-Series Full-Range Models</i> .....	11
<i>Physical Features Of S-Series Subwoofers</i> .....	13
GENERAL DESCRIPTION .....	14
DYNA-TECH DRIVER PROTECTION SYSTEM.....	14
HIGH-FREQUENCY PRESENCE SWITCH.....	15
SELECTABLE HIGH-PASS OUTPUT ON SUBWOOFERS .....	16
COOL-COIL™ TECHNOLOGY .....	18
OPERATING IN PASSIVE OR BI-AMPED MODE .....	18
HIGH-PASS FILTERS .....	19
CHOOSING ACTIVE CROSSOVERS .....	19
USING PROTECTIVE LIMITERS .....	20
CONNECTING THE AMPLIFIER TO THE LOUDSPEAKER .....	22
S-SERIES APPLICATIONS .....	32
POSITIONING SUBWOOFERS .....	33
SYSTEM EQUALIZATION .....	37
RIGGING AND MOUNTING S-SERIES ENCLOSURES.....	40
S-SERIES RIGGING AND MOUNTING HARDWARE.....	47
1. <i>Seat Track Kit: STKIT</i> .....	47
2. <i>Vertical Fly Kit: VFKIT</i> .....	49
AVAILABLE ACCESSORIES .....	54
SERVICING S-SERIES LOUDSPEAKERS.....	55
TROUBLESHOOTING GUIDE .....	55
REPLACEMENT PARTS.....	57
SUMMING THINGS UP .....	57
WARRANTY INFORMATION AND SERVICE .....	58

**Notice:** Every effort was made to insure that the information contained in this manual was complete and accurate at the time of printing. However, due to ongoing technical advances, changes or modifications may have occurred that are not covered in this manual.

# TABLE OF FIGURES

Following is a list of figures found in this manual:

Figure	Title	Page
1	Physical Features of Typical S-Series Full-Range Models	10
2	Physical Features of Typical S-Series Subwoofers	12
3	Graph Depicting Frequency Response of MUSIC / VOICE Presence Switch	16
4	Graph Depicting Response of HIGH-PASS / FLAT Switch	17
5	Community's Cool-Coil™ Heat Evacuation System	18
6	S-Series Full-Range Input Panel	22
7	S-Series Subwoofer Input Panel	25
8	Single Amp Connections	26
9	Bi-amp Connections	26
10	Effect of Clipping on a Sinewave	30
11	Effect of Boundary Surfaces on Power Output	34
12	Load Angles	43
13	Never Reeve Cables!	43
14	Never Reeve Cables!	45
15	STKIT Assembly of S-Series Enclosure with four Seat Track Channels and M10 Hardware	49
16	VFKIT Vertical Fly Kit Assembly	50
17	Never Reeve Cables!	52
18	Rigging Three Enclosures with the VFKIT	52
19	Rigging Four Enclosures with the VFKIT	53

## IMPORTANT SAFETY INFORMATION

Always follow these basic safety precautions when using or installing S-Series loudspeakers and accessories:

1. Read these instructions.
2. Keep these instructions.
3. Heed all warnings.
4. Follow all instructions, particularly those pertaining to rigging, mounting, hanging and electrical connections.
5. Only use accessories that are specified and approved by the manufacturer.

The terms **CAUTION**, **WARNING**, and **DANGER** are used throughout this manual to alert the reader to important safety considerations. If you have any questions or do not understand the meaning of these terms, do not proceed with installation. Contact your local dealer, distributor, or call Community directly for assistance. These terms are defined below:



**CAUTION:** describes an operating condition or user action that may expose the equipment or user to potential damage or danger.

**WARNING:** describes an operating condition or user action that will likely cause damage to the equipment or injury to the user or to others in the vicinity.

**DANGER:** describes an operating condition or user action that will immediately damage the equipment and/or be extremely dangerous or life threatening to the user or to others in the vicinity.

## C-TIPS



Occasionally, in this manual, you'll come across some useful tips that are intended to help you get the most from your use of S-Series loudspeakers in portable applications and fixed installations. We call these **C-TIPS** (short for COMMUNITY-TIPS or COOL-TIPS...we'll let you decide!). These tips originate from Community staff members as well as from installers and end users. We welcome any C-TIPS that you may want to share with us, and we'll acknowledge you as the source if we print them in future user's manuals.

## PRECAUTIONS & SAFETY CONSIDERATIONS

### English

The loudspeakers described in this manual are designed and intended to be 'flown' or suspended for maximum acoustical performance using a variety of rigging hardware, means, and methods. It is essential that all installation work involving the suspension of these loudspeaker products be performed by competent, knowledgeable persons who understand safe rigging practices. Severe injury and/or loss of life may occur if these products are improperly installed. Please read the section on rigging for additional information.

### Français

Les haut-parleurs décrits dans ce manuel sont conçus et sont projetés pour être 'volé' ou suspendu pour l'exécution acoustique maximum utilisant une assortiment d'équiper matériel, les moyens, et les méthodes. C'est essentiel que tout travail d'installation ait impliqué la suspension de ces produits d'haut-parleur est exécutée par les personnes compétentes et entraînées qui comprennent équiper les pratiques sûres. La perte sévère de et/ou de blessure de vie peut arriver si ces produits sont incorrectement installés. S'il vous plaît lire la section d'équiper pour l'information supplémentaire.

### Deutsch

Die Lautsprecher, die in diesem Handbuch beschrieben werden, sind entworfen und sind zu sein 'geflogen' vorgehabt oder sind für maximale hörbare Leistung verschiedene Manipulierenhardware, Mittel, und Methoden suspendiert benutzend. Es ist wesentlich, dass alle Installationarbeit, die die Aufhängung von diesen Lautsprechernprodukten verwickelt, von fähigen, ausgebildeten Personen durchgeführt werde, die sichere Manipulierenpraxis verstehen. Schwere Verletzung bzw. Verlust des Lebens können stattfinden, wenn diese Produkte unrichtig installiert sind. Bitte lesen Sie den Abschnitt über Manipulieren für zusätzliche Informationen.

### Italiano

Gli altoparlanti descritti in questo manuale sono disegnati e sono intesi essere 'volato' o sospeso per la prestazione massima acustica usando una varietà di attrezzature di hardware, i mezzi, ed i metodi. È essenziale che tutta il lavoro di installazione coinvolgendo la sospensione di questi prodotti di altoparlante è eseguita da dalle persone competenti, addestrate che capisce le pratiche di attrezzature di cassaforte. La lesione severa e/o la perdita di vita possono accadere se questi prodotti sono erratamente installati. Per favore di leggere la sezione di attrezzature per le ulteriori informazioni.

### Español

Los altavoces descritos en este manual se diseñan y son pensados ser 'volado' o suspendido para el desempeño acústico máximo que utiliza una variedad de aparejar hardware, de medios, y de los métodos. Es esencial que todo trabajo de la instalación que implique la suspensión de estos productos del altavoz sea realizado por personas competentes y entrenada que entienden aparejar seguro las prácticas. La herida y/o la pérdida severas de la vida pueden ocurrir si estos productos se instalan impropriamente. Lea por favor la sección a aparejar para la información adicional.

# S-SERIES OPERATION MANUAL

## INTRODUCTION

Thank you for selecting Community's S-Series. S-Series is a family of affordable, linear-response loudspeakers designed for use in applications requiring controlled coverage patterns, high-impact power response, with clear and intelligible sonic output. All models are designed with portability in mind, but they are equally effective in permanent or semi-permanent installations.

The S-Series family of products is well suited for use in nightclubs, cafes, discotheques, houses of worship, auditoriums, meeting rooms, theatres, outdoor concerts, and most anywhere else that people gather to enjoy music and hear the spoken word.

S-Series loudspeakers are flexible, easy to set up and use, and most importantly they provide superb sound quality.

This Operation Manual is intended to help you use S-Series loudspeakers effectively and safely. It provides useful information to assist you in obtaining the best performance, sound quality, and reliability from your S-Series products.

We've provided several easy-to-understand diagrams to enable you to operate your S-Series loudspeakers immediately if required; however, we recommend that you read the entire manual to insure that your use of S-Series for shows, events, and installations meet the highest possible standards.

## S-SERIES FEATURES AND TECHNOLOGY

S-Series loudspeakers offer numerous features and advances in technology that provide superb sound and long-term reliability. Some of these include:

- Sophisticated internal crossover networks for reduced off-axis lobing and consistent coverage throughout the crossover region.
- Selectable crossover modes (*bi-amped* or passive *single-amped*).
- Carbon Ring Cone Technology; used on all full-range low-frequency drivers for reduced distortion, enhanced transient response, and 30% greater cone area than conventional cone drivers (patent pending).
- Ferrofluid-cooled high-frequency and mid-frequency drivers for improved heat conductance and dramatically reduced distortion through viscous damping of driver resonant modes.
- Music / Speech **PRESENCE** Switch re-voices the loudspeaker's tonal balance for increased articulation in the vocal range.
- Powerful 1-inch-throat high-frequency compression drivers offer extended high-end response, smooth output, and lower distortion than larger format drivers.
- Non-metallic high-frequency diaphragms provide a further reduction in distortion by eliminating the mechanical resonance normally associated with brittle metallic materials.
- Geometrically correct, hand-laid fiberglass mid and high-frequency waveguides.
- Community's patented Cool-Coil™ *heat evacuation technology* minimizes cone driver power compression and ensures long-term reliability (used in subwoofers).

- DYNA-TECH™ active protection circuitry aids in reducing the likelihood of damage under abusive conditions.
- Switchable high-pass output on subwoofers maximizes performance when a full-range system and a subwoofer are powered by a single amplifier channel.
- Rugged 11-ply cross-laminated Birch enclosures, coated with a two-part catalyzed polyester paint for durability.
- Protective steel grilles covered with durable powder-coat finish.
- Load rated M10 fly points on tops, bottoms and rear of enclosures for safe & easy rigging (note: M10 fly points are located on the end panels of the subwoofers).
- Dual NL4-compatible locking connectors, plus dual ¼" jacks allow easy connectivity with readily available cables.
- Factory designed rigging hardware available from stock.

## UNPACKING AND INSPECTION

S-Series loudspeakers are inherently rugged and are carefully packed in sturdy cartons. However, it's wise to thoroughly inspect each unit after it has been removed from the packaging, as damage could occur during shipping.

Please note that once the shipment has left your dealer or the Community factory, the responsibility for damage is *always* borne by the freight company. If damage has occurred during shipping, you must file a claim directly with the freight company. It's very important to contact the freight company as soon as possible after receiving your shipment, as most freight companies have a short time limit within which they will investigate claims. Make sure to save the carton and the packing material, as most claims will be denied if these materials are not retained. Your Community dealer and the factory will try to help in any way they can, but it is the responsibility of the party receiving the shipment to file the damage claim.

It's always a good idea to retain the carton and packing materials indefinitely, if possible, in the event that the unit may need to be returned to your dealer or distributor for repair in the future.

Each shipping carton contains the following items:

- Loudspeaker System (Qty 1)
- Operation Manual (Qty 1)
- Warranty Card (Qty 1)



**DANGER:** S-Series rigging fittings are each rated at a Working Load Limit (WLL) of 100 lbs (45.4kg) with a 10:1 safety margin. No single rigging fitting should ever be subjected to a load that is greater than this stated limit. Failure to heed this warning could result in injury or death!



**IMPORTANT:** The flat-head Allen-drive rigging screws that come installed in each enclosure must either be replaced with rigging brackets and threaded fasteners, or they must be kept in place to seal the enclosure from air leaks. If the rigging fittings do not remain sealed, air leaks will occur in the enclosure that will compromise the low-frequency performance with distortion and reduced output.



## S-Series Specifications

Model	S-1296	S-1596	S-3294	S-3594	S-215S	S-218S	
<b>Loudspeaker Type</b>	Two-way, full-range, vented bass - switchable passive or bi-amp	Two-way, full-range, vented bass - switchable passive or bi-amp	Three-way, full-range, vented bass - switchable passive or bi-amp	Three-way, full-range, vented bass - switchable passive or bi-amp	Dual driver subwoofer, vented bass - switchable hi-pass/parallel output	Dual driver subwoofer, vented bass - switchable hi-pass/parallel output	
<b>Driver Complement</b>	LF: 1 x 12"	LF: 1 x 15"	LF: 1 x 12"	LF: 1 x 15"	LF: 2 x 15"	LF: 2 x 18"	
	HF: 1 x 1"	HF: 1 x 1"	MF: 1 x 6.5"	MF: 1 x 6.5"			
<b>Nominal Dispersion (H x V)</b>	90° x 60°	90° x 60°	90° x 40°	90° x 40°	360° x 180°	360° x 180°	
<b>Operating Range</b>	60 Hz - 20 kHz	50 Hz - 20 kHz	60 Hz - 20 kHz	55 Hz - 20 kHz	30 Hz - 2 kHz	30 Hz - 1 kHz	
<b>Frequency Response</b>	100 Hz - 16 kHz	90 Hz - 16 kHz	90 Hz - 16 kHz	80 Hz - 16 kHz	40 Hz - 200 Hz	40 Hz - 200 Hz	
<b>Max Input Ratings (passive mode)</b>	200W RMS (40V)	200W RMS (40V)	200W RMS (40V)	200WRMS (40V)	400W RMS (40V)	600W RMS (49V)	
	500W PGM	500W PGM	500W PGM	500W PGM	1000W PGM	1500W PGM	
	990W PEAK	990W PEAK	990W PEAK	990W PEAK	1980W PEAK	2970W PEAK	
<b>Sensitivity 1W/1m</b>	99 dB SPL	102 dB SPL	100 dB SPL	101 dB SPL	97 dB SPL*	100 dB SPL*	
<b>Maximum SPL</b>	122 dB cont. 129 dB peak	124 dB cont. 131 dB peak	123 dB cont. 130 dB peak	123 dB cont. 130 dB peak	120 dB cont. 127 dB peak	125 dB cont. 132 dB peak	
<b>Nominal Impedance</b>	8 Ohms	8 Ohms	8 Ohms	8 Ohms	4 Ohms	4 Ohms	
<b>Input Connection</b>	Dual NL4 with dual ¼" jacks in parallel	Dual NL4 with dual ¼" jacks in parallel	Dual NL4 with dual ¼" jacks in parallel	Dual NL4 with dual ¼" jacks in parallel	Dual NL4 with dual ¼" jacks in parallel	Dual NL4 with dual ¼" jacks in parallel	
<b>Rigging Provisions</b>	Eight M10 threaded rigging fittings - three each on top and bottom; two on rear	Ten M10 threaded rigging fittings - four each on top and bottom; two on rear	Ten M10 threaded rigging fittings - four each on top and bottom; two on rear	Ten M10 threaded rigging fittings - four each on top and bottom; two on rear	Eight M10 threaded rigging fittings - four on each end of enclosure	Four M10 threaded rigging fittings - two on each end of enclosure	
<b>Construction</b>	11 ply cross-laminated birch	11 ply cross-laminated birch	11 ply cross-laminated birch	11 ply cross-laminated birch	11 ply cross-laminated birch	11 ply cross-laminated birch	
<b>Finish</b>	Black catalyzed polyester two-part paint	Black catalyzed polyester two-part paint	Black catalyzed polyester two-part paint	Black catalyzed polyester two-part paint	Black catalyzed polyester two-part paint	Black catalyzed polyester two-part paint	
<b>Dimensions</b>	<b>H</b>	23.9 in / 607mm	27.2 in / 691mm	29.3 in / 744mm	32.4 in / 823mm	18.4 in / 467mm	21.4 in / 544mm
	<b>(in / mm) W</b>	14.9 in / 378mm	18.4 in / 467mm	17.4 in / 442mm	18.4 in / 467mm	37.4in / 950mm	44.4 in / 1128mm
	<b>D</b>	13.4 in / 340mm	15.9 in / 404mm	15.4 in / 391mm	15.9 in / 404mm	20.4 in / 518mm	24 in / 610mm
<b>Weight (lbs / kg)</b>	36lbs / 16.3kg	46.5lbs / 21.1kg	53lbs / 24kg	58lbs / 26.3kg	89lbs / 40.4kg	127lbs / 57.6kg	

Due to ongoing development, specifications are subject to change without notice.

Note: \*denotes half-space sensitivity.

# GETTING ACQUAINTED

**Figure 1: Physical Features of Typical S-Series Full-Range Models**

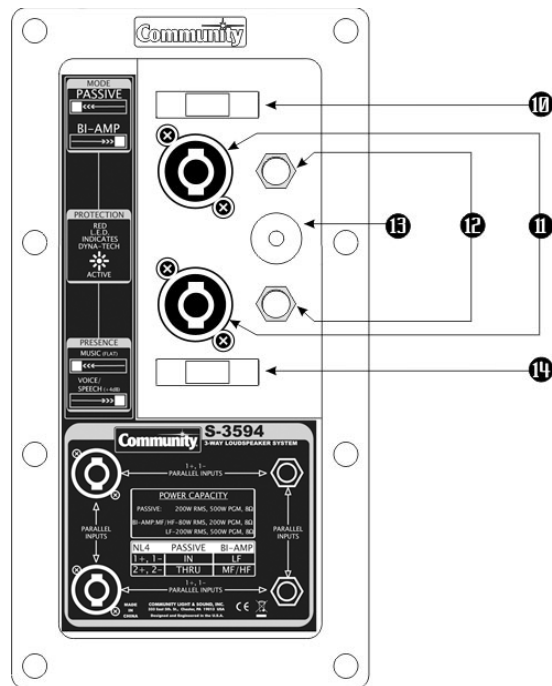
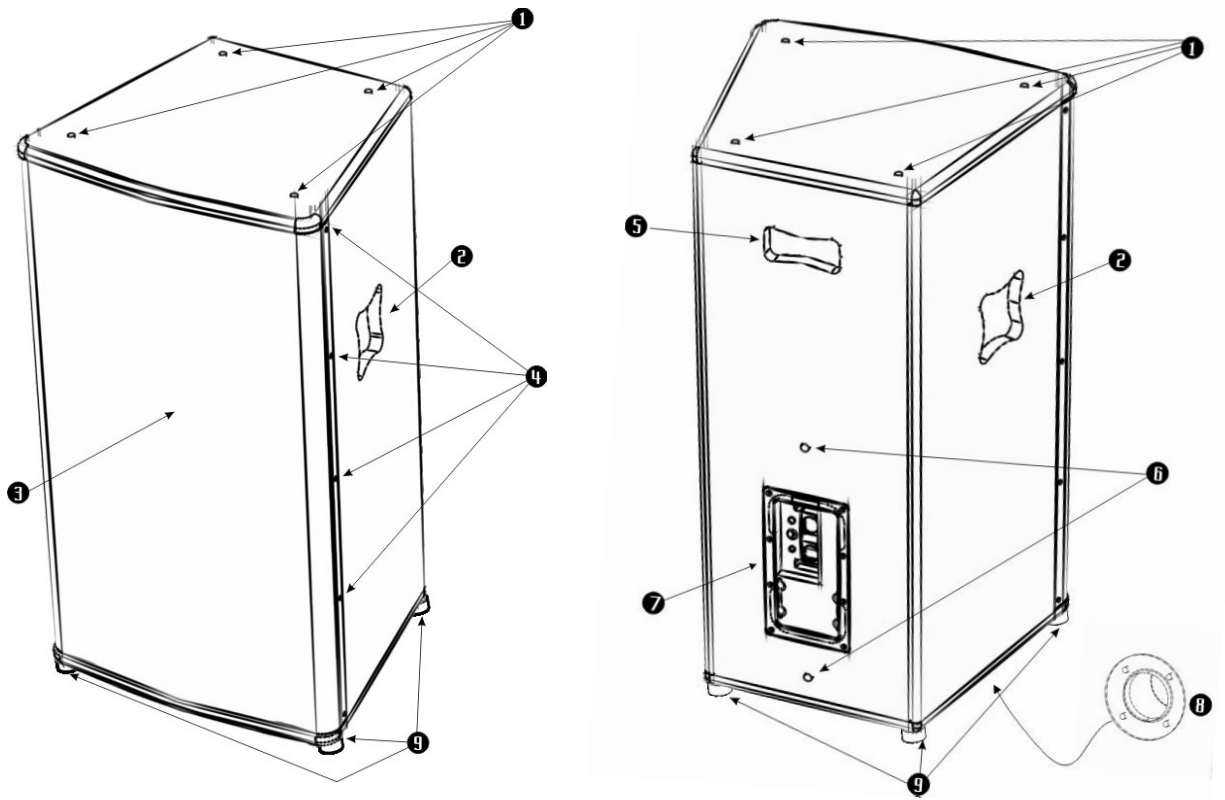

**S-Series Full-Range Input Panel**

## PHYSICAL FEATURES OF S-SERIES FULL-RANGE MODELS

FEATURE	DESCRIPTION
1	TOP & BOTTOM RIGGING POINTS 8 total, 4 top and 4 bottom - bottom points not shown <sup>1</sup> (note: S-SERIES-1296 has 3 top and 3 bottom).
2	ERGO-GRIP SIDE LIFTING HANDLES 2 total.
3	PROTECTIVE GRILLE Powder-coated steel grille protects drivers from foreign objects.
4	GRILLE RETENTION SCREWS Eight (or ten) #6 x 5/8" sheet metal screws, depending on model.
5	REAR ERGO-GRIP LIFTING HANDLE 1 total.
6	REAR PULL-BACK POINTS Used for angling enclosure downward; not for primary rigging.
7	INPUT PANEL For amplifier connection to the loudspeaker. Also contains <i>Bi-amp / Single-amp</i> switch, <i>Presence</i> switch, and DYNA-TECH™ Protection Indicator.
8	POLE SUPPORT RECEPTACLE Installed on bottom of enclosure. Accepts standard loudspeaker support pole (1.375" / 35 mm diameter).
9	FEET 4 synthetic-rubber feet protect surfaces from marring.
10	PASSIVE / BI-AMP SWITCH Used to select loudspeaker's operating mode. <b>LEFT</b> position is for PASSIVE mode (single amplifier) and <b>RIGHT</b> position is for BI-AMPLIFIED mode (separate LF and HF amplifiers).
11	NL4-COMPATIBLE LOCKING CONNECTORS Two 4-pole NL4MP type loudspeaker connectors wired in parallel. Accepts NL4FC connectors. Used for both PASSIVE and BI-AMPLIFIED modes. Use terminals #1 +/- for PASSIVE mode or for BI-AMPLIFIED LF input. Use terminals #2 +/- for BI-AMPLIFIED HF input (not used in PASSIVE mode).
12	¼" JACKS Wired in parallel with Pins #1+ and #1- of both NL4MP connectors. Note: may only be used in PASSIVE mode.
13	DYNA-TECH™ PROTECTION INDICATOR Red LED indicates that DYNA-TECH active protection circuits have been engaged, reducing the potential of driver damage.
14	PRESENCE SWITCH Selects between MUSIC (Flat) and VOICE/ SPEECH (+4dB) operating modes (LEFT position is MUSIC (Flat), RIGHT is VOICE/SPEECH). Re-voices the loudspeaker's tonal balance for increased articulation in the vocal range.

<sup>1</sup> 100 lbs (45.4 kg) Working Load Limit / 10:1 safety factor

**Figure 2: Physical Features of Typical S-Series Subwoofers**

(Note: the S-215S Subwoofer is not equipped with wheels)

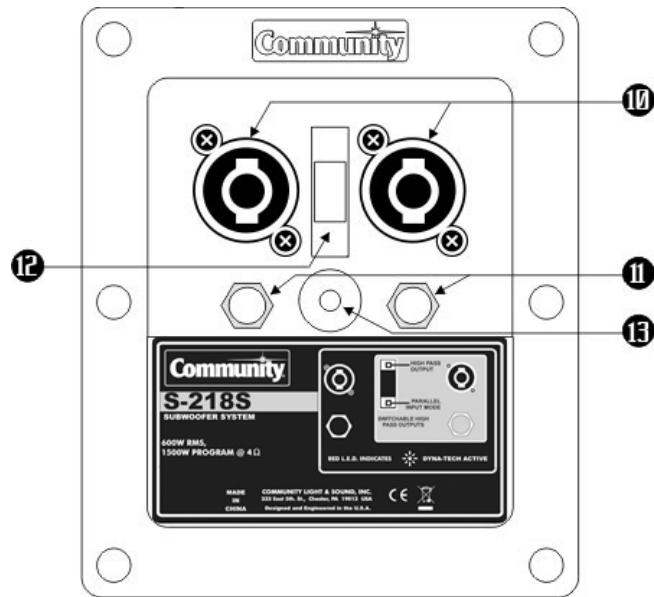
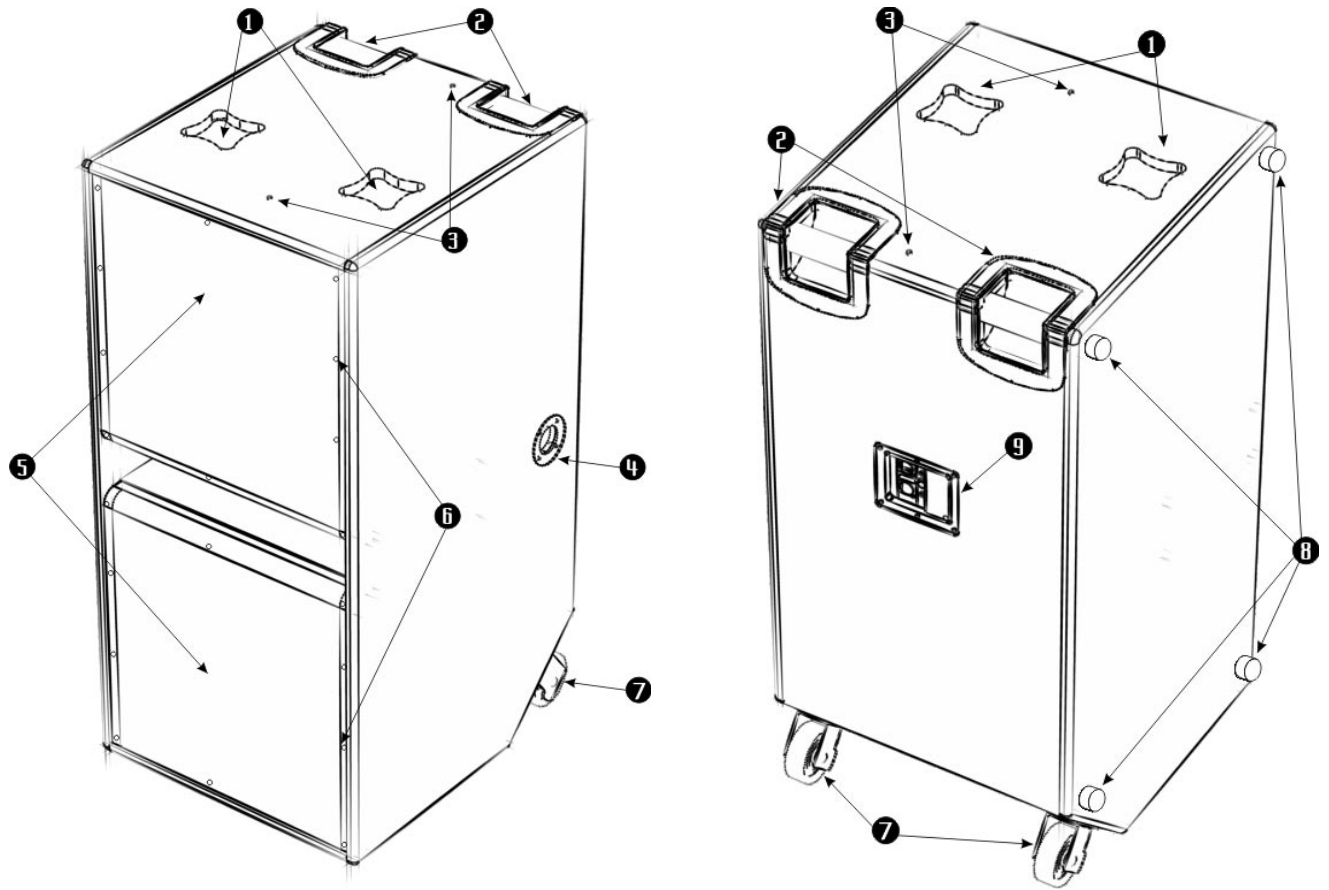

**S-Series Subwoofer Input Panel**

## PHYSICAL FEATURES OF S-SERIES SUBWOOFERS

FEATURE	DESCRIPTION
1	LIFTING HANDLES 4 total; 2 on each end panel.
2	'HANDTRUCK' HANDLES 2 total. For tilting the enclosure onto its built-in transport wheels ( <i>model 218S only</i> ).
3	RIGGING POINTS MODEL S-218S: 4 total; 2 on each end panel <sup>2</sup> . MODEL S-215S: 8 total; 4 on each end panel <sup>3</sup> .
4	POLE SUPPORT RECEPTACLE Installed on top of enclosure. Accepts standard loudspeaker support pole (1.375" / 35 mm diameter). Receptacle is sleeved to the bottom of the enclosure for maximum stability.
5	PROTECTIVE GRILLE Powder-coated steel protects drivers from foreign objects.
6	GRILLE RETENTION SCREWS Twenty #6 x 5/8" sheet metal screws.
7	INTEGRATED TRANSPORT WHEELS Dual permanently mounted rigid casters (non-swivel), for easy transport ( <i>model 218S only</i> ).
8	FEET 4 synthetic-rubber feet protect surfaces from marring.
9	INPUT PANEL For amplifier connection to the loudspeaker. Also contains FLAT / HI-PASS Switch and DYNA-TECH protection indicator.
10	NL4-COMPATIBLE LOCKING CONNECTORS 4-pole NL4MP type loudspeaker connectors, wired in parallel. Accepts NL4FC connectors. Use terminals #1 +/-. Terminals #2 +/- are wired in parallel with #1 +/-.
11	¼" JACKS Permanently wired in parallel to Pins #1+ and #1- on the NL4 closest to the ¼" jack.
12	HIGH-PASS SWITCH Selects between HI-PASS OUTPUT and PARALLEL INPUT MODE on the speaker output connectors (up is HI-PASS, down is PARALLEL). HI-PASS filter is 125 Hz, 6/dB per octave with an 8Ω load (note: crossover frequency is load dependent).
13	DYNA-TECH PROTECTION INDICATOR Red LED indicates that DYNA-TECH active protection circuits have been engaged, reducing the potential of driver damage.

<sup>2</sup> 100 lbs (45.4 kg) Working Load Limit / 10:1 safety factor

<sup>3</sup> 100 lbs (45.4 kg) Working Load Limit / 10:1 safety factor

# GENERAL DESCRIPTION

S-Series loudspeakers are designed for demanding day-to-day use in a wide range of both portable applications and fixed installations. Their high quality driver components are housed in rugged, acoustically inert enclosures fitted with convenient carrying handles, rigging fittings, and support stand receptacles. S-Series is characterized by a high-power, low distortion linear response that provides exceptional musicality and speech intelligibility.

The S-Series consists of six models:

- **S-1296** - a 12" / 1" two-way, in a multi-angle enclosure suitable for FOH or Stage Monitoring.
- **S-3294** - a 12" / 1" three-way which includes the addition of a horn-loaded 6.5" cone driver, in a trapezoidal enclosure.
- **S-1596** - a 15" / 1" two-way, in a trapezoidal enclosure.
- **S-3594** - a 15" / 1" three-way which includes the addition of a horn-loaded 6.5" cone driver, in a trapezoidal enclosure.
- **S-215S** - a dual 15" subwoofer, in a rectangular enclosure.
- **S-218S** - a dual 18" subwoofer, in a rectangular enclosure with integrated casters.

**Note: All models have integrated support stand fittings.**

When used in multiples, S-Series loudspeakers array well. Systems may be designed around horizontal splayed arrays, vertical splayed arrays, as well as exploded clusters and distributed configurations. Rigging kits are available from the factory as standard items (see the section on Rigging Hardware on page 46).

The specifications table on page 9 depicts dimensions, weights and general specifications of the various S-Series models.

## DYNA-TECH DRIVER PROTECTION SYSTEM

All S-Series loudspeakers employ Community's advanced technology DYNA-TECH driver protection system. Functioning as a multi-stage limiter, DYNA-TECH circuitry provides precise and repeatable protection by reducing excessive power to the drivers under abusive conditions.

The first stage of limiting is designed to protect against short-term excess power applied to the high-frequency driver(s) in the system. This circuit utilizes an HPCCR (High Positive Current Coefficient Resistor) in series with the driver(s). The HPCCR increases resistance as the current flowing through it increases. As its resistance rises above nominal, the heating of the element provides RMS conversion. The result is an RMS limiter with a ratio that varies according to the demands of the program material.

The second stage of limiting protects against excessive power levels to *all* drivers in the system. This stage is based on a relay driven through a voltage sensing circuit. The relay engages at a pre-determined voltage, corresponding to a power level that would otherwise cause driver damage. When engaged, the relay introduces a bank of high-wattage resistors in series with the drivers. These resistors cause a voltage drop to the drivers, thereby reducing the power applied to them. A red LED on the rear panel indicates that this protection circuit has been engaged.

When the relay protection circuit is activated, there will be a noticeable drop in the system's level (approximately 3 to 4 dB). The red LED, as well as the drop in level, serves as a warning to the operator that the loudspeaker is being overdriven. ***When this stage of protection is engaged, the level of console and/or amplifier output to the system should be reduced.***



**IMPORTANT:** If the operator continues to run the system at excessive levels, or worse, if the operator raises the drive level to compensate for the drop in output caused by the protection circuitry, eventually an additional stage of protection will engage that shuts down the system entirely (note that this additional stage of protection will never engage until *after* the second stage has been triggered). If the system shuts down entirely, the operator can immediately restore sound by merely reducing the drive level to the system.

## Advantages of Community's DYNA-TECH Circuitry

There are numerous advantages to this type of multi-stage protection circuitry. The trip point is pre-set to engage at exactly the same time on all speakers that are powered from the same amplifier. The initial stages of DYNA-TECH protection circuitry do not rely on, and are not affected by heat build-up. Some manufacturers use circuit breakers that require heat build-up before they trip; this limits their ability to protect a cold speaker. The trip points of such breakers are also affected by ambient temperature, their own internal heating curves, and small variations in speaker impedance or crossover component tolerances, all of which can cause unpredictable behavior.

Because the first and second stages of Community's DYNA-TECH circuits are not thermally sensitive, they react nearly instantaneously to protect against excessive increases in level. Moreover, the protection disengages almost immediately when the level is reduced; it is not necessary to wait for a circuit breaker to cool down. This means that your loudspeaker can operate at its full dynamic range and still react quickly to excessive musical peaks, without fear of damaging the system. It also means that your loudspeaker is protected from the moment the power amplifier is plugged in and turned on, regardless of the ambient temperature.

As mentioned above, the protection circuitry provides an additional level of protection for the entire loudspeaker to guard it from severe misuse. If the system is operated in the second-stage protection mode for a long period of time, or if the input level is increased by someone trying to overcome the volume drop from the second-stage protection circuit, a solid-state circuit breaker will trip and remove all signal from the loudspeaker until the input level is reduced. Because this circuit breaker *is* heat sensitive, it provides a final level of protection that takes heat into account as well as power. However, unlike most implementations of circuit breakers that take time to cool down before resetting, DYNA-TECH circuits respond instantly to a reduction in level, restoring the system to its full dynamic range without needing to wait for the circuit breaker to reset itself.

## HIGH-FREQUENCY PRESENCE SWITCH

Each S-Series full-range loudspeaker is equipped with a **Presence Switch** on its rear input panel. This switch selects between two different high-frequency contours to adjust the voicing of the loudspeaker. Using the **Presence Switch** allows you to optimize the audio quality for different performers, for varying types of program material, and for differing acoustical environments.

One position of the Presence Switch is labeled **MUSIC (FLAT)** while the other position is labeled **VOICE-SPEECH (+4dB)**. In the **MUSIC (Flat)** position, the response of the system is essentially flat; in other words it will exhibit no significant variation in amplitude throughout its operating range. In the **VOICE-SPEECH (+4dB)** position, the mid band between approximately 2 – 4.5 kHz is accentuated by approximately +4dB for increased articulation in the vocal range, with less accentuation extending from approximately 1 kHz to 8 kHz.

**Figure 3: Graph Depicting Frequency Response of MUSIC / VOICE Presence Switch** (Note: the Voice/Speech position is represented by the dotted line)

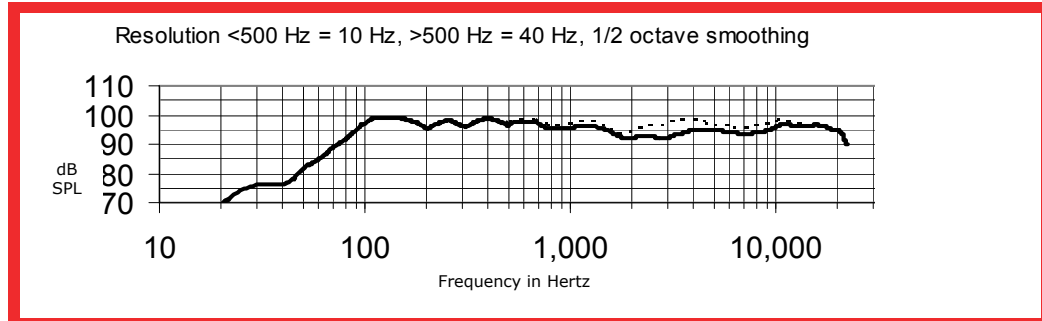

**C-TIP:** The **VOICE-SPEECH (+4dB)** position may be useful when trying to compensate for absorption loss over very long distances, or just when some additional presence is needed to achieve the tonal quality you're seeking. Note: This switch is active in both the **PASSIVE** and **BI-AMP** modes.

## SELECTABLE HIGH-PASS OUTPUT ON SUBWOOFERS

S-Series subwoofers are equipped with an industry-standard NL4-compatible locking connector wired in parallel with a 1/4" jack. A second NL4-compatible locking connector is provided, also wired in parallel to a 1/4" jack. This second set of connectors is intended as **OUTPUTS** and are associated with the subwoofer's **SWITCHABLE HIGH-PASS OUTPUT**.

When the selector switch is set to the **PARALLEL INPUT MODE** (the *down* position), both the NL4-compatible locking connector and the 1/4" jack function exactly as loop-thru connectors; in other words they are simply wired in parallel with the **INPUT CONNECTORS**.

Conversely, when the selector switch is set to **HIGH-PASS OUTPUT** (the *up* position), a 1<sup>st</sup> order high-pass filter (6 dB per octave) is inserted into the circuit. The filter has a corner frequency of 125 Hz with an 8 ohm load.

Using the **HIGH-PASS OUTPUT MODE** inserts the **HIGH-PASS FILTER** as mentioned above, but it also presents a higher impedance load to the amplifier. This can become quite important, particularly if a pair of full-range loudspeakers and a subwoofer are being powered from a single amplifier channel. In the **PARALLEL INPUT MODE**, the impedance of the combined load could become dangerously low for some amplifiers, potentially causing the amplifier to shutdown or fail.

The following graph shows the difference in the total load impedance with the high-pass switch in the **HIGH-PASS** and **PARALLEL INPUT MODE** positions. The lower line depicts the response with the switch in the **FLAT** position where the load drops below 2 ohms between 30 – 50 Hz and again between 100 – 200 Hz, potentially causing early clipping, amplifier shutdown, or even amplifier failure. The upper line depicts the response with the switch in the **HIGH-PASS** position, where the load impedance has been *increased* by about 50% by the subwoofer's internal crossover circuit, thereby protecting the amplifier from premature clipping and potential failure.



**Figure 4: Graph Depicting Response of HIGH-PASS / FLAT Switch**

(Note: upper line depicts HIGH-PASS; lower line depicts FLAT)

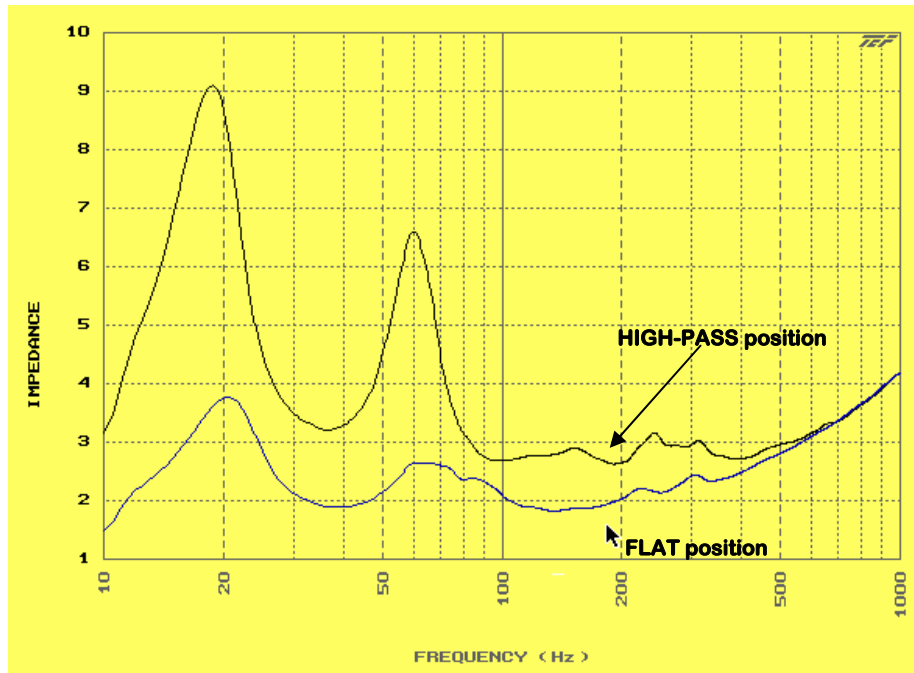

In addition to presenting a more amplifier-friendly load, the **HIGH-PASS OUTPUT** also attenuates the low-frequency energy that's fed to the full-range loudspeaker. This reduces the demand on the full-range loudspeaker's woofer, thereby freeing up some additional power and headroom in the upper part of the bass spectrum. Use of the **HIGH-PASS OUTPUT** will typically result in an overall flatter response, but with slightly less total power available in the mid-bass portion of the audio spectrum.

The results you achieve will be strongly influenced by the relative locations of the full-range loudspeaker(s) and the subwoofer(s), their position in relation to the walls, floor or ceiling, as well as the overall room acoustics. For example, if a full-range model is stacked on a subwoofer, the combined response will be different than if it is flown 15 or 20 feet over the subwoofer. We encourage you to experiment to obtain the quality of sound that is to your liking.



**IMPORTANT:** The corner frequency of the **HIGH-PASS FILTER** is load dependent (this is the case with *all* passive filters). This means that the frequency will alter if the impedance of the load changes. For example, if two 8 ohm full-range enclosures are connected to the high-pass output in parallel, the resultant 4 ohm load will change the high-pass corner frequency to 250 Hz.



**C-TIP:** For exact control in balancing the relative levels of the subwoofer(s) and the full-range loudspeaker(s), we recommend that separate amplifier channels be employed to power each unit individually. Moreover, if an electronic active crossover is used to divide the signal to the subwoofer(s) and the full-range loudspeaker(s), this will result in bi-amping the two systems. Bi-amping provides the benefit of reducing the overall power demand on each amplifier channel while reducing intermodulation distortion.

# COOL-COIL™ TECHNOLOGY

The cone drivers used in the S-Series subwoofers utilize Community's patented Cool-Coil™ heat evacuation technology. A proprietary process, Cool-Coil employs an airflow director to remove heat from the voice coil, thereby increasing both the performance and reliability of the cone drivers. In particular, the effect of Power Compression is significantly improved by Cool-Coil technology. Power Compression occurs when drivers respond non-linearly to applied power, producing less and less output as their voice coils heat up and their impedance rises.

High voice coil temperatures have other undesirable effects on performance. Most materials used in drivers, particularly adhesives and insulation, suffer some diminished properties under extremes of heat. Thermal expansion can result in warpage and misalignment of components. A voice coil in which the diameter has increased due to thermal expansion will often no longer be round, and certainly has a greater possibility of rubbing against the magnetic structure.

Any amount of cooling that can be applied to a woofer will be beneficial. One very commonly used cooling method is venting of the pole piece of the magnet structure. The motion of the cone assembly will pump air in and out of the cavity under the dust cap. This air passing through the pole vent helps to cool the magnet structure. Community has improved on this common cooling method by introducing an airflow director (US patent 6,390,231) into the air path. Figure 5 shows a conventional woofer motor with a vented pole piece, and also a similar motor with the addition of an airflow director. The voice coil former in the airflow motor is aluminum, and is taller than normal. This extended aluminum former becomes a cooling fin for the voice coil, and the airflow director causes the air to pass in close proximity to the former. By directing the air to flow over the hot aluminum former, more heat is removed from the voice coil than simply allowing the pumped air to take its natural path in and out of the cavity. This results in woofers that can handle higher power with greater reliability than those of conventional design.

**Figure 5: Community's Cool-Coil™ Heat Evacuation System**

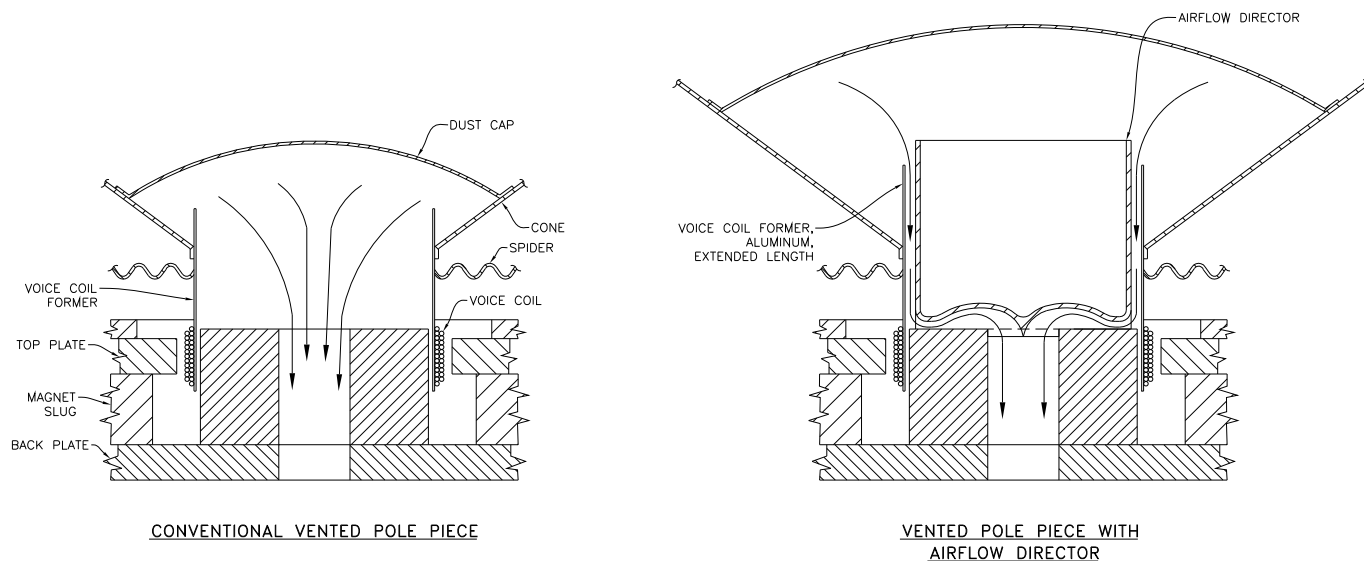

## OPERATING IN PASSIVE OR BI-AMPED MODE

All S-Series full-range loudspeaker models may be operated in either the *passive* mode or the *bi-amped* mode.

A switch on the full-range loudspeaker input panel selects between the two operating modes: PASSIVE mode (single amplifier) or BI-AMP mode (separate low and high frequency amplifiers). In both PASSIVE and BIAMP mode, the internal crossover divides the audio signal into the separate frequency ranges for each of the drivers.

In PASSIVE mode one amplifier is used to power the entire loudspeaker. In BI-AMP mode one amplifier is used to power the low frequency section and another is used to power the high frequency section. The separation of high and low frequencies is done internally in the loudspeaker, so no electronic crossover is required. Simply run full-range signals into the amplifiers and connect the outputs to the appropriate HF and LF terminals on one of the Neutrik input jacks. Use the amplifier input level controls to balance the HF to LF acoustic outputs.

Alternatively, an electronic crossover can be used before the amplifiers in the signal chain to optimize the bandwidth of audio supplied to the amplifiers. This would prevent, for example, the high-frequency amplifier from being burdened with full-range (including low frequency) content. Use of an electronic crossover can be helpful but is not necessary.



**CAUTION:** A system set up for either the *passive* or *bi-amp* mode of operation should **never** be switched to the opposite mode without first appropriately re-wiring the system! Damage to the high-frequency driver could readily occur. At best, the system will not sound or perform properly. ***Make sure to always disconnect the amplifier and re-configure the wiring before changing from one mode of operation to the other.***



**C-TIP:** *Bi-amping will almost always result in cleaner, more faithful reproduction of the program content, particularly noticeable at high levels or when reproducing complex, full-range material. If the budget permits, we recommend bi-amping as the best solution.*

## HIGH-PASS FILTERS

When operating in either the passive or the bi-amplified mode, we strongly recommend the use of an external, active high-pass filter to protect the cone drivers from excessive low-frequency excursion. High-pass filters will eliminate the potential of low-frequency modulation from wind noise, turntable rumble, stage vibration, and other causes that result in a poorly defined and 'muddy' bass response. Additionally, a high-pass filter will avoid wasting amplifier power by stopping the amplifier from attempting to reproduce frequencies below the loudspeaker's intended operating range.

The table below shows the recommended filter settings:

Model	High-Pass Filter
S-1296 Full-Range:	60 Hz, 24db/octave
S-1596 Full-Range:	50 Hz, 24db/octave
S-3294 Full-Range:	60 Hz, 24db/octave
S-3594 Full-Range:	55 Hz, 24dB/octave
S-215S Subwoofer:	30 Hz, 24db/octave
S-218S Subwoofer:	30 Hz, 24db/octave

## CHOOSING ACTIVE CROSSOVERS

A wide variety of active crossovers and loudspeaker control systems are available from numerous manufacturers. Most of today's products use DSP (Digital Signal Processing) to divide the frequency bands and provide equalization, protective limiting, and signal delay. The use of a good quality DSP processor or 'loudspeaker management tool' as many such devices are often referred to, is strongly encouraged. When properly utilized, a DSP processor provides numerous benefits that contribute to better quality sound and longer system life. Please contact Community or your Community dealer for up-to-date recommendations regarding specific types and models of available DSP products.

# USING PROTECTIVE LIMITERS

Although S-Series loudspeaker systems are well protected against potentially abusive operating conditions by their internal DYNA-TECH protection circuits, the use of an active, outboard limiter can add an extra measure of insurance for long-term reliability. Additionally, an active outboard limiter can be adjusted to provide a subtler degree of driver protection, precisely tailored to each user's specific needs in terms of musical styles and operating conditions.

A limiter is a device that detects the level of the signal that it's receiving over a given interval or "time constant." When the input level crosses a certain threshold, for longer than a certain time period, the limiter introduces some degree of gain reduction. In turn, the gain reduction reduces the dynamic range of the program material that reaches the amplifier.

Limiters, and their close cousin Compressors, are used in music recording and sound reinforcement to create certain effects such as perpetual sustain of guitar and bass notes. They're also widely used to reduce or eliminate peak levels from vocalists, percussionists, and other dynamic sources, as well as often being employed to avoid overdriving amplifiers and speakers.

Limiters that are suitable for protecting loudspeaker systems are available as stand-alone products, as well as often being included as a function of many DSP based loudspeaker controllers or 'loudspeaker management systems.'

Limiters typically allow adjustment of some or all of the following parameters:

- Threshold
- Input Level
- Output Level (frequently called 'makeup gain')
- Attack Time
- Release Time
- Compression Ratio

Virtually all limiters allow the user to set the threshold, or level, at which point gain reduction will occur. Most models also permit the user to adjust the limit 'ratio.' Ratio refers to the magnitude of gain reduction. At a 2:1 ratio, every 2 dB increase in input level above the threshold will result in a 1 dB increase in output. At a 10:1 ratio, every 10 dB increase in level above the threshold will *also* result in a 1 dB increase in output. From these two examples, you can readily see how the Ratio control settings will affect the dynamic range.

Incidentally, the term 'limiting' generally refers to ratios of 10:1 or higher (some say 20:1), whereas 'compression' is the term used for lower ratios, such as 2:1 or 4:1. In fact, the only distinction between 'compression' and 'limiting' is the ratio of gain reduction.

Many limiters will allow the user to set the time constant that determine the length of the transients that are permitted to pass before the limiting function engages (this is called *Attack*), as well as the time span in which the limiter will 'recover,' or return to a state of non-limiting (called *Release*).

When used to protect a loudspeaker system, the limiter should be set so that gain reduction engages at some point before damage occurs to the drivers. If the threshold is set too low, the resultant sound quality will be 'squashed.' In other words, the dynamic range of the program material will be reduced to a degree that is audibly unpleasant. Conversely, if the threshold is set too high, the limiter will not engage early enough to protect the loudspeaker system from damage.

It is very difficult to suggest exact limiter settings, because the ideal setting for one system and one style of music may be undesirable for another system or another style of music. Coupled with this, the dynamic response characteristics of the amplifier(s) used in the system also play a large role in determining proper limiter adjustments. Amplifiers differ from one make and model to another in their dynamic headroom capability, sometimes greatly, and also in how they behave when they clip (see section on Amplifier Clipping on page 30 for more information on driver damage caused by clipping.) Because of this, we can offer only general guidelines on how to set up your system.

Following is a brief discussion on using limiters to protect loudspeaker systems:

- The limiter should be set so that it provides some measure of gain reduction before the amplifier(s) begin to clip. If the limiter is set so that it allows the amplifier(s) to go into hard clipping, it will do little to protect the drivers, except perhaps in the event of extended microphone feedback.
- If the system is large enough to handle the intended musical style in the size of room that it's designed to cover, i.e. if there are enough amplifiers and loudspeakers to provide the desired SPL (Sound Pressure Level) before the amplifiers reach clipping, then it will be possible to adjust the protective limiter so that the amplifiers never *can* go into clipping, even under abusive conditions. This will provide an excellent level of protection, without sacrificing headroom and sound quality.

Conversely, if the system is inadequately sized for the room, or just *barely* powerful enough, setting the limiter so that the amplifier(s) never goes into clipping is probably unrealistic. Such a setting will most likely result in less sound pressure level than desired, as well as a highly compressed sonic quality. In such case, you can either upgrade the sound system by adding loudspeakers and amplifiers, or you can make some intelligent compromises. By carefully adjusting the attack time, release time and threshold level, you can allow some of the peaks to get through to the amplifiers while still reducing the potential for damage from long-term abuse.

- A fast attack time (under 10 ms) will limit most of the peaks in normal program material. By lengthening the attack time, you can allow short transients to pass through (like a snare drum), while still reducing longer peaks like vocal and instrumental crescendos. This will improve the dynamic range, while still providing a measure of protection.
- Similarly, a long release time will tend to squash the program material, as well as introduce an audible ramp-up in level as the limiter slowly recovers. By shortening the release time, you can increase the short-term dynamic range. As long as the threshold is not set too high, the limiter can still aid in protecting the drivers from long-term overdrive, but not as thoroughly as it would in an adequately sized system.

Be cautious of very short attack and release times, as the detector circuits may start to track the individual cycles of a sustained low-frequency tone, creating a 'pumping' effect, almost like that of a tremolo circuit on a guitar amplifier.

It will take some experimentation to derive the best settings for each situation. Maximum power and voltage ratings are stated on the S-Series Specification Table on Page 9 in this manual; these may be used as an aid in calibrating limiter settings. Using a true RMS voltmeter, you can measure the output of your amplifier when driven by a sine wave generator, and adjust the limiter to prevent the amplifier's output voltage from exceeding the stated maximum. **Make sure to do this with the loudspeaker disconnected!**

Be aware, however, that static voltage settings made by taking measurements derived from exciting the system with a sine wave generator, or other constant voltage source, will represent only a part of the picture. The other part is the time constant. If the attack and decay times are too long, the limiter will not protect against short-term transients; in fact, it may never engage at all.

In summary, a protective limiter can go a long way towards preserving the lifespan of a loudspeaker system, but only if the system is sized properly to begin with and the limiter is carefully adjusted to properly complement the system. Obviously, it's safer to err on the conservative side, as the opposite approach may result in driver damage or complete system failure.

# CONNECTING THE AMPLIFIER TO THE LOUDSPEAKER

All S Series loudspeakers come with two methods of connecting the amplifier to the loudspeaker. One is a pair of industry standard NL4 type locking connectors, and the other is a pair of ¼" jacks. With the exception of the S-Series subwoofers, which feature a switchable High-Pass output, the four connectors are wired in parallel with each other on all full-range models.

When there's a choice, we recommend using the NL4 type connectors whenever possible. NL4 connectors have higher current handling capability than ¼" connectors. They're much easier to wire and far less prone to corrosion or mechanical degradation, which can result in an intermittent connection. Finally, they feature a positive locking mechanism when mated. If you've ever had a loudspeaker quit during a gig because someone tripped over the speaker cable, you'll appreciate the extra security of a locking speaker cable connector.



**IMPORTANT:** If you do elect to use ¼" loudspeaker cables, make sure to obtain high quality cables designed and built for loudspeakers. Never use signal cables made for guitars and keyboards, as they are not capable of handling the power. As such, they will degrade the sound quality and may even short out, or literally burn up under sustained usage.

***Figure 6: S-Series Full-Range Input Panel***

The following figure is an example of the input panel used on full-range S-Series loudspeakers.

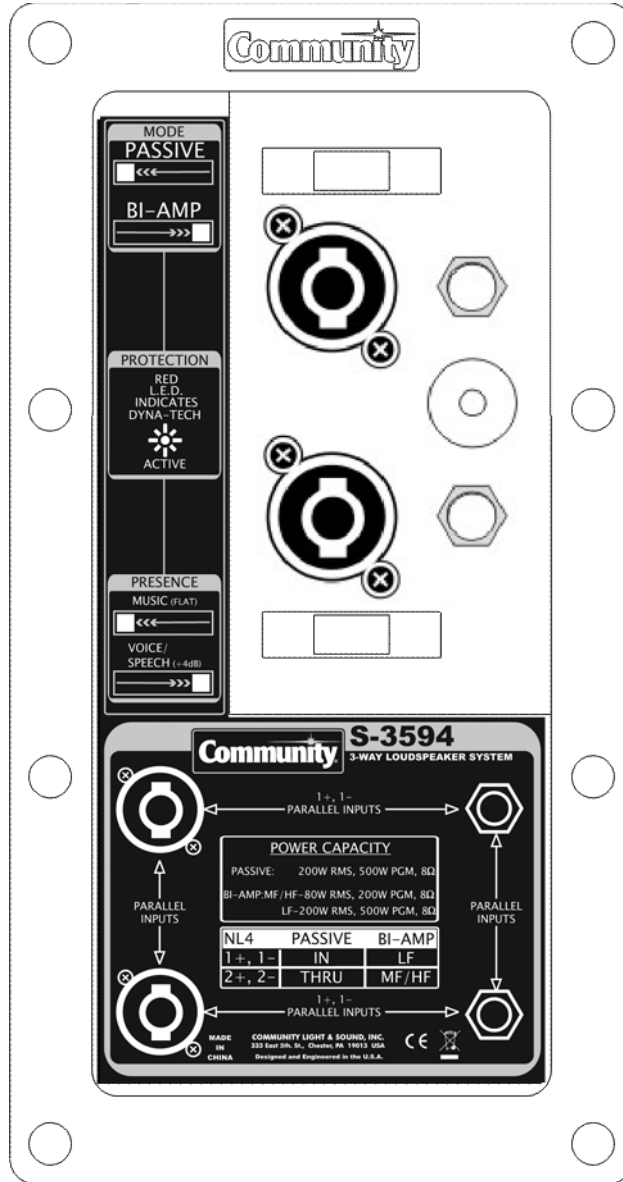

***Full-Range Input Panel (Typical)***

## PIN DESIGNATIONS

In **Passive Mode** the pin designation is as follows:

- **NL4 Pin 1+** and the *tip* of the ¼" **jack** connect to the positive (red) output of the amplifier.
- **NL4 Pin 1-** and the *sleeve* of the ¼" **jack** connect to the negative (black) output of the amplifier.

Internally, these pins are connected to the passive crossover in the loudspeaker.

Note: **Pin 1+ and 1-** and **Pin 2+ and 2-** are always connected in parallel to the second NL4 connector. However, only **Pin 1+ and 1-** are connected to the ¼" **jacks**, as they are two pole wiring devices. In the Passive Mode, **Pin 2+** and **Pin 2-** are not connected internally to any loudspeaker components.

In **Bi-amp Mode** the pin designation is as follows:

- **NL4 Pin 1+** connect to the positive (red) output of the amplifier powering the *low-frequency* driver.
- **NL4 Pin 1-** connect to the negative (black) output of the amplifier powering the *low-frequency* driver.
- **NL4 Pin 2+** connect to the positive (red) output of the amplifier powering the *high-frequency* driver.
- **NL4 Pin 2-** connect to the negative (black) output of the amplifier powering the *high-frequency* driver.

Internally these pins connect to their respective low-frequency and high-frequency drivers through the internal passive crossover circuits, thereby deriving an added degree of driver protection.



**IMPORTANT:** The ¼" jack is a two-pole wiring device and therefore cannot be used in the **Bi-amp Mode**. Bi-amping, by its nature, requires a four-pole connector.



**CAUTION:** Be sure to carefully observe polarity when wiring your loudspeaker(s). If one loudspeaker is wired with the opposite polarity from another loudspeaker, acoustic cancellation will occur. The result will be less total acoustic power output than if only one loudspeaker were used by itself.



### **Figure 7: S-Series Subwoofer Input Panel**

The following figure is an example of the input panel used on S-Series subwoofers.



***Subwoofer Input Panel (Typical)***

## **PIN DESIGNATIONS**

In the **Parallel Output Mode** the pin designation is as follows:

- **NL4 Pin 1+** and the **tip** of the **¼" jack** connect to the positive (red) output of the amplifier.
- **NL4 Pin 1-** and the **sleeve** of the **¼" jack** connect to the negative (black) output of the amplifier.

Internally, each of these pins are connected to the NL4 output connector, to the ¼" output jack, and to the drivers in the subwoofer.

In the **Hi-Pass Mode** the pin designation is as follows:

- **NL4 Pin 1+** and the **tip** of the **¼" jack** connect to the positive (red) output of the amplifier.
- **NL4 Pin 1-** and the **sleeve** of the **¼" jack** connect to the negative (black) output of the amplifier.
- Either the NL4 or the ¼" jack on the right side of the input panel may be used as hi-pass outputs to drive one or more full-range loudspeakers. These hi-pass outputs exhibit the response that is discussed in the section of this manual entitled "**SELECTABLE HIGH-PASS OUTPUTS ON SUBWOOFERS.**" This Section can be found on Page 16.

## WIRING NEUTRIK TYPE CONNECTORS

The diagrams below show how connections are made to a Neutrik Speakon™ style loudspeaker connector. Terminations may be soldered, or made by means of their built-in screw and pressure clamp. If using the pressure clamp, it's important to tighten it fully, then to wait about ten minutes (longer is better), then to tighten it again. This is because copper wire *flows* under pressure. After initially tightening the screw clamp, some minutes later the screw will no longer be as tight due to the effect of the compression on the copper. Typically, only one cycle of "tighten – wait – re-tighten" is required for a secure connection.

**Figure 8: Single Amp Connections**

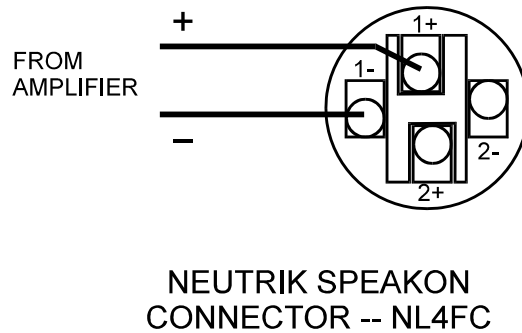

**Figure 9: Bi-amp Connections**

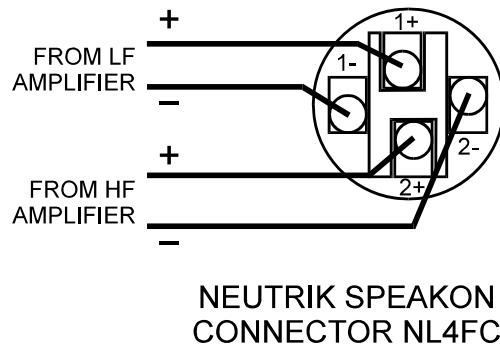

**DANGER:** When wiring the amplifier(s) to the loudspeaker(s), always power-down the amplifier(s) and disconnect their AC Mains plug(s). Many modern, high power amplifiers can deliver enough voltage and current to cause a harmful or lethal electric shock. Shocks from very low frequencies, such as kick drums, can cause the human heart to stop beating at relatively low power levels.



**WARNING:** After wiring the amplifier(s) to the loudspeaker(s), first power up all devices that are upstream of the amplifier, such as mixers, equalizers, compressor/limiters, etc., **before** powering-up the amplifier. This is to avoid passing any clicks or pops that may originate in the upstream devices to the loudspeakers. The amplifier should initially be powered-up with its gain controls turned all the way down. After making sure that a continuous signal is present, such as a CD playing, slowly raise the level of the gain controls to establish that the wiring has been installed correctly. Only then should the loudspeaker be operated at normal output levels.



**CAUTION WHEN BI-AMPING:** In the bi-amp mode, be particularly careful to insure that the connections to the low-frequency and high-frequency drivers have been wired correctly. If the amplifier channels are inadvertently swapped, the low-frequency content could cause damage to the high-frequency driver or your amplifier. At best, it will simply sound very bad.

## Impedance and Paralleling Loudspeakers

Loudspeakers of identical type may be connected together on the same amplifier. This forms a parallel circuit. When two loudspeakers are connected in parallel, the nominal impedance of the circuit will divide in half. For example, if two 8 ohm loudspeakers are wired in parallel, the result will be a 4 ohm load and the power from the amplifier (voltage x current) will be divided equally between both. If four 8 ohm (or two 4 ohm) loudspeakers are wired in parallel, the result will be a 2 ohm load. Again, the power will be divided equally among the loudspeakers.

If an uneven number of loudspeakers are to be connected in parallel, you can use the following formula to calculate the resultant impedance, where Z is the impedance in ohms:

$$(1/Z1) + (1/Z2) + (1/Z3) + \dots = (1/Zt) = Z.$$

In the above formula Z1 is the impedance of the first loudspeaker, Z2 is the impedance of the second loudspeaker, Z3 is the impedance of the third loudspeaker, etc., and Zt is the sum total of the loudspeaker impedances.

Here is an example using 3 loudspeakers, each with an 8 ohm impedance:

$$(1/8) + (1/8) + (1/8) = (1/0.375) = 2.6666 \text{ ohms.}$$

## Unequal Impedances

It's important to note that when wiring loudspeakers of unequal impedances in a parallel circuit, the power will **not** be divided equally among each loudspeaker. For example, if an 8 ohm and a 4 ohm loudspeaker are wired together in parallel, the resultant load will be 2.6 ohms. The 4 ohm loudspeaker will draw twice as much current from the amplifier as the 8 ohm loudspeaker. In this example, if the amplifier is capable of producing 1800 watts into the 2.6 ohm load of the combined loudspeakers, the 4 ohm loudspeaker will receive 1183 watts while the 8 ohm loudspeaker receives only 591 watts.

## Know Your Amplifier

Not all amplifiers can safely drive low-impedance loads, though usually 4 ohms and higher is not a problem. Very low impedance loads may cause the amplifier to clip prematurely, overheat, shutdown, or fail altogether due to internal device damage.

Even when an amplifier is quite stable driving a low impedance load, cable loss will be greater than with moderate impedance loads, damping factor will be reduced, and if the amplifier were to fail, a larger portion of the sound system is likely to be taken off-line due to the fact that a low impedance load implies a larger number of loudspeakers being powered from a common amplifier.



**C-TIP:** *Keeping the loads at 4 ohms or higher will lengthen the life of your amplifier(s) and improve the reliability and overall sound quality of the system.*

## Choosing Loudspeaker Wire

Wire and cable is used to transfer power between the amplifier and the loudspeaker. Wire and cable can be purchased with copper and aluminum conductors; for loudspeakers only copper conductors should be utilized.

The construction, conductor type, and insulation material of wire and cable vary widely. Wire can be purchased with solid core construction, stranded core construction, and densely stranded construction. Cables are typically available only as stranded or densely stranded.

Speakers may be driven through individual conductors bundled together and pulled through conduit, or through a cable made up of a number of conductors covered with an overall jacket, which then may or may not necessarily be installed in a conduit. Wire and cable manufacturers offer multi-conductor cables with 30 or more high current conductors

covered with a variety of jacket types. Jackets may be made of PVC, rubber, neoprene, and other materials, depending on the intended conditions of use.

Generally speaking, the wires and cables that power loudspeakers do not need to be twisted into pairs, though there is some benefit to doing so. A twisted pair of conductors has the effect of cancelling electro-magnetic radiation, thereby reducing mutual induction among circuits that share the same physical space (such as a cable tray or conduit), along with the crosstalk that might otherwise result.

Twisted pairs are commonly used for balanced line signal and microphone cables, in which the nominal voltages are very low and the input impedance of the load is typically quite high (>10K ohms). Under such conditions, the use of a twisted pair is essential to reduce crosstalk among adjacent cables. The twisting insures that the differential amplifier in a balanced line receiver will see identical phase and amplitude of any extraneous Electro Magnetic Interference (EMI) induced in the cable on both polarities, thereby allowing the EMI to be differentially cancelled.

In contrast, however, loudspeakers have input impedances that are quite low and operate on much higher voltages. The potential of inducing an audible signal from adjacent wiring is close to zero. The installer may, however, choose to use twisted pair loudspeaker cable for other reasons. Certain amplifiers may exhibit instability when driving long lengths of wire installed in conduit. A twisted pair will insure that the reactance of the loudspeaker cable is identical on both the plus and minus wires, thereby presenting a more stable load to the amplifier.

Note that when specifying multiple twisted pairs of speaker cables intended to share the same conduit, the conduit will need to be sized much larger than with loose or bundled conductors.

## Conductors and Insulation

Solid conductor wire is slightly less expensive than stranded wire, but much more difficult to pull through conduit. Also, it does not terminate to most speaker connectors as easily as stranded wire. Therefore, we recommend using stranded THHN type wire for installations that involve conduit.

Densely stranded cables, typically used for portable cordage, will coil up easily and lay flat on the stage, making them a good choice for applications requiring portability such as floor monitors. Typical examples are 14/2 and 14/4 SJO. Such cable is normally stocked in many hardware stores.

Wire and cable **insulation** is always rated for a working voltage and a maximum temperature. In power distribution systems, wire and cables can get very hot, making the temperature rating extremely important. When used with loudspeakers, the temperature of the wire or cable will hardly ever rise more than 10° C above ambient, and voltages will never exceed 300V (which is the *minimum* rating of most industrial wire and cable).

Special cables are manufactured for installation in air plenums, while others are made for direct burial. Use of such products can save a lot of time and expense compared to installing conduit. However, local, state, or federal building codes may require that loudspeaker cables be installed in conduit or in cable trays. It's a good idea to check applicable regulations carefully, before beginning the installation.

Conductors are sized according to a numbering system know as the American Wire Gauge, or AWG. Larger numbers, such as #22 or #24 indicate smaller diameter wire, while smaller numbers such as #10 and #12 indicate larger diameter wire.

The larger the diameter, the lower the resistance will be for a given conductor length. Resistance is normally stated *per foot*, or *per hundred feet* of wire. For example, #10 stranded copper THHN has a resistance of .204 ohms per hundred feet, though this can vary slightly among manufacturers.

The resistance of the wire, the impedance of the load, and the output voltage of the amplifier will determine how much loss occurs in the wire. These parameters also govern the damping factor of the amplifier/speaker combination (more on this later).

Below is a table that gives a quick look at the effect of wire size on line loss. These numbers assume that the amplifier is producing a constant 48 Volts at its output terminals, which is equivalent to 288 watts into 8Ω or 576 watts into 4Ω:

Size	Length	Load Z	Loss in dB
#10 AWG	100'	8Ω	-0.42 dB
#10 AWG	200'	8Ω	-0.83 dB
#10 AWG	100'	4Ω	-0.83 dB
#10 AWG	200'	4Ω	-1.58 dB
#12 AWG	100'	8Ω	-0.66 dB
#12 AWG	200'	8Ω	-1.28 dB
#12 AWG	100'	4Ω	-1.28 dB
#12 AWG	200'	4Ω	-2.39 dB
#14 AWG	100'	8Ω	-1.03 dB
#14 AWG	200'	8Ω	-1.95 dB
#14 AWG	100'	4Ω	-1.95 dB
#14 AWG	200'	4Ω	-3.55 dB

The worst-case scenario shown above is the 200' run of #14 AWG into a 4 ohm load. This will result in a staggering loss of -3.55 dB, or more than half of the amplifier's total power output. Use of wire that's one size smaller, #16 AWG, would cause a power loss of -5.11 dB. As you can readily see, it's very important to use the largest gauge wire that you possibly can, particularly when long lines are unavoidable. NL4-compatible connectors can easily accept #12 AWG.



**C-TIP:** *When choosing cable for a situation that requires only two conductors, consider using 14/4 (that is, #14 AWG with 4 conductors) and wiring each pair of conductors in parallel, at both ends of the cable. This will provide the equivalent conductance of #11 AWG, but in a cable that's more easily obtainable and smaller in diameter.*

## The Effect of Wire Gauge on Damping Factor

As significant as power loss can be, the effect of wire resistance on the damping factor of the loudspeaker/amplifier network is even greater for a given resistance value. (For a description of *Damping Factor*, see page 32)

Amplifier designers intend for the output impedance of their amplifiers to be as low as possible, in order to achieve a high damping factor. However, the laws of physics dictate that a very low output impedance will cause the resistance of the speaker cable to have a significant effect on the amplifier/speaker network. Unfortunately there's no way to get around it.

Example: With five feet of #10 AWG feeding a 4 ohm load, a given amplifier exhibits a respectable 100:1 damping factor. With fifty feet of #10 AWG feeding the same 4 ohm load, the damping factor decreases to 10:1, which is likely to be audible as a loss of 'punch' and tightness in the low frequencies.

Unless the power amplifiers are located directly alongside the loudspeakers (a good design technique to consider when possible), it will be difficult to maintain a high damping factor without using impractically large conductors. Therefore, keeping cable lengths as short as possible, is the most practical and cost-effective way to maintain a respectable damping factor without incurring undue difficulties.



**C-TIP:** Although it's beyond the scope of this manual to test and rate the many specialty loudspeaker cables sold in audio shops, studies conducted by skilled engineers have conclusively shown that the majority of such cables offer no real performance advantages (and in some cases, notable disadvantages) over that of good quality industrial grade wire.

## SELECTING AMPLIFIERS

Amplifiers are a vital part of any sound system's performance capability. As such, they should be carefully selected for appropriate power output, as well as for other attributes (more on this later). A table is provided below to help you size your amplifiers' power output capability to the various models in the S-Series.

Model	Recommended Power
S-1296 S-1596 S-3294 S-3594	Full-range (Passive Mode): 400 to 625 WRMS at 8Ω
S-1296 S-1596 S-3294 S-3594	Bi-amp Low-frequency: 400 to 625 WRMS at 8Ω Bi-amp High-frequency: 100 to 150 WRMS at 4Ω
S-215S Subwoofer	800 to 1250 WRMS at 4Ω
S-218S Subwoofer	1200 to 1875 WRMS at 4Ω

**Note:** "WRMS" = "Watts RMS" = "Watts Root Mean Squared"

## A WORD ABOUT CLIPPING

Clipping occurs when an amplifier is driven to the point where its *output* can no longer accurately reproduce the waveform presented at its *input*. When driven hard enough its output voltage can't swing any higher, so the resultant waveform is said to be clipped (see Figure 10 below).

**Figure 10: Effect of Clipping on a Sinewave**

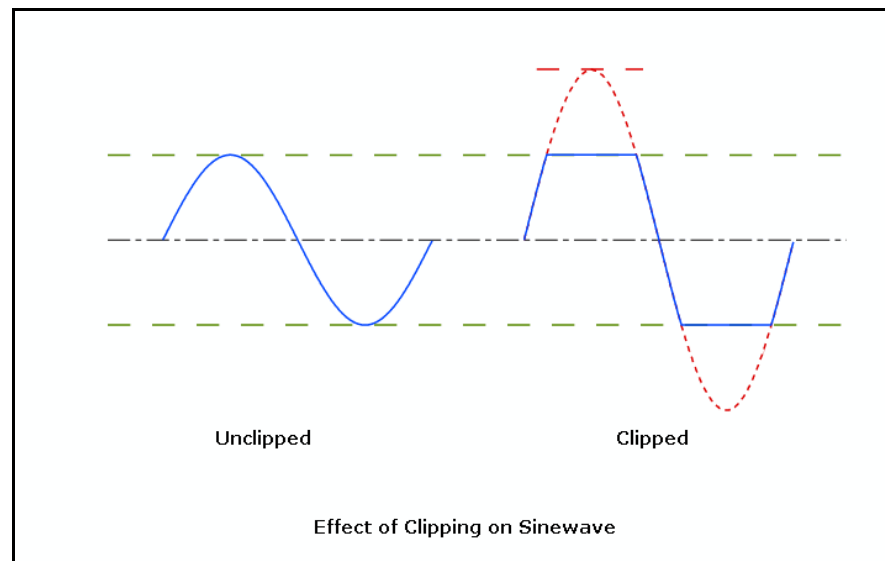

Most waveforms that occur in music and speech are the complex conjugate of sine and triangle waves. Such waveforms have a relative short *duty cycle*, cresting to maximum voltage for only a small part of each cyclic repetition. When an amplifier clips, it's because it's reached its maximum voltage potential, so it starts to square off the crest of the waveforms. This more or less turns the waveform into a square wave. Why is this bad? Because unlike a sine wave or a triangle wave, both of which crest for only a short duration, a square wave crests for a much longer duration. It can be described in technical terms as exhibiting a long *duty cycle*. In effect, a square wave is telling the loudspeaker to move forward in an infinitely short period of time – then to dwell there for a while – then to move backward in an infinitely short period of time – then to dwell there for a while – then to repeat the process. Whenever a loudspeaker has current running through its voice coil but is not actually moving, such as at the lengthy peaks of a square wave, all of the electrical energy is turned into heat instead of sound. Square waves will create rapid heating in even the most robust of drivers, leading to equally rapid driver failure. Therefore, it's better to choose an amplifier that's overly large for your loudspeaker but will remain out of clipping at high levels, than one that's too small and prone to clip.

Other attributes to consider in making a selection of amplifier type are:

- **Sound Quality**
- **Reliability**
- **Protection Circuitry**
- **Heat Dissipation Method**
- **Tolerance to Voltage Fluctuation**
- **Damping Factor**
- **Signal-to-Noise Ratio**
- **Controls and Features**

These items are briefly discussed below:

**Sound Quality:** Listen and compare! An amplifier that performs well in bi-amp mode with one manufacturer's loudspeaker may not perform as well when faced with the more complex load of a passive crossover in another manufacturer's loudspeaker. Make sure to listen!

**Construction Quality:** Usually, this is fairly evident by taking a good look at the product, but not always. Don't be fooled by excessively thick front panels that hide poorly built assemblies inside. Look inside if possible, **but first make sure that the amplifier is powered down and disconnected from the AC Mains before disassembling! An amplifier that's powered down and disconnected from the AC line can still cause a shock from the energy stored in its capacitors. Be cautious!** Things to note are an excessive number of internal connectors (hardwired terminations are typically more reliable); the quality of the pots, fans, and switches; the presence of wire jumpers and/or cut traces on PC boards (these indicate that the design wasn't ready for production); sheet metal screws versus machine screws (machine screws are stronger); and the method used to mount heavy components such as transformers and large capacitors (large bolts and steel brackets are typically better than small bolts and gobs of silicon).

**Protection Circuitry:** Most modern amplifiers can sustain a dead short to their output without damage. This is a good feature in the event that a driver shorts out, or wiring becomes faulty. Many designs have some protection scheme against DC on the output, which usually happens if an output transistor fails. This is another important feature as DC will almost instantly destroy LF and HF drivers. Many amplifiers offer some sort of 'soft' clipping protection, which again is usually a good feature if it's properly implemented. Review the specifications carefully.

**Heat Dissipation:** Does the amplifier use forced-air cooling (i.e. fans) or passive convection cooling? If forced air, can the fan filters be easily accessed and changed when they get blocked with dust? If convection, can the amplifier stand up to high ambient temperatures? Will there be a problem when multiple amplifiers are installed adjacent to each other in equipment racks? Some manufacturers recommend putting spaces between multiple amplifiers, especially passively cooled designs, which uses up a lot of valuable rack space. Investigate carefully.

**Tolerance to AC Mains Voltage Fluctuation:** Different designs of amplifiers exhibit widely differing behavior under fluctuating voltages. Those that are built with linear power supplies will typically exhibit a loss of power output capability when the AC mains voltage

falls below the amplifier's nominal rating (this is sometimes referred to as a brown-out), and they may shut down or be damaged if the AC voltage suddenly increases. Conversely, those that are built around switching-type power supplies may be tolerant of a drop in AC mains voltage with no loss of output capability. They may also be tolerant of an increase in AC voltage that's well above nominal. Many developing countries (and some parts of well-developed countries) routinely experience a wide range of voltage fluctuations, particularly during times of peak demand. Certain generators that are used to power outdoor systems may also exhibit wide voltage fluctuations. Before making a choice of amplifier type, it's a good idea to know as much as possible about the characteristics of the available power where the system is to be used.

**Damping Factor:** This specification refers to the amplifier's ability to dampen the motion of the driver during intervals when the amplifier is not producing output power. When a driver is energized, it continues to stay in motion for at least a few cycles after the power applied to it has been discontinued, from stored kinetic energy (momentum). During these intervals, such as in between kick drum beats, the driver is temporarily generating electric current that flows back into the amplifier (called back EMF). If the amplifier has a high damping factor, it will do a good job of electronically 'braking' or dampening the motion of the driver. This will result in an audibly tighter and punchier sound quality compared to an amplifier that has a poor damping factor. The effect of damping factor is especially pronounced when the amplifier is used with large, relatively heavy cone drivers, like those found in large-format subwoofers. This specification is typically expressed as a whole number or a ratio such as: >200 into 8 ohms or 200:1 into 8 ohms. A higher number is better.

**Signal-to-Noise Ratio:** Signal-to-noise ratio refers to how much hum and noise the amplifier produces. It is typically expressed as either a positive or negative number; e.g. >100 dB or -100 dB. A higher number, which indicates lower noise, is better.

**Slew Rate:** Slew rate refers to how rapidly the amplifier can produce output voltage when an input signal is applied. It is expressed as volts per microsecond (V/ $\mu$ s). Typical numbers range from 20V/ $\mu$ s to 40V/ $\mu$ s or higher. A high slew rate reflects an amplifier that can more accurately reproduce the dynamic content of the input signal. However, an amplifier with a lower slew rate may tend to sound bigger and warmer than one with a higher slew rate. Listen and compare (see **Sound Quality**).

**Controls and Features:** In addition to the standard gain controls and front panel lights, many of today's amplifiers offer such features as adjustable low pass filters, remote control of gain, remote monitoring of status, line voltage monitoring, and even full-blown DSP signal processing. Some installations may benefit greatly from such capabilities, while others may not need these features or cannot justify the extra cost. We recommend that you carefully align your budget with your actual needs. In most situations, you'll probably benefit more by installing an adequate number of loudspeakers and amplifiers, than by spending money on features that might not actually contribute to better performance.

## S-SERIES APPLICATIONS

The S-Series loudspeakers can fulfill numerous application requirements. Some of these are:

- Sound Reinforcement in Houses of Worship
- Theatrical Sound Reinforcement
- Coffee House Systems
- Music Reinforcement in Concert Halls & Performing Arts Centers
- Night Club and DJ Sound Systems
- Auditoria Sound Reproduction
- Presentations in Hotel Meeting Rooms and Ballrooms
- Health Club Exercise Music and Instruction
- Corporate Training Facilities
- Themed Entertainment Venues
- Retail Environments

S-Series loudspeakers are equally suited for use in system designs based on distributed speakers, exploded clusters, tight clusters, and arrays.



## General Application Guidelines

In choosing the right S-Series product for your application, the initial factors to consider are the size of the venue, the style of music and speech to be reproduced, and the location(s) of the loudspeaker(s).

In smaller venues with less demanding musical styles, one can usually achieve excellent results with either of the two smaller S-Series models. A good rule of thumb is to consider using a pair of the two-way S-1296 or S-1596 full-range models for venues that host up to approximately 200 persons.

By adding a second pair of either the S-1296 or S-1596 models, venues that host as many as 300 to 400 persons can be effectively covered. Each pair of enclosures may be configured side-by-side or one over another, to produce additional forward radiated power.

In rooms that are particularly wide but shallow in depth, a second pair may be required simply to obtain the necessary horizontal coverage, even if overall power is not an issue.

With its 15" cone driver, the S-1596 will provide additional low-frequency content than that of the S-1296 which has a 12" cone driver, resulting in a richer, fuller response. However, if either model is to be used with S-215S or S-218S subwoofers, the difference in the response between the 1296 and 1596 will be minimal.

S-3294 and S-3594 models are true three-way designs, employing horn loaded mid-range drivers in addition to their horn loaded high-frequency drivers. This design yields better directional control than a two-way system. The added directionality is an asset in reverberant rooms where it's important to keep the sound energy off of the walls, floor and ceiling, and/or when there's a need to cover long distances, either indoors or out.

The larger S-3594 with its 15" cone driver will provide deeper low-frequency response than that of the S-3294 which employs a 12" cone driver, but here again the difference in response will be minimal if either model is used with a S-Series subwoofer.

The S-Series includes two Subwoofers; the 215S employs dual 15" drivers, while the 218S features dual 18" drivers. Either model will add greatly increased power and extended low-frequency response to the S-Series full-range loudspeaker(s) that it's used with.

The smaller of the two, the 215S, is characterized by a tight, punchy sound, while the larger 218S adds deep, dramatic low end with a rapid transient response. When using multiple subwoofers, such as two or three on each side of the stage, it's best to keep the enclosures stacked or positioned tightly together for maximum mutual coupling.

If either the HIGH-PASS output on the subwoofer, or an external electronic crossover is employed, the use of a subwoofer will free up the low-frequency power demand on the full-range loudspeaker(s), thereby increasing output capability in the upper bass range. If an electronic crossover is used (highly recommended), *intermodulation distortion* in the amplifiers will also be reduced, resulting in maximum sonic performance.

***Note: The guidelines referred to above are "rules of thumb only." Performance will vary based on room acoustics, room geometry (particularly ceiling height), the location of the loudspeaker(s), the size and type of the amplifiers, and the stylistic demands of the music and speech that are to be reproduced.***

## POSITIONING SUBWOOFERS

Subwoofers are far less directional than the mid-range and high-frequency loudspeakers they are designed to augment. This is because low-frequency wavelengths are significantly longer than mid-range and high-frequency wavelengths. A 30 Hz wave is approximately 35 feet in length and a 100 Hz wave is approximately 11.3 feet in length. These extremely long wavelengths cause behavior that's quite different from their shorter mid and high-frequency counterparts.

First, long wavelengths do not 'see' small or moderate size obstructions as obstacles; they simply diffract around such barriers as if they're not there.

Second, the substantial length of low-frequency waves can make it difficult to distinguish their source direction. This is why a single subwoofer can often be used successfully to augment a stereo pair of mid-high loudspeakers, without unduly harming the stereo separation and image.

Third, low-frequency waves tend to add together quite graciously, even if their sources are separated by considerable distances, as long as they are in phase with each other. An example of this in operation is the typical *accentuation* or *build-up* of low-frequency content that is often experienced in the middle of theatres and concert halls, generated by subwoofers placed far apart on the opposite sides of the stage.

Overall, the characteristics mentioned above imply that the location of a subwoofer is not particularly critical, and to a certain extent that is true. However, there are several factors to consider before you finalize your intended location<sup>4</sup>. Some of these are:

- (1) A subwoofer will benefit greatly in terms of power output when it's placed adjacent to boundary surfaces. If located at the junction of three walls, such as on the floor or ceiling in a corner (called Eighth Space), a given subwoofer will produce a full 9dB more output than if that same subwoofer is located in Free Space (such as when suspended between the middle of a floor and ceiling). If located at the junction of two walls (Quarter Space), the subwoofer will produce 6dB more output than if suspended in Free Space. Located on a single wall, such as the floor or ceiling, the increase is 3dB. Free Power! What could be better? See Figure 11 for additional clarification:

**Figure 11: Effect of Boundary Surfaces on Power Output**

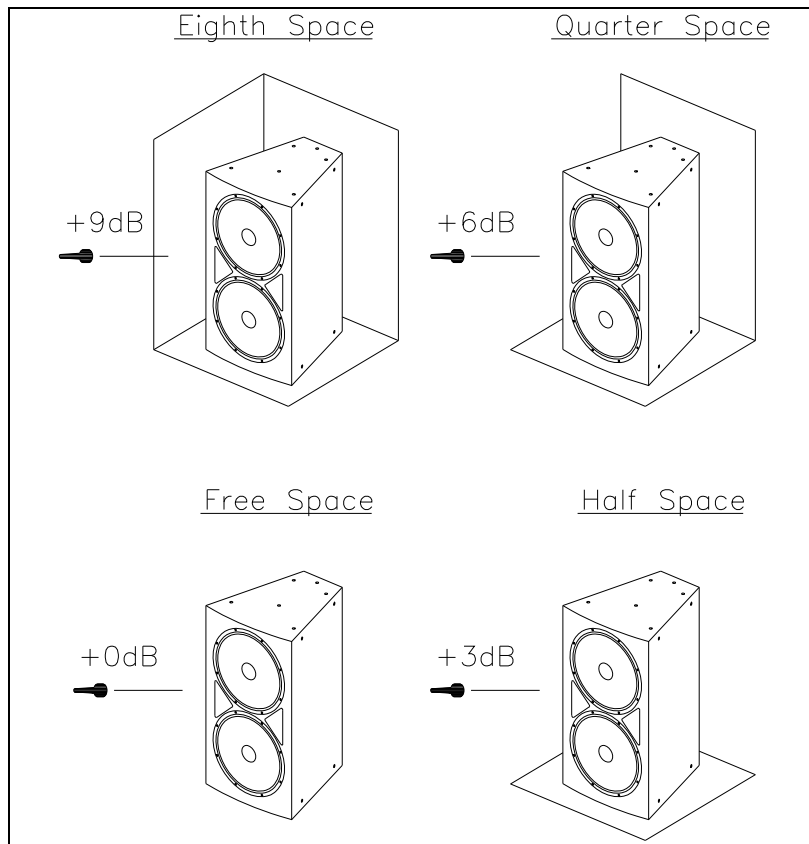

When choosing subwoofer location(s), be careful, however, not to sacrifice sonic quality for sheer power. If the available wall or corner location results in the subwoofer being located behind, or too close, to one or more open microphones, early feedback is likely to occur. If the wall or corner location is too far away from the full-range

<sup>4</sup> A thorough understanding of how low-frequency waves transmit in acoustical environments is very helpful when designing and installing optimum sound systems. We recommend reading, "Fundamentals of Sound" and "Psychoacoustics" by F. Alton Everest in the "Handbook for Sound Engineers" published by Howard Sams & Co.

loudspeaker(s), such location may result in the subwoofer being drastically out of time sync with one or more of the full-range speakers.

Sometimes the sound quality of a wall or corner placement is not desirable, simply due to the room's acoustical properties. Keep in mind that when wall and corner locations *are* appropriate for use they'll provide a tremendous increase in power output, but they may not always be the best choice.

- (2) Keeping the subwoofer(s) as close as possible to the mid and high loudspeaker(s) will decrease phase irregularities and *time smear*. If the subwoofer(s) is placed too far away from the mid/high loudspeaker(s), the listener will experience a disjointed character to the program material, causing the musicality of the system to suffer.
- (3) Although the subwoofer is not highly directional, still its acoustical output follows the inverse square law. That is, every time the distance from the subwoofer to the listener is doubled, the output level will decrease by 6dB. When covering a large space with multiple subwoofers, it may be of benefit to space them some distance apart from one another to even out the levels throughout the space. Typically, this would only be done if the mid/high loudspeakers are also spaced apart from one another, such as in a distributed system in a sports venue. Although this will help maintain an even level throughout the listening space, there may be some areas that lie between two or more subwoofers that experience a certain amount of power subtraction caused by *destructive interference*. Destructive interference occurs when waveforms meet and are partially or wholly out of phase with each other, due to unequal path lengths.

Conversely, if multiple subwoofers are located directly adjacent to one another, their power output will add together almost seamlessly. This is known as *constructive acoustic addition*. However, this may produce an undesirable hot-spot of low-frequency energy that may be too close to a seating area.

## ***Polarity***

Unless the full-range loudspeaker(s) is stacked directly on top of the subwoofer(s) with its cone drivers aligned with the subwoofer cone drivers, it's likely that the phase relationship of the two systems may not be optimal. This can be tested by reversing the polarity of one system relative to the other, as described below.

First, however, it's important to understand that the correct polarity of the full-range system relative to the subwoofer is a function of their physical placement in relation to one another. This is known as the Phase Relationship of the two systems, though Absolute Polarity plays a role as well, which will be discussed later.

Depending on the placement of the subwoofer in relation to the full-range loudspeaker(s), as well as the selected crossover point, the optimal response of the system might be obtained by reversing the polarity of the full-range loudspeaker(s). The easiest way to determine the proper polarity is to excite the system with a test signal (such as pink noise) and to view the resultant response on an audio spectrum analyzer. If such equipment is not available, it is also possible to determine the best polarity relationship by careful listening.

One orientation of polarity, either normal or reversed, should result in a discernable dip through the crossover region, due to acoustic cancellation. The opposite polarity should result in either a flat response or a peak through the crossover region, due to acoustic addition.

Note: When experimenting to determine the proper polarity, you can reverse the full-range loudspeaker(s) or the subwoofer, but never both at the same time (reversing both at the same time will not alter the phase relationship of the two systems). If there is one subwoofer and several full-range enclosures in the same system, it will, of course, be easier to reverse the subwoofer's polarity to test the response. Ultimately, as we'll see below, it's best to keep the subwoofer in a polarity-positive state.

If there is no discernable difference or only a very minimal difference in the measured or audible response when the polarity is reversed, it indicates one of two things:

- (1) The full-range system that the subwoofer is being used with does not reproduce enough low-frequency output to cause either cancellation or addition with the

subwoofer. This would be true if the full-range system is a very small loudspeaker, like those that are used for front-fill and underbalcony fill.

- (2) The placement of the subwoofer in relation to the full-range loudspeaker is not optimum. Little or no response variation will occur if the physical relationship results in an approximate  $\frac{1}{4}$  wavelength of offset at the center of the crossover frequency.

The solution to (1) is for both systems to remain in positive polarity. No harm will occur if the full-range system simply does not reproduce enough low-frequency energy to either add or cancel with the subwoofer's output.

The solution to (2) is to either change the physical relationship of the two systems, or to delay one of the two systems (whichever one is positioned closer to the listeners) with a digital delay. A high-quality, high resolution measurement system that can read and depict phase response or impulse response would be very useful in this situation. However, without such a system, you can determine an effective delay time by trial and error. Simply increment the delay time in small steps (1 ms), until the action of reversing the polarity produces maximum cancellation in one orientation and maximum addition in the opposite. By using a digital delay, you will have preserved the phase and impulse response of the system and you can now filter out any objectionable mid-bass overlap with an equalizer.

If a delay is not available, it is recommended that either the subwoofer or the full-range loudspeaker be relocated closer together, so that reversing the polarity of either the subwoofer or the full-range loudspeaker (but not both at once) will result in a distinct dip at crossover as discussed above.

If this cannot be done due to physical restrictions, the subwoofer and the full-range loudspeaker should be moved further apart, again until there is a distinct dip at the crossover frequency in one position of polarity. It may take some trial and error to determine the optimal physical relationships.



**C-TIP:** *It's a good idea to experiment with different loudspeaker locations by conducting listening tests before you finalize the locations (especially important in permanent installations). Make sure to use live microphones and live instruments (if applicable), as well as track playback. Choosing the physical location of the loudspeakers in the room is **always** the most important part of any successful system installation.*

Note that in some acoustical environments, the system may sound better when the phase relationship is non-optimum resulting in a dip at crossover, compared to optimum phase where the crossover region is *accentuated* by the overlap of the subwoofer and the full-range speaker(s). However, this is not the best way to achieve the sound that you're seeking. The proper course of action is to equalize (EQ) the peak at crossover with a parametric equalizer until the response is flat, or until you've achieved the tonal response you desire (we'll explain why below).

Alternatively, you might insert a high-pass filter in the full-range system (typically at 80 – 100 Hz with a 12dB/octave slope), so that the overlap with the subwoofer is reduced in magnitude.

A third technique is to increase the slope of the crossover to 24 dB per octave or 48 dB per octave, if the crossover has such capability, thereby reducing the bandwidth of the spectrum in which the two sources overlap.

There's an important reason for taking one or more of the measures discussed above. If that nice-sounding response dip at crossover is in fact due to phase cancellation, it means that the drivers and amplifiers will be working harder than they should to produce less sound pressure level than they are capable of, due to the acoustic cancellation taking place. All that cancelled energy uses power unnecessarily! Instead of putting the two systems out-of-phase to get the sound you want, if you attenuate the peak at crossover with any of the methods described above<sup>5</sup>, you are

---

<sup>5</sup> The three corrective methods referred to in the text, equalizing, high-passing, and increasing the slope of the crossover, are all various implementations of equalization.

*reducing* the power that's required to obtain a given sound pressure level. This will result in more available power, more headroom and less demand on the drivers, all of which lowers the potential for distortion and damage under high power conditions.

Now that you've chosen the final physical locations for your full-range loudspeakers and subwoofers, established their optimum phase relationship, and brilliantly EQ'd any crossover peaks, you're almost ready to permanently wire the system. But first read the section below on "Absolute Polarity."

## ***Absolute Polarity***

Quite a bit has been written about ***absolute polarity***, particularly in regard to studio recording and hi-fi sound reproduction. The subject is, however, often ignored in the field of sound reinforcement. Essentially, positive ***absolute polarity*** refers to configuring the system so that upon the first cycle of excitation by the source material, the driver(s) moves forward *toward* the listener, thereby producing a positive wavefront. For example, at the instant of impact when the head of the kick drum moves outward towards the microphone, the speaker cones will also move outward.

Obviously, the polarity integrity of the entire signal processing chain must be maintained for this to occur. Is absolute polarity audible? Should you be concerned? Yes, it is audible and though subtle, it makes a big enough difference to warrant taking the time needed to insure that the signal chain is polarity-positive throughout. You'll hear an improvement in sonic impact, especially in the lower frequencies.

We recommend that absolute polarity be kept positive in all low-frequency devices whenever possible. This can be checked with a small handheld style polarity response test unit, available from numerous manufacturers.

Although it's easy to simply reverse the polarity of the subwoofer to determine its best polarity relationship to the full-range loudspeaker system, if the best position turns out to be reversed we recommend that you instead reverse the full-range system(s) so that the subwoofer(s) can remain in a state of positive absolute polarity.

## **SYSTEM EQUALIZATION**

There are numerous schools of thought on proper equalization techniques. Some believe that using anything more than a touch of equalization is wrong, often attributing their concerns to 'phase shift' from the equalizer. Others believe the opposite. Some say equalization can't be performed correctly without advanced instrumentation, while others say it must be done by listening; after all, the end product isn't a graphic display, it's an audible event.

One engineer would never equalize a sound system with a parametric equalizer, while another would not use a graphic equalizer. A well known sound designer once stated that when the equalizer is switched in and out, if he couldn't hear the difference, he considered the system to be properly tuned. As these examples illustrate, there are widely varying beliefs on the subject of equalization.

Instead of touting a particular philosophy, let's approach the practice of equalization by looking at the transfer function of the loudspeaker and room together. We can do this with a two-port FFT analyzer.

For the sake of this short discussion, let's assume that the loudspeaker we're using exhibits a perfectly flat frequency and phase response in a free field environment. We're going to assume this because it will help to illustrate the point of the discussion. The fact that few, if any, loudspeakers are perfectly flat in a free field environment is not of paramount importance, nor is the fact that many high quality loudspeakers can actually *be* equalized to be almost perfectly flat, if one wants to go through the exercise of doing so. The point here is to illustrate the principal of precisely correcting for room resonance.

So here we have a loudspeaker installed in a room. We already know that this loudspeaker exhibits a flat response in a free field environment, such as outdoors or in an anechoic chamber. But what happens when it's installed in a room?

Logic dictates that whatever changes occur to the response of the loudspeaker in the room, are dependant *entirely* on the effect of the room (unless, of course we wired the loudspeaker wrong, or broke it in transit...which we didn't).

Now as we listen to our loudspeaker, we hear things we didn't hear in the free field environment. It sounds bass heavy. It sounds like there's a buildup of energy somewhere; say around 300 Hz. We also hear something happening at about 600 Hz. What do we do?

Let's measure it. Let's assume we have a narrow band, a high resolution FFT-based<sup>6</sup> measurement instrument and a perfectly flat microphone (these do actually exist). Should we measure it nearfield, say about 1 meter away? Why not? Somewhere we heard that's a good thing to do.

We place the microphone about 1 meter from the loudspeaker and we look at the response. It's quite flat. Not like it looked when we measured it outdoors, but not all that different. Overall, the lower frequencies exhibit a gradual rise in amplitude as they drop in frequency, but there's also some 'rolling hills' up to about 800 Hz.

We grab our graphic equalizer and try to smooth out these rolling hills and the rise in the bass response. A cut at 63 Hz merely puts a hole in the response at 63 Hz; it doesn't fix the rolling hills. But the loudspeaker does sound less bass heavy when we run the music track. More cuts at 125 and 250 again help it to sound less bass heavy, but we can clearly see we're 'chopping up' the response curve. Maybe these minimalist guys are right...too much EQ really chops things up! Too bad there's not a filter on this thing that produces the inverse of the whole response shape.

Let's try moving the mic to the mix position. That's seems to be a good idea. Put the mic where the sound operator is.

Wow. Now there's a whole new picture. The holes from the graphic can barely be seen anymore. Instead, there's a big bump at 362 Hz and again at 725 Hz, and the whole low end is even more accentuated.

We try using the graphic to flatten the response. We try for a long time, but no combination of filters will flatten the low end. Pulling down 315 takes part of the 362 Hz bump out, but not all of it. Pulling down 400 just puts a hole above the bump at 362 and makes the bump look even bigger than before. Same problem at 725 Hz. "This isn't working! It must be true... you can't really EQ a room."<sup>7</sup>

Someone says, "Let's try this parametric equalizer instead." You're ready to do anything. After setting it up, you've found it has a shelving filter with an adjustable turnover frequency. You try cutting it 8 dB and the whole low end quickly flattens, except for the 362 Hz bump. But the slope's not quite right. There's still a quick rise around 900. You move the turnover frequency up to 900. Like magic, the whole low end is now flat except for the bumps at 362 and 725. Engaging a bandpass filter, you dial up a peak of 4 dB making the bandwidth quite narrow. In a few seconds, you've easily centered the peak squarely on the bump at 362 Hz. Now you cut it and fiddle with the Q. In a few more seconds, the bump is gone. No trace.

You repeat the process at 725. Again it's gone without a trace. But this has to play havoc with the phase, doesn't it? Something *has* to be wrong. It's too easy.

The guy who owns the FFT tells you that because you're looking at the transfer function of the loudspeaker in the room, you can also see the phase response if you want to. He pushes a few buttons and there on the screen is a phase response trace, along with the frequency response trace. It looks remarkably flat from about 200 Hz up to 1 kHz or so. You bypass the equalizer and the bumps are back, along with the big rise in low end. Remarkably, the phase trace now shows two wiggles, dead centered on the 362 and 725

---

<sup>6</sup> FFT is an acronym standing for Fast Fourier Transform and is based on the Discrete Fourier Transform, a mathematical algorithm defined by French mathematician Jean Fourier. FFT measurement instruments are vitally important to the study of sound and vibration.

<sup>7</sup> No matter what technique you use you can't, of course, EQ a room; you can only EQ the sound system in the room. But much of the world refers to the process of equalizing a system as 'room-tuning.'

bumps, and an overall drop that looks like the inverse of the low-frequency rise. You feel a little like Alice in Wonderland. When the equalizer was switched in, the filters actually *improved* the phase response! You've got to get your hands on one of these FFT things, and soon.

# # #

OK. Let's put this event into more scientific terminology. Here's what's happening: The loudspeaker is transferring its acoustic energy into the room. This energy presents itself in the form of pressure waves, causing cyclical pressure and rarefaction in the room's atmosphere. Under excitation, the volume of air in the room begins to resonate, as confined volumes of air tend to do. This is not a particularly large room, so its primary resonant frequency is quite high at 362 Hz<sup>8</sup>. The second harmonic of that frequency is also present at 725 Hz. Going back and looking more carefully, one would probably see additional third order harmonic resonant modes, and possibly a sub fundamental mode as well.

Other parts of the room, particularly if it's a complex architectural design, might exhibit their own resonant modes at different frequencies, such as in the underbalcony area.

But why was the phase response improved merely by applying frequency equalization? The answer is simple. The peaks in amplitude at 362 and 725 Hz that were removed by the equalizer were caused by systemic resonance (the 'system' being the sum of the loudspeaker and the room). Because it takes time to complete a period of resonance, this time period alters the systemic phase response as well as the frequency response. If one could precisely cancel out the variation in phase response with an FIR filter, the result would be the inverse, or a perfectly flat frequency response curve. It's a wholly organic process in which phase response and frequency response are intrinsically linked.

The ideas and techniques described above can be extended to arrays, clusters, delay systems and distributed systems. Managing the various zones of a large-scale sound system is, of course, much more complicated, but the basic techniques remain the same.

Properly applied, equalization can be a powerful tool with benefits extending even into the time domain, as we've illustrated above. The potential for radical improvement in both the phase and frequency response, through the use of precision equalization, can even make a large, reverberant room sound significantly 'smaller.' This is because the reverberant field in a room is typically longer and higher in amplitude at frequencies where it exhibits excessive resonance, than throughout the remainder of the audible spectrum. By reducing the energy from the sound system at those resonant frequencies, the room may no longer sound particularly reverberant at all.

When using precise measurement equipment, additional useful processes can be brought to bear. For example, instead of flattening the ancillary underbalcony and over balcony systems, first look at the spectral content of the energy that's arriving in those areas solely from the main array(s) located far forward in the room. Typically you'll see that there's already too much low-frequency content. You might also see a local zone resonance that wasn't noticeable in the forward section of the room. And there might be an excess of energy at some particular mid-spectrum frequency.

By shaping the delay system to add only the portion of the spectrum that's lacking from the main house array(s), and precisely delaying it to within a millisecond of the true propagation time, these ancillary systems can wonderfully improve the listener's experience in what are often called the 'cheap seats.' Additionally, when an ancillary delay system is *additively aligned* as described above, its overall energy contribution is lower and therefore it's far less prone to reflecting energy back into the room, which could quite possibly corrupt the sound in the forward seating areas.

This 'additive' technique can be applied to front fill loudspeakers, down fill loudspeakers, and any other area where multiple systems overlap in a shared acoustic space.

### ***Precedence (The Haas Effect)***

The Haas Effect, or precedence effect, is named after Helmut Haas who first described it in his doctoral dissertation. It states, in part, that one sound source may be as much as 10

---

<sup>8</sup> In a real life situation the primary room resonant frequency would tend to be much lower, but it's easier to illustrate the principal in a range where the graphic equalizer has more available bands.

dB greater in intensity than another, but will not be identified as the location that the sound is coming from, if it arrives later than the lower intensity source.

This effect can be used to make underbalcony, overbalcony, and other delayed loudspeakers acoustically 'disappear,' drawing the listener's attention to the stage rather than to the ancillary delay speaker. The idea is to first find the correct delay time that will align the output of the ancillary loudspeaker with the output of the primary source, then to increase the delay time of the ancillary loudspeaker to take advantage of the effect.

If the correct delay time is accurately identified within a range of one to two milliseconds, the additional delay required to take advantage of the Haas Effect can be as little as two to three milliseconds. The exact value should take into account the overall distance between the two sources. Greater distances require slightly longer additional delay times in order to compensate for variances in the velocity of sound as the temperature in the environment changes.

### **Why not equalize by listening? After all, the end product is sound!**

That's true, but you're probably not going to listen to swept sine waves, you're more likely to be listening to music. Even if you've trained your hearing to a very fine degree and you possess perfect pitch, you can easily miss room resonant modes if the music you're listening to is in one musical key, and the room resonance happens to lie outside of that key.

While some rooms exhibit broad resonant peaks that are readily detectable by listening, others have quite narrow ones that can be easily missed. Typically, the bandwidth of room resonance is often close to one-third octave, hence the development of the third-octave equalizer. Unfortunately, most rooms aren't cooperative enough to exhibit resonance that falls precisely on ISO frequency centers, which makes the third-octave equalizer an imprecise correction tool.

Even if a room resonant mode *does* fall on an ISO frequency center, its resonant frequency will shift upwards when the room fills with patrons and the volume of air is reduced by the displacement of solid bodies. An FFT type analyzer will let you see this effect, and a parametric equalizer will allow you to adjust for it. With an FFT you can even use music as your 'test tone' to continually measure the changes in the room response during a performance, because a two-port FFT set to take continual measurements in the transfer function mode doesn't care what the signal is; it's just as happy resolving music as it is resolving pink noise, swept sine waves, or other sources. Noise just happens to provide much faster results, because of its broadband nature.

## **RIGGING AND MOUNTING S-SERIES ENCLOSURES**

One of the most important tasks the installer faces is the rigging and mounting of the loudspeaker system. S-Series loudspeakers have been designed with rigging and mounting in mind; thus, there are numerous ways to safely and easily install S-Series loudspeakers in optimal locations in the venue.

### **SAFETY FIRST!**

There is no way to overemphasize the importance of safety. But we'll try. The kinetic energy of an 80 lb. loudspeaker enclosure dropping from 30 feet and contacting a concrete floor is enormous. The loudspeaker will be traveling at a speed of about 35 miles per hour at the time of impact. Imagine if you were seated under it. You might have a better chance of surviving a dynamite blast.

If you do not have knowledge of safe rigging practices and experience in applying them, contact a qualified rigging contractor to design and carry out the installation! Rigging that is improperly installed is like a time bomb; sooner or later it will fail, with the potential to cause serious injury, paralysis, dismemberment, or loss of life. Even if no one is directly in the line-of-fall of a failed suspension system, the panic that might ensue could in itself cause multiple deaths. Do not take chances!



## RIGGING GUIDELINES

The following guidelines on rigging are *not* intended as a comprehensive rigging manual, nor are they meant to replace the knowledge of safe rigging practices that might be obtained from receiving professional training on the subject. These guidelines are intended *only* to provide basic safety information, and to call your attention to some commonly made mistakes. Books, seminars, and hands-on courses are available that teach safe rigging techniques; we highly recommend that you seek them out if you do not already possess the requisite knowledge and experience to perform rigging work safely.

**DISCLAIMER:** Community warrants that its loudspeaker systems and its optional mounting and rigging hardware have been carefully designed and tested. Community loudspeakers may be safely mounted and rigged when each loudspeaker model is installed with Community-manufactured optional mounting and rigging brackets specifically designed for use with that particular model of loudspeaker. This warranty applies only for use under normal environmental conditions,<sup>9</sup> and when all loudspeakers, component parts, brackets and hardware are assembled and installed in strict accordance with Community's installation guidelines contained herein. Beyond this, Community assumes no further or extended responsibility or liability, in any way or by any means whatsoever. It is the responsibility of the installer to insure that safe installation practices are followed, and that such practices are in accordance with any and all local, state, federal, or other, codes, conditions, and regulations that may apply to, or govern the practice of, rigging, mounting, and construction work in the relevant geographic territory. Any modifications made to any parts or materials manufactured or supplied by Community shall immediately void all pledges of warranty or surety, related in any way to the safe use of those parts and materials.

### 1. Load Rated Components

All components of the rigging system such as wire rope, shackles, chains, eyebolts, etc., must be load rated. This means that they are marked or rated with a **Safe Working Load (SWL)** or **Working Load Limit (WLL)**. All such items should be designed and manufactured by reputable companies that regularly supply the theatrical and industrial rigging industries, such as The Crosby Group, or equivalent. It is strongly recommended that you source your rigging items from an industrial supplier or specialty rigging house, never from a hardware store. Items found in local hardware stores are often poor copies of the original designs and may not be safe, as well as typically being more costly than items purchased from an industrial supplier. By planning ahead, you will not be in the uncomfortable position of having to delay the work if you can't locate a shackle or eyebolt at the last minute.

### 2. Safety Factor

No component in a rigging system should be stressed to its maximum load rating. A suitable **Safety Factor** or **Design Factor** must be determined and applied, so that every component in the rigging system has reserve load capacity. The manufacturer's stated SWL (Safe Working Load) or WLL (Working Load Limit) is the quotient of the component's ultimate strength, or breaking point, divided by the manufacturer's stated safety factor. If the safety factor is not stated on the component or in the manufacturer's technical specification sheet, the component should not be used, as its ultimate strength is unknown.

In addition to the manufacturer's rated Safety Factor, the prudent installer will determine and apply an additional Safety Factor to insure that the suspension system is installed in a manner that cannot fail under the prevailing conditions.

Safety factors may be regulated by local, state, federal or international agencies and therefore may vary based on your geographic location. Safety factors typically assume normal environmental conditions; additional consideration must be given when unusual conditions are encountered, such as in corrosive marine environments (e.g. loudspeakers

---

<sup>9</sup> Normal Environmental Conditions are defined as the following: -15 to 55° C, no excessive or unusual air-borne contaminants or pollutants present, no chemicals or contaminants coming in direct contact with the product, no excessive vibration or wind loads.

mounted on a cruise ship or in a venue located near sea water), or in conditions involving high-vibration, high wind-loads, or other unusual conditions. A common safety factor is a 6:1 ratio; however many theatrical rigging companies voluntarily work at a 7:1 ratio or higher. A 10:1 ratio is required in most countries that are members of the European Union. At a 10:1 ratio, this means that a component rated at 10,000 lbs of ultimate strength should never be subjected to a load greater than 1,000 lbs. The de-rated value of 1,000 lbs should take into account the additional force of dynamic loading, such as when a motorized hoist starts and stops. Such dynamic loading can easily exceed 200% of the static load and is dependent on the hoist design, how close to capacity it is loaded, the length of the cable or chain, and the elasticity of the supporting structure.

### **Seismic Considerations**

Seismic events (earthquakes) can cause great dynamic loading of a rigging system. In the case of strong quakes, which occur regularly in some regions, a rigged system may merely sway back and forth with no damage, or it may be subjected to many times its static load rating, particularly in the case of unequal loading of a multi-part suspension system due to uneven roof or beam movement. It's also possible that one loudspeaker rig may contact another rig or a lighting truss, during the quake. The results cannot be predicted because seismic events occur with differing forms of wave motion at varying axes to the suspended system. An earthquake might produce long, rolling waves in one axis then later, an aftershock on the same day could produce short, violent waves in another axis.

### **Aging of Components**

Over time, hardware components used for rigging will degrade, causing them to lose some, or even much, of their load capacity. Factors include strain, oxidation, exposure to corrosive or acidic atmospheric conditions, exposure to water and chemicals, exposure to UV light, and metal fatigue. In consideration of long-term durability, a high safety factor should always be chosen, particularly when future conditions cannot be clearly foreseen (which is almost always the case).

## **3. Safety Cable**

All loudspeakers, lighting instruments and any other object that is rigged or suspended in any way (this includes the use of wall brackets) must be fitted with one or more safety cables. Safety cables are a backup method of suspension intended to keep the rigged object in the air, in the event that the primary suspension system fails.

Safety cables must be sized appropriately for the loads they will carry, and should be attached to a different point or points on the wall, ceiling, truss, frame, bumper, or other support device, than that of the primary suspension system. They should also be attached to a different point or points on the objects that are being suspended.

### **Shock Loading of Safety Cables**

A safety cable must have as little slack in it as possible so that if the primary suspension system fails, causing the load to switch from the primary suspension to the backup safety cable, the shock will be minimized. An object that falls and is caught up short places enormous strain on its safety cable. A 100 lb loudspeaker falling just several inches, can create a shock load as great as 500 lbs. It's difficult to precisely calculate the strain of a shock load unless you know the elasticity of the safety cable as well as all other components in the suspension system. Suffice it to say that this is rarely known with accuracy. Therefore, in order to insure safety, the total potential stress subjected to the safety cable and any components that are used with it, should always be a small fraction of the ultimate breaking strength of the weakest component.

#### 4. Load Angles

This is an area that is often misunderstood, so let's clear it up. Whenever an object is suspended from one point, it has no choice but to hang directly below that point of suspension; in other words at a zero degree angle to the suspension point. When an object is suspended from more than one point, the points may or may not be at zero degrees to the object, they form a *bridle*. As the angle of the bridle increases, the force through each leg of the bridle also increases (see Figure 12 below). A high angle bridle can produce forces in the suspension legs that are many times the weight of the suspended object. This is counterintuitive, as most people's understanding of physics would suggest that the object cannot produce a greater load than that of its own weight. Not true. For example, a 100 lb. object can produce 300 lbs. of force at a bridle angle that may not appear dangerous to the untrained observer. At very steep angles, the load can far exceed the rating of even the most robust rigging components, in addition to placing an enormous compression or expansion force on the object itself (depending on the direction of the bridle). Therefore, steep bridle angles are to be avoided under all circumstances.

**Figure 12: Load Angles**

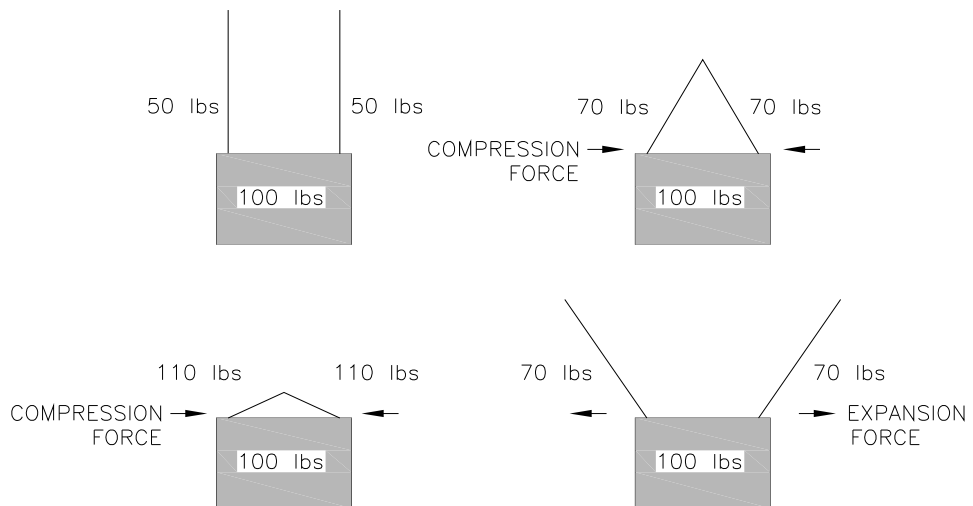

Even more dangerous, is the practice of reeving a suspension cable or sling through two shackles or eyebolts, forming a type of basket hitch (see Figure 13). This again increases the force through each leg, as well as significantly increasing the loading on the shackles. It also allows the load to easily tip or shift its weight in the hitch. It should always be avoided.

**Figure 13: Never Reeve Cables!**

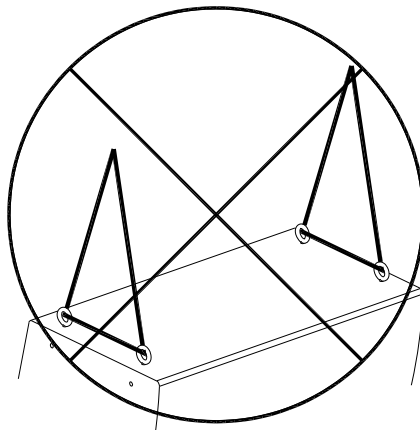

## 5. Wire Rope Clips

Wire rope clips, sometimes called "Crosbys" after one manufacturer, should always be of the drop-forged type, never of malleable steel. They must always be installed in accordance with the manufacturer's instructions and specifications. Although specific instructions will vary depending on the design of the clips and the diameter of the wire rope, they will always include the number of clips, the length of the turn back, the spacing of the clips, torque of the nuts, and the orientation of the U-bolt. Using too few clips, too little turn back, spacing the clips improperly, over-tightening or under-tightening the nuts, and improperly orienting the U-bolts can all cause catastrophic failure. Overlooking the importance of re-tightening the nuts after load is applied can also lead to failure. The prudent installer will be prepared in advance, carrying a calibrated torque wrench in the toolbox.

As a general rule there should never be *less* than three wire rope clips on wire rope of 1/8" to 1/4" in diameter, and more on larger diameters. Clips should be evenly spaced and the U-bolts should always be oriented so that they are on the dead end of the wire rope, as they can cause damage to the live end. Wire rope that's properly terminated with high-grade rope clips will result in approximately 80% of the strength of the wire rope itself. Example: If a specific wire rope has a rated Working Load Limit of 1000 lbs., that rating will be reduced to 800 lbs. when the wire rope is terminated with wire rope clips. Conversely, Nicopress fittings (see below) are capable of providing terminations that are equal to the strength of the wire rope itself.

## 6. Nicopress® Fittings

Like wire rope clips, Nicopress fittings are used to terminate wire rope ends. They consist of an oval sleeve of malleable metal (typically copper, aluminum or stainless steel) that's pressed onto the wire rope with significant force using a specially designed tool. Nicopress is the proprietary brand name of one manufacturer, but has become nearly a generic name among riggers. As with wire rope clips, fittings of similar design to Nicopress are available from multiple manufacturers of varying quality. If high grade fittings are properly installed with the correct tool (this is a big "if"), they will form a termination that is equal in strength to the wire rope itself. As with all rigging components, it is highly recommended that you purchase such fittings and tools from professional supply houses, not from local hardware stores. Genuine Nicopress tools come equipped with a calibration gauge to insure that the tool is performing properly on every fitting over time.

## 7. Shackles

Only industrial grade load-rated shackles should be used to attach wire rope or fabric slings to hang points. The use of rapid links, Quicklinks, clip locks and other non-rated hardware items should absolutely be avoided. Shackles and other high-strength forged components must never be dropped onto hard surfaces, such as concrete. If a shackle is dropped more than a foot onto concrete, discard it. The impact of the fall could cause the metal to crystallize, leading to early failure.

## 8. Eyebolts

Eyebolts are often used to suspend single loudspeakers, arrays, and clusters of loudspeakers. Some of Community's S-Series rigging accessories are designed to utilize eyebolts. Eyebolts are available in several styles and materials. Some of the most common are:

- Formed steel plain eyebolts;
- Forged steel plain eyebolts;
- Forged steel shoulder eyebolts (sometimes called "machine eyebolts").

For loudspeaker rigging, only rated forged steel shoulder eyebolts purchased from a reputable manufacturer, should be utilized. Community offers this style of eyebolt at a reasonable cost.

The SWL or WLL rating of any eyebolt is based on a straight line pull. If the load angle varies from that of a straight line, the load rating rapidly decreases. At 45° the eyebolt has

only 30% of its rated strength. At 90° it is de-rated to only 25%. Use at angles steeper than 45° is strongly discouraged. Such use would be permissible for breasting back a loudspeaker to alter its downward angle, where the breast line is *not* part of the suspension system nor is it considered to be the safety cable. Vertically rigging a loudspeaker from eyebolts placed into its side surfaces (90°) must always be avoided. When eyebolts must be angularly loaded, it's vitally important to design any multi-point suspension installation with a low bridle angle (see **Load Angles**), and to de-rate the eyebolt accordingly.

### Proper Tightening of Eyebolts

If the shoulder eyebolt is not properly tightened, its angular load bearing ability will significantly decrease, leading to rapid failure. Make sure to follow the eyebolt manufacturer's instructions for proper tightening. The prudent installer will be prepared in advance, carrying a calibrated torque-wrench in the toolbox and a way of coupling it to the eyebolt. We recommend cutting a groove into the sides of a large socket, as a means of using the torque-wrench to tighten the eyebolt.

### Eyebolt Orientation

A shoulder eyebolt should only be angularly loaded in the long axis of the loop of the eye; it should never be laterally loaded. Loading against the axis of the eye can cause breakage at even very low force. After tightening the eyebolt, if the eye is not aligned axially to the line-of-force, a shim or washer should be installed to re-position the eye. The eyebolt should never be loosened or over-tightened as a way of aligning its axial orientation. If you're equipped in advance with a variety of washers and shim material, you'll be able to safely install eyebolts quickly and painlessly.

Lastly, ***never*** reeve slings in a basket-type hitch through eyebolts (see Figure 14 below). Doing so will radically increase the strain on the eyebolts and on the slings from vector loading, as well as permitting the load to tip or shift.

**Figure 14: Never Reeve Cables!**

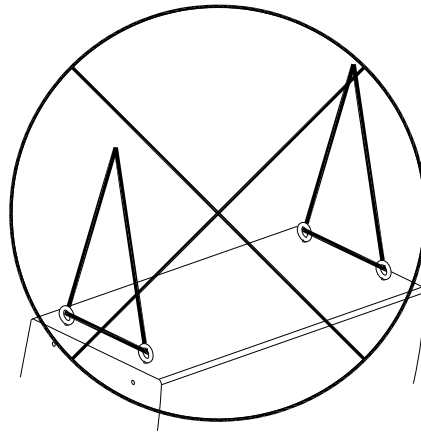

## 9. Threaded Fasteners

Threaded fasteners are often used in rigging and mounting systems. As with eyebolts, many of Community's optional mounting brackets, yokes, and rigging plates utilize threaded fasteners. The fasteners that come with each Community rigging kit are load rated to a sufficient strength to be safe when used within their specified parameters. If replacement bolts are needed, or if additional bolts are required for mounting a bracket to a beam, wall, or ceiling etc., such bolts should be purchased from a reputable manufacturer with a minimum Grade 5 rating. On hex-head bolts this can be readily identified by looking at the head. A Grade 5 bolt will be marked with three lines; a Grade 8 bolt, which is even stronger, with six lines. Allen drive fasteners are often made of high-strength steel (Grade 5 or better) if they are purchased from an industrial supplier. As with any other rigging component, check the rating on the box or the manufacturer's specification sheet to be sure.

## 10. Support Points & General Practices

A vital part of planning the mounting or suspension system is to first determine the strength of the building's support points. Nothing should be assumed, even for the lightest loads. A ten pound loudspeaker falling from ten feet can maim or kill just as readily as a heavy loudspeaker array falling from thirty feet. The services of a registered structural or professional engineer should be employed to determine if the materials and design of the supporting structure are adequate to support the intended load, and how to best install mounting brackets or derive suspension points.

### Fabric Webbing, Slings, and Spansets

Fabric webbing, fabric slings, and polyester Spansets can be very useful to the rigger. They are strong, lightweight, and do not have stray wires on their ends that can cut fingers like wire rope slings. They're particularly useful as a means of securing a personal safety device such as a climbing harness, when working at elevation. That said, be cautious of using them in permanent installations as they are far more prone to damage by fire than their steel counterparts.

### Fasteners

As a general rule, lag bolts driven into wooden beams should be avoided whenever possible, as they can pull out as the wood ages or swells due to changes in temperature and humidity. Safe riggers will instead utilize machine bolts of Grade 5 ratings or higher, rated beam clamps, brackets fabricated and welded by certified welders, wire rope wrapped around beams with cushioning materials, and so on.

Certain wooden beams, or trusses, made of many laminations (often called Glue Lams) are intolerant of holes. These beams are commonly used in modern construction, particularly in tilt-up concrete industrial buildings. Drilling a hole through such beams can set up internal fractures, resulting in total failure of the beam. Alternatives to drilling include fabricating steel brackets to surround the beam, or wrapping the beam with a steel sling and fabric cushions, to derive a hang point.

Concrete expansion bolts, such as Hilti Kwik-bolts or equivalent, can provide an excellent means of attaching moderate loads to concrete surfaces. However, as they rely on an expanding wedge to obtain their strength, they must always be used in strict accordance with the manufacturer's instructions. Such instructions specify the diameter and depth of the hole, the composition of the concrete, permissible spacing of the anchors, and the torque of the bolts. As a general rule, they should only be used for shear loads, not tension loads.

## 11. Liability

When you install a loudspeaker that is mounted or suspended over people's heads, it is your responsibility and yours alone to insure that the installation is performed in a safe manner. Never take the word of someone who tells you, "That beam is safe to drill into," or "This point can handle the load," or "I'll take responsibility if anything happens." To paraphrase Harry Donovan from his excellent book on safe rigging practices entitled Entertainment Rigging, 'How is it going to sound to the jury at your manslaughter trial when you use such statements by others as your defense?'

Never do anything you aren't 100% sure is safe. If a manufactured product looks poorly designed and built, it probably *is* poorly designed and built. If you aren't absolutely sure where the wire rope came from or how strong it is, don't touch it. If the bolt looks too flimsy to hold the load, it probably *is* too flimsy. Always use your best judgment, just as you do when driving at high speeds in traffic. The life you save may be your own.

# S-SERIES RIGGING AND MOUNTING HARDWARE

Below are descriptions of mounting brackets and suspension kits manufactured by Community for use with S-Series loudspeakers. In this section the terms "suspension" and "fly" mean the same thing: to elevate the loudspeaker enclosure above the ground surface.



**IMPORTANT:** All rigging fittings should remain sealed, otherwise air leaks will occur in the enclosure that can compromise the low-frequency performance with distortion and reduced output.



**WARNING:** S-Series rigging fittings are rated at a Working Load Limit of 100 lbs (45.4kg) with a 10:1 safety margin. No single rigging fitting should ever be subjected to a load that is greater than 100 lbs. Failure to heed this warning could result in injury or death!

## 1. *Seat Track Kit: STKIT*

A Seat Track Kit is available that fits all models of S-Series full-range loudspeakers. Designated the **STKIT**, the kit provides a safe and convenient means of suspending a single enclosure.

By purchasing multiple kits, one enclosure may be safely suspended over another.

Both M10 *Metric* and 3/8-16 *Unified Course (UNC)* threaded fasteners are included with each STKIT. Because these fasteners have nearly identical threads, it is critically important that you use fasteners with the proper thread pitch for the S-Series of loudspeakers. The proper fasteners are the M10 *metric* fasteners. Do not use the 3/8-16 UNC fasteners.



All parts in the kit are engineered to provide a high margin of safety. Each Seat Track Channel is load rated at 350 lbs with a 15:1 Safety Factor. The channels are manufactured of milled high-strength aluminum and are anodized black. (However, the highest weight to consider at any one point is the weakest link – the threaded insert.)

No hardware is provided to attach to the fittings in the Seat Track Kit. Such hardware must be supplied by the installer, and should be rated for the weight load of the enclosure(s). If multiple enclosures are suspended one above the other, it is the installer's responsibility to insure that the combined weight load does not exceed the Working Load Limit on any one rigging fitting. This is particularly important if the enclosures are angled downward, as most or all of the weight may be supported by the rear points only.

Hardware fittings that mate with the Seat Track Channel are available from numerous entertainment rigging suppliers. Be sure to purchase or specify only such fittings that are rated for use overhead. The installer is solely responsible for determining if all rigging components that are used to suspend the enclosure(s) are adequately sized and rated, and if the structure they are suspended from is capable of safely supporting the aggregate weight load of the enclosure(s).

### **STKIT Parts List**

Aluminum Seat Track Channels (4)  
8 x 1" Flathead Phillips Drive Deep Thread Screws (4)  
M10 x 40mm Flathead Allen Drive Screws (4)  
3/8-16 x 1.5" UNC Flathead Allen Drive Screws (4)

*The installer must supply all other hardware for the installation.*

## STKIT Assembly Instructions



**CAUTION:** Before assembling the Seat Track Channels to the loudspeaker enclosure, note that the kit is supplied with both 3/8-16 *Unified Course* and 10mm *Metric* fasteners. These fasteners are very similar but they are NOT identical. It is critically important that you use fasteners with the proper thread pitch. All S- Series loudspeakers use the M10 *metric* fasteners. DO NOT USE THE 3/8-16 UNC FASTENERS! It is very easy to mistake one thread pitch for the other.

1. To assemble the Seat Track Channel to the loudspeaker enclosure, first remove the factory supplied flat-head Allen screws from the top of the enclosure.
2. Next, place a Seat Track Channel over each rigging fitting in the enclosure. Orient the Seat Track Channel so that it is not overhanging the edges of the enclosure, and align it so that it's parallel to the enclosure side (see Figure 15). Using a fastener with the proper thread pitch, thread each fastener into the rigging fitting in the enclosure until it is finger-tight. If a fastener does not thread easily into the fitting in the enclosure, it may be of the wrong thread pitch. Do NOT force it with a wrench! Check the threads to make sure they are correct. You can do this by comparing the supplied fastener to the one that you removed from the enclosure. If the threads are identical, you will not be able to see any light between them when they are nested together. If you can see any light at all between the two fasteners when the threads are placed next to each other, they are not identical!



**DANGER:** Use of the wrong threaded fastener will result in thread failure under load, which can cause damage to property, serious injury, or death.

3. Tighten each fastener to a torque of 15 foot-lbs using a torque wrench. Do not overtighten.  
**Note:** Allen wrenches with 3/8" and 1/2" socket fittings, designed to attach to a ratchet or torque wrench, are readily available at tool stores.
4. Now, using an electric screwdriver, insert one 8 x 1" flathead Phillips screw into each of the small holes in the Seat Track Channels. Tighten until snug. Be careful not to overtighten, as the screw will break under too much torque. The purpose of these smaller screws is only to keep the Seat Track Channel from rotating under load.
5. After attaching appropriate mating hardware to the Seat Track Channels, you can now lift the enclosure a foot or two off the ground. Check to make sure all fasteners are tightened securely, and then bring the enclosure to trim height.

### Using More Than One Enclosure

Additional Seat Track Kits may be used to suspend one enclosure over another. This is accomplished by attaching one set of Seat Track Channels to the bottom of the upper enclosure, and a second set of Seat Track Channels to the top of the lower enclosure.

The two enclosures may then be joined together by using various hardware fittings that mate to the Seat Track. Such hardware includes swivel fittings, tandem swivel fittings, and other mating devices that are readily available from theatrical rigging suppliers.



**CAUTION:** Be sure that all mating hardware used to suspend the enclosure(s) is specifically rated for overhead use and capable of supporting the weight load of the enclosure(s) with an adequate Safety Factor. Some hardware fittings are NOT rated for overhead use, but look very similar to those that are. Check with the manufacturer or supplier to be sure.

If multiple enclosures are suspended one above the other, it is the installer's responsibility to insure that the combined weight load does not exceed the 100 lb Working Load Limit of any one rigging fitting. This is particularly important if the enclosures are angled downward, as most or all of the weight will be supported by the rear points only.



**Figure 15: STKIT Assembly of S-Series Enclosure with 4 Seat Track Channels and M10 Hardware**

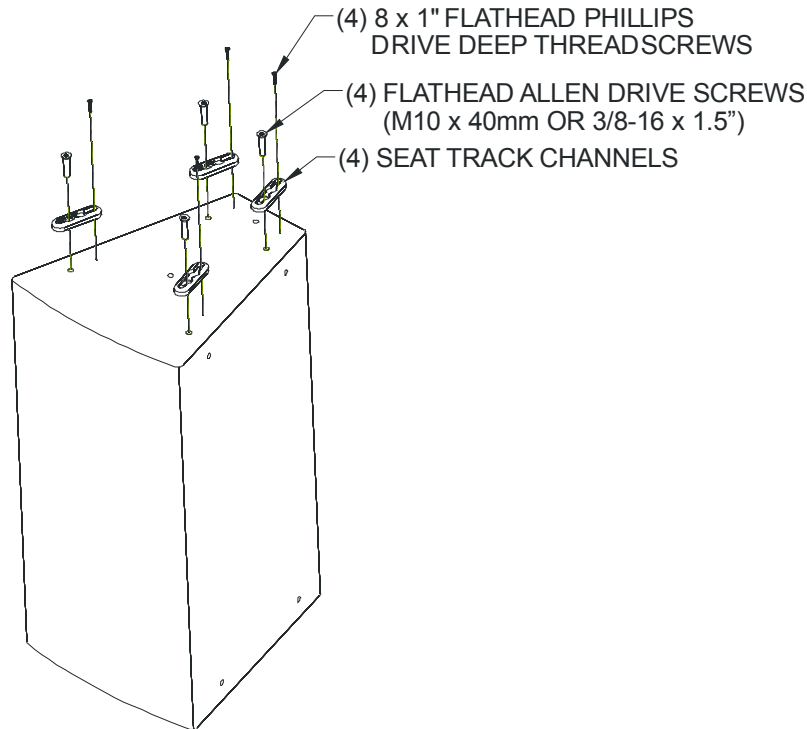

**IMPORTANT SAFETY WARNING:** The STKIT is supplied with both 3/8-16 *Unified Course* and 10mm *Metric* fasteners. These fasteners are very similar but they are NOT identical. It is critically important that you use the M10 fasteners with all S- Series enclosures. **DO NOT USE THE 3/8-16 UNC fasteners under any circumstances. Use of fasteners with the incorrect thread pitch could result in serious harm, injury or death, because the threads will not hold securely under load.**

## ***2. Vertical Fly Kit: VFKIT***

A Vertical Fly Kit, designated the **VFKIT**, is available to fit the trapezoidal full-range S-1596, S-3294 and S-3594 loudspeakers.

The kit consists of two flat steel plates, slotted to align with the S-Series rigging fittings on the tops and bottoms of the enclosures, and four eyebolts. It allows a pair of S-Series enclosures to be flown in a horizontal splayed-array orientation.

Three, four, or more S-Series enclosures may be flown by purchasing additional Vertical Fly Kits; two kits will fly three enclosures, three kits will fly four enclosures, and so on.

All parts in the kit are engineered to provide a high margin of safety when used with S-Series loudspeakers. The brackets are manufactured of steel and covered with a durable powder-coat finish.

No hardware is provided to attach suspension cables to the Vertical Fly Kit. Such hardware must be supplied by the installer, and should be rated for the weight load of the enclosures. The installer is solely responsible for determining if all rigging components that are used to suspend the enclosures are adequately sized and rated, and if the structure they are suspended from is capable of safely supporting the aggregate weight load.

### **VFKIT Parts List**

- (1) Front Metal Bracket
- (1) Rear Metal Bracket
- (4) M10 30mm Bolts
- (8) M10 Flat Washers
- (8) M10 Split Lock Washer
- (4) M10 Eyebolts
- (4) M10 Hex Nuts

*The installer must supply all other hardware for the installation.*

## **VFKIT Assembly Instructions**

1. First, remove the two factory supplied flat-head Allen screws on the *inside tops* of each enclosure (4 total).
2. Assemble the components of the Vertical Fly Kit as shown in the drawing below. Attach the Front Metal Bracket to the front of the enclosures using two M10 x 30mm bolts fitted with lock washers and flat washers. At this time do not fully tighten the bolts.
3. Next, attach the Rear Metal Bracket to the rear of the enclosure, again using two M10 x 30mm bolts fitted with lock washers and flat washers.
4. Now, position the enclosures so that their rear corners are touching and lined up evenly with each other. Tighten the bolts to a setting of 10 to 12 foot-lbs using a torque wrench. Do not overtighten!

**Figure 16: VFKIT Vertical Fly Kit Assembly**

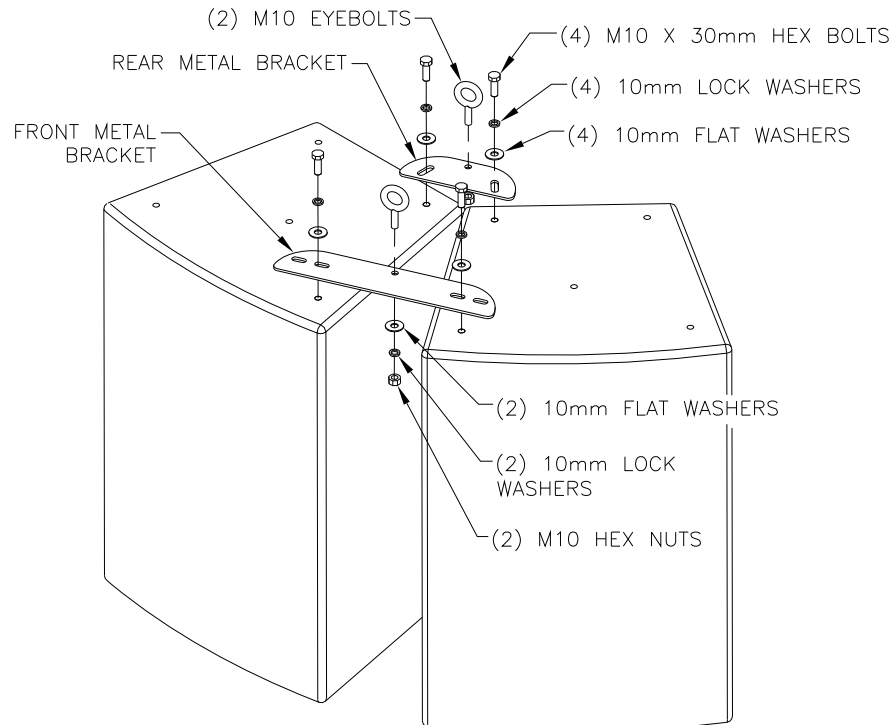

## **VFKIT Rigging Instructions**

1. The Vertical Fly Kit should be rigged from both the front and rear points using appropriate load-rated hardware. After rigging, lift the loudspeakers about two feet off the ground. Carefully inspect the rigging to make sure that no shackles are twisted and that all fasteners are tightened properly.

2. The use of safety points in rigged or 'flown' systems is highly recommended. The Vertical Fly Kit includes eyebolts intended for this purpose. The eyebolts should ideally be attached to unused rigging fittings on the tops of the enclosures and connected to safety cables. Safety cables are a second set of 'backup' cables that can sustain the load in the event that the primary suspension system fails. Safety cables must always be installed with little to no slack. A slack safety cable will result in a serious shock load to the cable and the rigging hardware if the primary rigging fails. Such a shock load could cause the safety cable or other rigging components to fail as well.
3. After the primary rigging and the secondary safety cables have been attached, the loudspeaker array is now ready to be raised to its proper trim height.
4. Two threaded rigging fittings are provided on the rear of each enclosure. These fittings are intended to be used as pull-back points, if a steep angle of downward inclination is required. They are not intended to be used as the primary rigging points to suspend the enclosures.

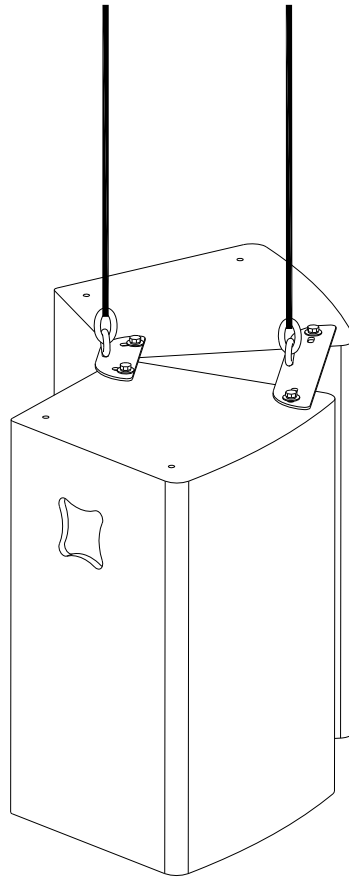

**WARNING:** Never reeve a primary support cable or a safety cable through a pair of eyebolts or shackles (see drawing below). When a cable or sling is reeved through a pair of eyebolts, it will load the eyebolts both laterally and vertically with a vector force that greatly exceeds the actual weight of the loudspeaker array. The proper solution is to provide separate cables for each one of the eyebolts.

**Figure 17: Never Reeve Cables!**

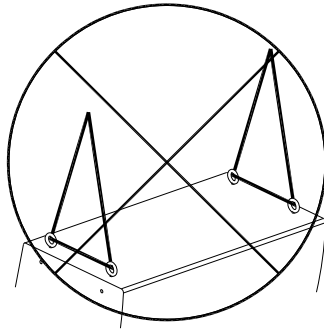

## Using More Than One VFKIT

More than one Vertical Fly Kit may be used to fly three, four, or more loudspeakers in an array. Simply attach the additional kit(s) to the additional enclosures in the same manner as the first kit.



**WARNING:** When assembling more than two enclosures into an array, it is very important that the suspension cables be installed correctly so as not to place undue stress on either the Vertical Fly Kit or on the enclosures themselves. The following rigging guidelines must be observed explicitly:

### Rigging Three Enclosures

When three enclosures are flown, **both of the front** and **both of the rear** hang points must be used. In other words, two suspension cables or slings must attach to the front hang points and two cables or slings must attach to the rear hang points, forming two low-angle bridles as shown in Figure 18 below. Note that every enclosure has at least two live hang points attached to it.

**Figure 18: Rigging Three Enclosures with the VFKIT**

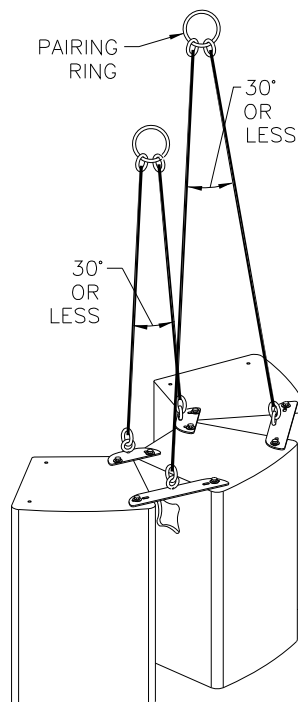

It is also permissible to bridle from the front to rear hang points, using a separate bridle for each enclosure. This may have to be done if the hang points in the building are oriented left-to-right instead of upstage/downstage. However, setting the bridles for an upstage/downstage hang, as shown above, provides the advantage of being able to adjust the inclination of the array while it's in the air. Setting the bridles for a left and right hang introduces the issue of having to exactly match the length of the cables to avoid a lopsided hang. Note that every enclosure has at least two live hang points attached to it.



**WARNING:** The angle of the bridles should be 30 degrees or less to stay within a reasonable safety margin. **Under no circumstances should the bridle angle ever exceed 45 degrees, or failure to one or more rigging parts may occur. Lower bridle angles put less stress on the rigging components and are always safer!**



**WARNING:** Never reeve a Spanset, sling, wire rope or webbing through a shackle or hook at the upper hang point. The legs of any bridle must always be separate parts, joined by a shackle or a pairing ring. If a single part is reeved through a shackle or hook, there is nothing to stop the load from becoming unbalanced and turning sideways in the air. Moreover, the point on the sling where it contacts the metal shackle or hook will bear twice as much load if it's reeved, than if it's a single part.

## Rigging Four Enclosures

When four enclosures are flown, the *two outermost front* and *two outermost rear* points must be used (four points total). The bridles may be run from the front to the rear points, or they may be run from one outer rear point to the opposite outer rear point, and the same for the outer front points. Bridling across the front points and the rear points, which results in an upstage/downstage hang, provides the advantage of being able to adjust the inclination of the array after it's flown. Note that every enclosure has at least two live hang points attached to it.

**Figure 19: Rigging Four Enclosures with the VFKIT**

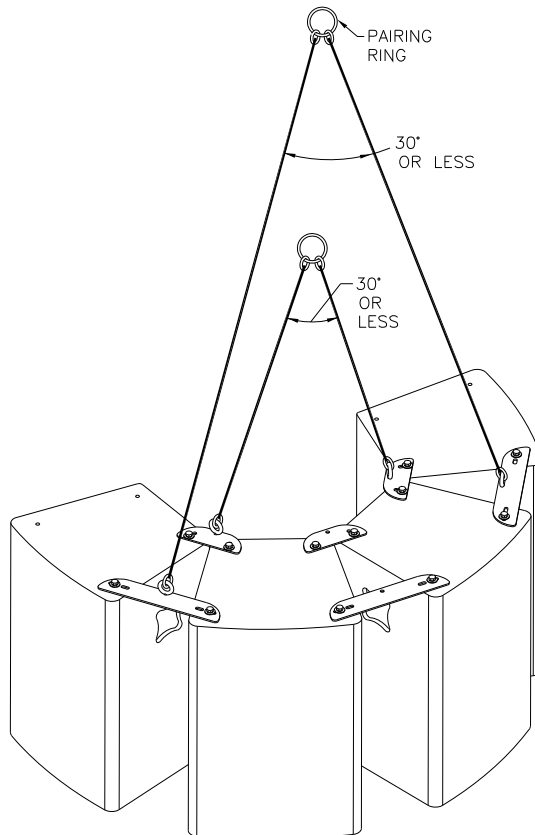

# AVAILABLE ACCESSORIES

In addition to the rigging kits described above, these other useful accessories are available for S-Series loudspeakers:



## Padded Transport Covers

Protect your S-Series loudspeakers from scratches and marks.

- Part # CVR-S12 (S-1296 loudspeaker cover)
- Part # CVR-S15 (S-1596 loudspeaker cover)
- Part # CVR-S32 (S-3294 loudspeaker cover)
- Part # CVR-S35 (S-3594 loudspeaker cover)
- Part # CVR-S215S (S-215S loudspeaker cover)
- Part # CVR-S218S (S-218S loudspeaker cover)



## SB5 Support Stand

Elevates a full-range loudspeaker using the subwoofer as the base. Pole is 5' x 1 $\frac{3}{8}$ " steel with a black finish. Part # SB5.



## Eyebolt Kit

Suspend your S-Series loudspeakers safely and easily. Four eyebolts and four cup-washers included. Part # M10EYBLTKIT.



# SERVICING S-SERIES LOUDSPEAKERS

Servicing a S-Series loudspeaker is straightforward and easy. All drivers are serviceable by removing the screws that attach the protective grille to the front of the enclosure. The crossover is serviceable by removing the input panel on the rear of the enclosure. There are no other user-serviceable parts.

## TROUBLESHOOTING GUIDE

Should you have a problem with your S-Series loudspeaker(s), find the symptom and follow the associated "What To Do" instructions below. Be aware that a particular symptom may have several possible causes.

SYMPTOM	PROBABLE CAUSE	WHAT TO DO
High distortion, low output, or no output from any or all drivers.	Faulty connection to the loudspeaker.  Possible solder joint failure on crossover card.	Using an ohmmeter, check the continuity of the wiring to the loudspeaker. If the wiring is OK, remove the input panel and check all solder joints on the crossover and the wiring to the drivers. Visually inspect solder joints as cold joints may only malfunction under high current. Repair as needed.
Distortion from the loudspeaker at higher volume levels.	Too little amplifier power.	If the power rating of the amplifier is too low, it will clip at higher volume levels. Reduce the volume level or use a more powerful amplifier.
Distortion from the loudspeaker at moderate to high volume levels.	Driver is malfunctioning.	Using a sine wave oscillator or wide range program at moderate levels, listen to each driver to isolate the problem. Replace as needed.
In BI-AMPLIFIED mode bass is weak or non-existent, and highs sound "muffled".	Wiring for LF and HF sections is reversed from electronic crossover or amplifier.	Check wiring from crossover to amplifier, and amplifier to loudspeaker. Make sure the HF amplifier channel is connected to the HF driver and the LF amplifier channel is connected to the LF driver.
Low or no output from the low-frequency driver.	Low-frequency driver, crossover, or amplifier is malfunctioning.	Test and replace as needed.
Low or no output from the low-frequency driver.	Mis-wired NL4-compatible locking connector.	Check wiring and correct as needed.
Low or no output from the mid-frequency driver (applies to 3294 and 3594 only).	Mid-frequency driver, crossover, or amplifier is malfunctioning.	Test and replace as needed.
Low or no output from the mid-frequency driver.	Mis-wired NL4-compatible locking connector.	Check wiring and correct as needed.
Low or no output from the high-frequency driver.	High-frequency driver, crossover, or amplifier is malfunctioning.	Test and replace as needed.
Low or no output from the high-frequency driver.	Mis-wired NL4-compatible locking connector.	Check wiring and correct as needed.
Low volume level.	System gain is too low.	Check to make sure that the audio signal to the amplifier is high enough to drive it properly. Check all volume/level controls and gain switches in the system including the amplifier input attenuator.

<b>SYMPTOM</b>	<b>PROBABLE CAUSE</b>	<b>WHAT TO DO</b>
Low volume level.	Signal or speaker wire connection is shorted.	Make sure the signal and input wire connections inside all system connectors are not shorted or open. Even one small wire strand shorting the +/- signal terminals together anywhere in the system can cause this problem.
Sound when BI-AMPLIFIED is "muffled".	PASSIVE / BI-AMP switch is in the wrong position.	Switch on the input panel should be in the BI-AMP MODE (RIGHT) position.
Mid and high frequencies "muffled" or missing in PASSIVE mode.	PASSIVE / BI-AMP switch is in the wrong position.	Switch on the input panel should be in the PASSIVE mode (LEFT) position.
No low frequencies in PASSIVE mode.	PASSIVE / BI-AMP switch is in the wrong position or the wrong connector pins are being used.	Check that the switch is in the PASSIVE (LEFT) position and that you are using connector pins #1 +/-.
No mid or high frequencies in BI-AMPLIFIED mode.	HF amplifier is not functioning or loudspeaker is disconnected.	Check that the HF amplifier is turned on and that the loudspeaker is properly connected to the amplifier.
No mid or high frequencies in BI-AMPLIFIED mode.	HF section of electronic crossover is not functioning or is disconnected.	Check that any external electronic crossover has HF output and that it is properly connected to the amplifier.
No sound.	Amplifier is not on or loudspeaker is disconnected.	Check that amplifier is turned on and that loudspeaker is properly connected to the amplifier.
No sound in PASSIVE mode.	Wrong pins are wired on the speaker connector.	Make sure you are using connector pins #1 + / -.
No sound or very low volume.	No audio signal.	Check that all the audio equipment in the signal chain is powered on and that all gain controls are in the proper position.
Noises from the loudspeaker (buzzes or rattles).	Grille or hardware is loose.	Make sure the front grille screws are securely seated and that any external mounting hardware is tightened or secured from vibrating.
Noises from the loudspeaker (buzzes or rattles).	Driver is malfunctioning.	Using a sine wave oscillator or wide range program at moderate levels, listen to each driver to isolate the problem. Replace as needed.
Poor sound quality in BI-AMPLIFIED MODE.	Incorrect connections / reversed polarity.	Check the connections to the LF and HF sections. Verify that polarity is correct (+ and - amplifier outputs go to + and - on all connectors and on the loudspeaker).
Sound cuts in and out.	The crossover protection circuits have been activated.	This usually means that the loudspeaker is being constantly overdriven and the crossover protection circuits are reducing the power to the loudspeaker as a protective measure. Reduce the volume level to the loudspeaker.
Sound cuts in and out.	Bad connection.	Check all connections and cabling for shorts or loose connections. Even one small wire strand shorting the +/- signal terminals anywhere in the system can cause this problem.
Sudden 3 dB loss in sound.	The crossover protection circuits have been activated.	This usually means that the loudspeaker is being constantly overdriven and the crossover protection circuits are reducing the power to the loudspeaker as a protective measure. Reduce the volume level to the loudspeaker.



# REPLACEMENT PARTS

The following replacement parts may be ordered through authorized Community Service Stations. Please contact Community for your nearest Service Station.

<b>S-1296</b>	
Part Number	Description
108920R	SPEAKER, 12"
UC1	HF DRIVER UC-1
108190R	HORN, HF S-SERIES 12/15"
109003R	CROSSOVER S -1296
109532R	GRILLE, S--1296 W/HARDWARE
FOOTKIT	RUBBER FOOT KIT (4)

<b>S-1596</b>	
Part Number	Description
108921R	SPEAKER, 15"
UC1	HF DRIVER UC-1
108190R	HORN, HF S-SERIES 12/15"
109004R	CROSSOVER S-1596
109533R	GRILLE, S-1596 W/HARDWARE
FOOTKIT	RUBBER FOOT KIT (4)

<b>S-3294</b>	
Part Number	Description
108920R	SPEAKER, 12"
105654R	SPEAKER, 6.5", MID-FREQUENCY
UC1	HF DRIVER UC-1
109071R	HORN, HF S-SERIES 32/35"
109002R	CROSSOVER S-3294/3594
109534R	GRILLE, S-3294 W/HARDWARE
FOOTKIT	RUBBER FOOT KIT (4)

<b>S-3594</b>	
Part Number	Description
108921R	SPEAKER, 15"
105654R	SPEAKER, 6.5", MID-FREQUENCY
UC1	HF DRIVER UC-1
109071R	HORN, HF S-SERIES 32/35"
109002R	CROSSOVER S-3294/3594
109535R	GRILLE, S-3594 W/HARDWARE
FOOTKIT	RUBBER FOOT KIT (4)

<b>S-215S</b>	
Part Number	Description
106475R	SPEAKER, 15-INCH SUB AIRFLOW
108631R	CROSSOVER S-215S
109536R	GRILLE, S-215S W/HARDWARE
FOOTKIT	RUBBER FOOT KIT (4)
105315R	KIT, STAND SOCKET 1-3/8

<b>S-218S</b>	
Part Number	Description
106105R	SPEAKER, 18-INCH AIRFLOW
109957R	CROSSOVER S-218S
109537R	GRILLE, S-218S W/HARDWARE
FOOTKIT	RUBBER FOOT KIT (4)
105315R	KIT, STAND SOCKET 1-3/8

## SUMMING THINGS UP

S-Series loudspeakers and accessories are intelligently designed to provide you with effective solutions for common and not-so-common sound reinforcement problems. These great-looking and superb-sounding building blocks can be utilized in a wide variety of ways. By giving careful consideration to your application needs, and taking the time to properly position, focus, adjust, and equalize your system, S-Series products will provide years of satisfying service. If questions or special needs arise at any time, the professional staff at Community will be happy to offer experienced technical advice to assist you.



# WARRANTY INFORMATION AND SERVICE

## Transferable Warranty (Limited) – Valid in the USA Only

Community loudspeaker systems are warranted in the USA to be free from defects in materials and workmanship for a period of five years, as determined by one of the following two methods, whichever is longer:

1. Starting from the date of retail purchase, as noted on the sales receipt from an authorized Community dealer,

OR

2. Starting from the date of manufacture, determined by the serial number, if the sales receipt is not available.

This warranty applies to the product; therefore, the remainder of the warranty period will be automatically transferred to any subsequent owner.

This warranty applies only to failure of a Community loudspeaker caused by defects in materials and workmanship during the stated warranty period. It does not apply to a unit that has been subjected to abuse, accident, modification, improper handling/installation, or repairs made without factory authorization or by anyone other than authorized Community Field Service Stations. This warranty is void if the serial number has been defaced, altered or removed.

Products covered by this warranty will be repaired or replaced at the option of Community, without charge for materials or labor, provided all the terms of this warranty have been met.

## Obtaining Warranty Service

Warranty service may be obtained from the factory, or from an authorized Field Service Station.

To obtain factory or field warranty service for products purchased in the United States, return the product for inspection to the address below, freight prepaid, in the original packaging. If the original packaging is not available, call or write Community Warranty Service to obtain proper packaging materials or hand carry the product to the nearest Field Service Station.

*Factory Service Center:*  
Community Warranty Service  
333 East Fifth Street  
Chester, PA 19013-4511 USA

*Field Service Station:*  
Call (610) 876-3400 for the nearest Authorized Field Service Station

For factory service, please call (610) 876-3400 for a Return Authorization (R/A) number before shipping. The following information must be included in the package:

1. Owner's complete name, daytime phone number, return street address and return authorization number.
2. The serial number of the product being returned and a copy of the retail sales receipt, if possible.
3. A complete description of the problem(s) experienced, including a brief description of how the equipment is being used and with what brand, model and output power of amplifier.

Upon receipt, the service center will determine if the problem is covered under warranty. If covered under this warranty, the product will be repaired or replaced, at Community's option, and returned to the owner freight prepaid. If the problem is not covered under this warranty, the owner will be notified of the problem with an estimate of the repair costs.

Consequential and Incidental Damages: Community shall not be liable for any consequential or incidental damages including, without limitation, injury to persons, property, or loss of use. Some states do not allow

the exclusion or limitations of consequential or incidental damages, so the above limitations and exclusions may not apply.

This Community warranty is not extended by the length of time which an owner is deprived of the use of the product. Repairs and replacement parts provided under the terms of this warranty shall carry only the remaining portion of the warranty.

Community reserves the right to change the design of any product from time to time, without notice and with no obligation to make corresponding changes in products previously manufactured.

While this warranty gives specific legal rights, there may also be other rights that vary from state to state. No action to enforce this warranty shall be permitted ninety days after expiration of the warranty period.

### **Warranty Information and Service For Countries Other Than The USA**

To obtain specific warranty information and available service locations for countries other than the United States of America, contact the authorized Community Distributor for your specific country or region.



Community Professional Loudspeakers  
333 East Fifth Street, Chester, PA 19013-4511 USA  
Tel: 1-(610) 876-3400 | Fax: 1-(610) 874-0190  
[www.communitypro.com](http://www.communitypro.com)

© 2008 All Rights Reserved