

Community

S-SERIES

S-1296

TWO-WAY FULL-RANGE LOUDSPEAKER SYSTEM

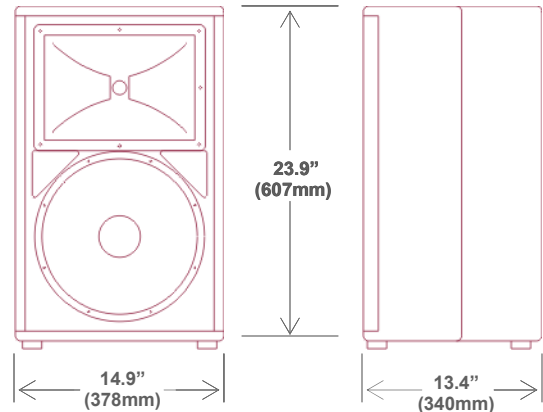

Description

The S-1296 is a two-way, ruggedly built full-range loudspeaker system, suitable for both portable use and fixed installations.

Compact, but extremely powerful, the S-1296 handles applications ranging from clubs and AV presentations, to rock and roll performances.

Its multi-angle design allows it to function equally well as a Stage Monitor or a Front of House system. As a stage monitor, the performer has a choice of 90°, 125° and 145° angles of inclination from the stage floor. When used as a FOH system, the enclosure may be flown from its M10 threaded rigging points, supported on a stand, or ground supported.

Utilizing advanced technologies normally found only in high priced touring systems, the S-1296 provides extended high frequency response, low distortion output, and precise pattern control.

Featuring carefully designed crossovers that provide flat acoustic power response throughout the critical mid-range region, and Community's exclusive DYNA-TECH™ dynamic driver protection circuitry, the S-1296 is a versatile performer well suited for use by professional audio rental companies, touring musicians, and others requiring high quality sound reinforcement at an affordable price.

Applications

- Stage Monitoring
- Nightclubs
- Theatres
- Sound Stages
- AV Presentation

Features

DYNA-TECH™
Dynamic Protection

Switchable Bi-amp /
Single-amp Operation

Switchable Music /
Speech Voicing

Ferrofluid Treated
HF Driver for Improved
Heat Transfer

Non-Resonant, Non-
Metallic HF Diaphragm
for Reduced Distortion

Carbon Ring Cone
Technology Provides
30% More Piston Area
with Increased Excur-
sion Capability

Dual NL4 and Dual
1/4" Input / Output
Connectors

SYSTEM

Format: Two-way full-range, vented bass - switchable passive or bi-amp x-over

Operating Range: 60 Hz - 20 kHz

Frequency Response: 100 Hz - 16 kHz (±4 dB)

Dispersion (-6 dB): 90° H x 60° V (in vertical position)

Maximum SPL @1m: 122 dB continuous / 129 dB peak

Crossover Frequency: 1.5 kHz

Sensitivity in SPL: 99 dB (100 Hz - 10 kHz, 1/3 octave)
99 dB (250 Hz - 4 kHz, speech range)

Max Power Handling: 200W RMS
(passive mode) 500W Program / 990W Peak

Impedance (passive): Nominal 8Ω / Min. 4Ω at 10.6 kHz

TRANSDUCERS

Low Frequency: 12" (304mm) 200W RMS
500W Program, 8Ω

High Frequency: 1" (25.4mm) 50W RMS
125W Program, 4Ω

MECHANICAL

Enclosure: Multi-angle (90°, 125°, and 145°)
11-ply cross-laminated birch

Finish: Black catalyzed polyester paint

Rigging Provisions: Eight M10 threaded rigging fittings*
(three on top, three on bottom,
two on rear)

Grille: Steel, powder coated black

Dimensions: 23.9" (607mm) x 14.9" (378mm) x
13.4" (340mm)

Net Weight: 36 lbs / 16.3 kg

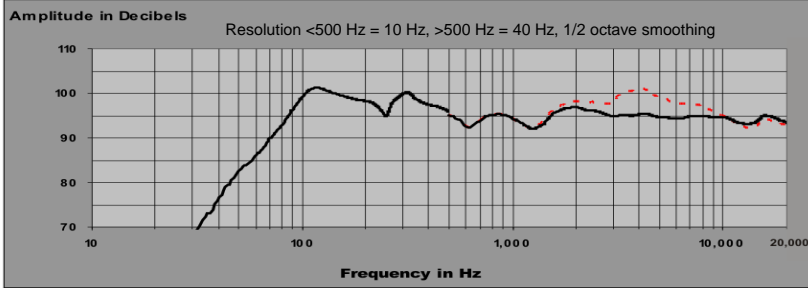

FREQUENCY RESPONSE

Note: Response may be altered by use of *Presence Switch*. The solid black line depicts the MUSIC position; the dotted red line depicts the SPEECH position.

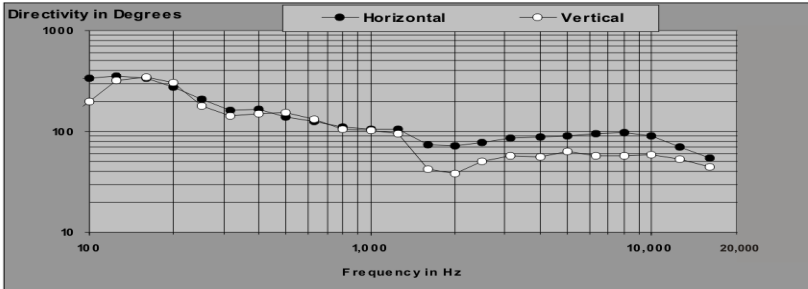

BEAMWIDTH

Note: Indicates Horizontal and Vertical Directivity Index in Degrees vs. Frequency.

Recommended Power: 300 to 625 WRMS¹ at 8Ω

Recommended High-Pass Filter: 60 Hz, 24 dB/octave

¹WRMS = Watts Root Mean Square

Accessories



Padded Transport Covers
Protect your S-Series loudspeakers from scratches and mars.
Model CVR-S12



Eyebolt Kit
Suspend your S-Series loudspeakers safely and easily.
Model M10EYBLTKIT

Support Stand
Elevates a full-range S-Series loudspeaker using the subwoofer as the base.
Model SB5

Vertical Fly Kit

One kit lets you fly two S-Series enclosures in a splayed array; two kits let you fly three enclosures, and so on. **Model VFKIT**



Seat Track Rigging Kit

The quick-release fittings get your S-Series enclosures up in the air and back down again, quickly and safely.
Model STKIT



Community Professional Loudspeakers, 333 East Fifth Street, Chester, PA USA 19013-4511
TEL: 610-876-3400 • FAX: 610-874-0190 • www.communitypro.com