

# PLUSH FX PEDALS

®

## *"REP-3 Tube-Voiced Delay"*



V 1.1 (27-August-2012)

## Operations Manual

**Plush division of Fuchs Audio Technology**

407 Getty Ave

Clifton, NJ 07015

(973) 772-4420 (fax) 973-772-4460

Website: [www.plush-pedals.com](http://www.plush-pedals.com)

Email: [info@fuchsaudiotechnology.com](mailto:info@fuchsaudiotechnology.com)

© 2000-2008 Fuchs Audio Technology. All rights reserved.

# PLUSH FX PEDALS

**REP-3** ®

## ***Table of Contents (by section)***

- 1) Introduction to The Rep-3.
- 2) Operation/applications
- 3) Block Diagram
- 4) Warranty information



©© 2000-2005 Fuchs Audio Technology. All rights reserved.

# 1 Introduction to the REP-3 Tube-Voiced Delay

First of all, **thank you** for purchasing the REP-3™!

The REP-3 Tube-Voiced Delay was designed as a replacement for old tube and solid state delay pedals. Our objective was to free the player from maintenance, the cost of replacing tapes, and to provide a simple to operate, musical platform for your musical expression. The unit is a full function unit, which can operate with pedal or rack level effects.

The REP-3 is built from the finest premium parts, and will give you years of enjoyment and high performance with no maintenance required.

Please read this manual completely, to obtain the most from your unit.

All connectors are Neutrik quality, the case is a cast aluminum enclosure with an industrial powder coat and baked on silk screening for long life and durability during use. The internal circuit boards are G-10 glass-epoxy and the circuit boards are double sided.

Enjoy The REP-3® and we hope it will give you years of playing pleasure.

Andy and Annette Fuchs  
Fuchs Audio Technology LLC

Plush Division of Fuchs Audio Technology®  
407 Getty Ave Clifton, NJ 07015  
(973)-772-4420     [www.plush-pedals.com](http://www.plush-pedals.com)     [info@fuchsaudiotechnology.com](mailto:info@fuchsaudiotechnology.com)

("Fuchs Audio Technology" "Plush" & "REPLAY JUNIOR" are registered trademarks of Fuchs Audio Technology)

## The REP Tube-Voiced Delay Specifications:

Cabinet: 4" x 7"  
Weight: 1.0 lbs  
Cabinet Material: Solid Cast Aluminum I  
covering: Industrial Grade powder coating. Heat cured silk screening.  
Circuitry: Bi-Fet Op amp, powered by dual polar supply, Tube voiced delay voicing.  
POWER: 9 VDC (ONLY) from external adaptor, or battery.

Input impedance 1-M Mix Output impedance approximately 10-K.

Delay: 32-Khz Clock 15-K Bandwidth with up to 1-Second of delay time.

## Using the Rep-3 in an effects loop:

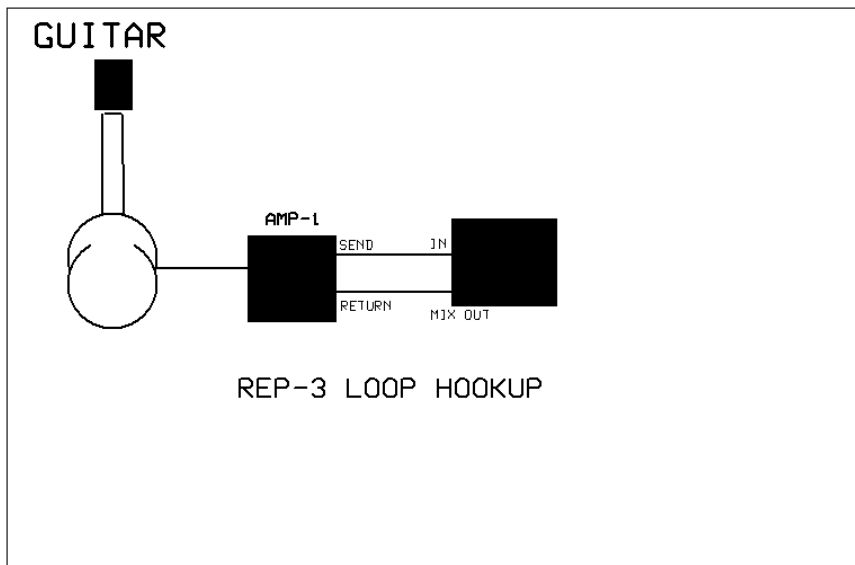

The REP-3 Delay is plugged into the amplifier effects loop, or patch (pre/power amp) or (loop) jacks. The output from the preamp (usually labeled send, or preamp out) is sent into the jack marked Input. The output from the Replay is returned to the effects loop return jack. The REP-3 has a wide dynamic range, which can be used for both line or guitar level signals.

The signal level should be monitored by the analogue meter, and the peak LED, located above the meter.

## Using the REP-3 in the front end of a guitar amp

The REP-3 be used on a pedal board, on the input of a guitar amp. In this case, it is important to make sure the amp is not used in overload or high gain mode. It is assumed the distortion would be obtained using pedals.

## Powering the REP-3 :

The REP-3 runs on 9-VDC, through an external adaptor or a 9-V battery (supplied). The pedal is intended to operate on **9-VDC only**. Exceeding this voltage or using an AC adaptor, can damage the unit, which is not covered by warranty. If you wish to power your REP\_3 from an external power supply, it must be capable of furnishing at least .060 MA of clean, ripple free DC. In some cases, the REP-

### 3 Block Diagrams

## Replay Jr Block Diagram

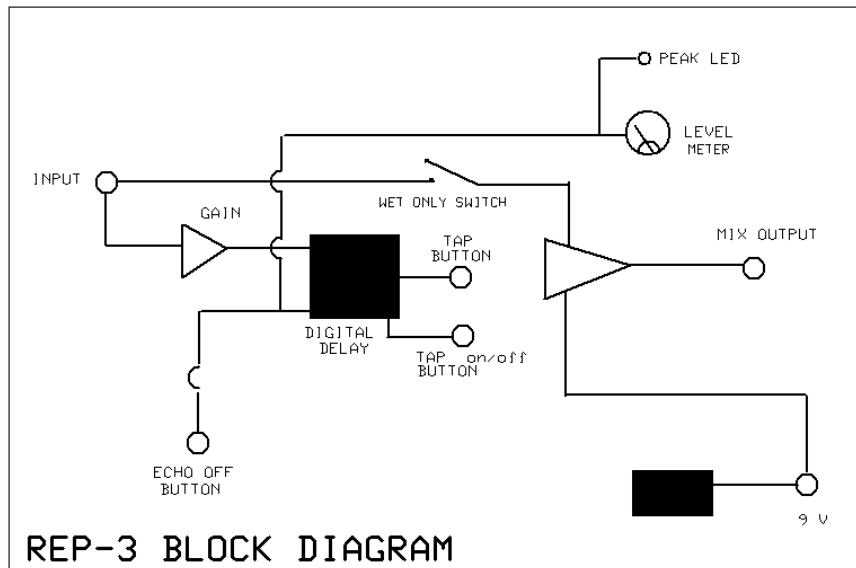

## Alternative Wiring Configuration

To run the REP-3 in a stereo configuration, open the unit, and switch the wet only switch, to wet-only position. The mix output of the Replay Jr will be delay only, and the mix knob will adjust the level of delay coming out of the unit.

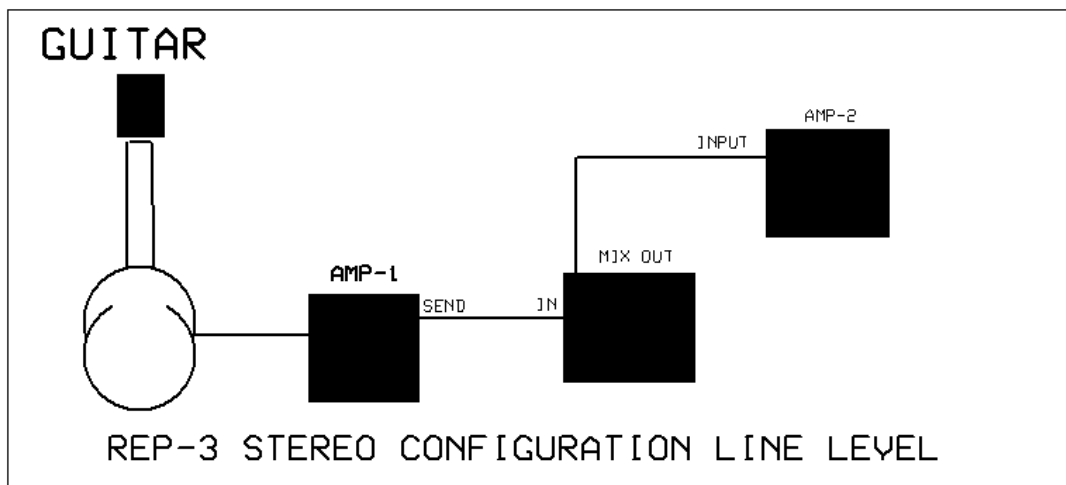

To operate the REP-3 in stereo configuration, open the unit, and switch the mix switch to wet-only position, shown below:

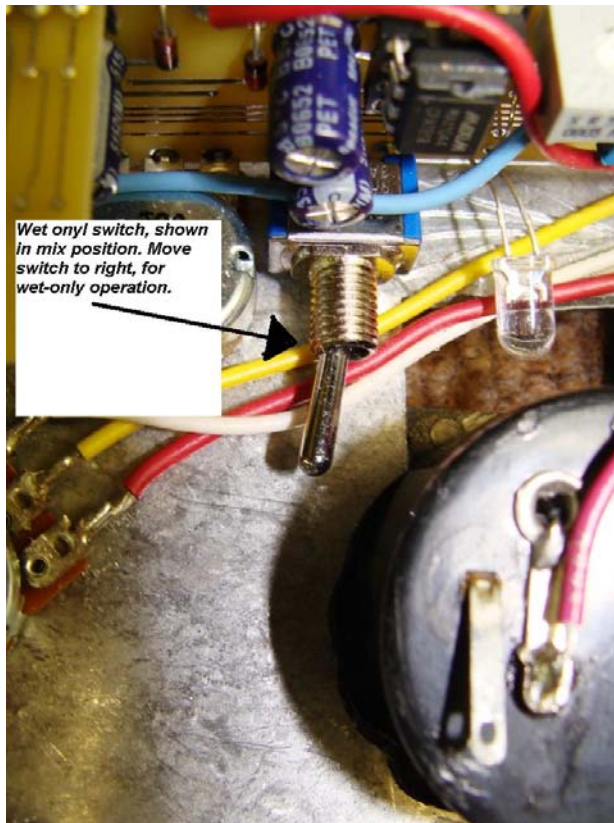

## 4 Warranty Information

### The PLUSH/Fuchs Audio Technology Warranty

In the United States, Fuchs Audio Technology® guarantees our products to be free from defective workmanship or material failure for a period of FIVE years (tubes excluded) from date of new purchase to the original purchaser. Outside of the United States, the warranty is based on each country's local laws and distributor's policies. Contact your local dealer or distributor for details. This does not apply to Fuchs amplifiers or pedals that have been tampered with, damaged by shipping carriers, reverse engineered, or modified. Your warranty form/information must be returned to Fuchs Audio Technology® within 30 days of purchase, or your warranty will not be in effect. Fuchs Audio Technology® reserves the right to suspend or terminate the above warranty at our sole discretion, should damage from any of the above limitations and or exclusions be detected upon examination.

Keep the information on this page for your records.  
*Please mail-in warranty form on next page*

|                         |       |                       |
|-------------------------|-------|-----------------------|
| <b>PLUSH MODEL</b>      | _____ | <b>PURE GAIN PLUS</b> |
| <b>SERIAL NUMBER</b>    | _____ |                       |
| <b>OPTIONS INCLUDED</b> | _____ |                       |
|                         | _____ |                       |
|                         | _____ |                       |
|                         | _____ |                       |

|                        |                               |
|------------------------|-------------------------------|
| <b>PRODUCTION DATE</b> | ____/____/____                |
| <b>TESTED BY</b>       | _____ Fuchs Audio Technology® |

(973)-772-4420      Plush Division of Fuchs Audio Technology ®  
407 Getty Ave Clifton, NJ 07015  
[www.plush-pedals.com](http://www.plush-pedals.com)      [info@fuchsaudiotechnology.com](mailto:info@fuchsaudiotechnology.com)



®

### WARRANTY REGISTRATION FORM

**This completed form must be returned to Fuchs Audio Technology within 30 days of purchase along with a copy of your receipt from your authorized dealer.**

Please fill in all requested information on this form so we may register you for future warranty repairs or future upgrades, should they become available.

Purchasers Name \_\_\_\_\_

Address \_\_\_\_\_

City \_\_\_\_\_ State \_\_\_\_\_ Zip \_\_\_\_\_ Country \_\_\_\_\_

Phone Number \_\_\_\_\_

E-Mail address \_\_\_\_\_

Model \_\_\_\_\_

Serial Number \_\_\_\_\_

Date of Purchase \_\_\_\_\_

Dealer Name \_\_\_\_\_

Comments:

\_\_\_\_\_  
\_\_\_\_\_  
\_\_\_\_\_  
\_\_\_\_\_  
\_\_\_\_\_

Please return this form to:

Plush Division of Fuchs Audio Technology®

407 Getty Ave Clifton, NJ 07015

(973)-772-4420

[www.fuchsaudiotechnology.com](http://www.fuchsaudiotechnology.com)

[info@fuchsaudiotechnology.com](mailto:info@fuchsaudiotechnology.com)