



User's Manual

event line array

EVENT-26A / EVENT-115A



Antes de utilizar el equipo, lea la sección "Precauciones de seguridad" de este manual. Conserve este manual para futuras consultas.

Before operating the device, please read the "Safety precautions" section of this manual. Retain this manual for future reference.

CONTENTS

SAFETY PRECAUTIONS	3
WARRANTY	4
DECLARATION OF CONFORMITY	5
INTRODUCTION	6 - 7
CONFIGURATIONS	8 - 12
2 x EVENT-26A + 2 x EVENT-115A	
8 x EVENT-26A + 4 x EVENT-115A (flown subs)	
8 x EVENT-26A + 4 x EVENT-115A	
12 x EVENT-26A + 4 x EVENT-115A + 2 x EVENT-121A	
12 x EVENT-26A + 4 x EVENT-218A	
SPECIFICATIONS	13
LINE DRAWINGS	14
AMPLIFIERS	15 - 21
<u>Descriptions</u>	
<u>ON / OFF</u>	
<u>Overload indicator</u>	
<u>Equalisation</u>	
<u>Overheating</u>	
<u>Low mains voltage</u>	
<u>Current consumption</u>	
<u>Troubleshooting</u>	
RIGGING SYSTEM	22 - 31
<u>4 or 6 units mounting on a PL-EV26S flatbed dolly</u>	
<u>Array mounting of groups of 4 units on a flatbed dolly</u>	
<u>EVENT-115A array mounting</u>	
<u>EVENT-26A array mounting "one by one"</u>	
<u>EVENT-115A + EVENT-26A array mounting</u>	
<u>Stacking EVENT-26A on EVENT-115A</u>	
<u>Transporting</u>	
ANNEX : Line connections: unbalanced and balanced	32

Cajas acústicas activas / Self-powered loudspeaker enclosures

El signo de exclamación dentro de un triángulo indica la existencia de importantes instrucciones de operación y mantenimiento en la documentación que acompaña al producto. Conserve y lea todas estas instrucciones. Siga las advertencias. **ATENCIÓN:** Es un producto clase A, por lo que en entornos domésticos puede causar radio-interferencias, en cuyo caso el usuario tendrá que tomar las medidas oportunas. De acuerdo con EN55103-2, usar el equipo sólo en entornos E1, E2, E3 ó E4.



The exclamation point inside an equilateral triangle is intended to alert the users to the presence of important operating and maintenance (servicing) instructions in the literature accompanying the product. Heed all warnings. Follow all instructions. Keep these instructions.

WARNING: This is a class A product. In a domestic environment this product may cause radio interferences in which case the user may be required to take adequate measures. Use this product only in E1, E2, E3 or E4 environments according to EN55103-2.

No desconecte la tierra en el conector de alimentación pues es peligroso e ilegal. Equipo de Clase I. El producto debe ser conectado a un enchufe con toma de tierra. Sólo use este equipo con el cable de red de alimentación adecuado para su país.

El signo del rayo con la punta de flecha, alerta contra la presencia de voltajes peligrosos no aislados. Para reducir el riesgo de choque eléctrico, no retire la cubierta.



Do not remove mains connector ground, it is dangerous and illegal. Class I device. The product must be connected to a mains socket outlet with protective earth connection. Only use this equipment with an appropriate mains cord for your country.

The lightning and arrowhead symbol warns about the presence of uninsulated dangerous voltage. To reduce the risk of electric shock, do not remove the cover.

No instale el aparato cerca de ninguna fuente de calor como radiadores, estufas u otros aparatos que produzcan calor. Debe instalarse siempre sin bloquear la libre circulación de aire por las aletas del radiador.

Do not install near any heat sources such as radiators, heat registers, stoves or other apparatus that produce heat. The circulation of air through the heatsink must not be blocked.

No exponga este equipo a la lluvia o humedad. No use este aparato cerca del agua (piscinas y fuentes, por ejemplo). No exponga el equipo a salpicaduras ni coloque sobre él objetos que contengan líquidos, tales como vasos y botellas. Equipo IP-43.

Do not expose this device to rain or moisture. Do not use this apparatus near water (for example, swimming pools and fountains). Do not place any objects containing liquids, such as bottles or glasses, on the top of the unit. Do not splash liquids on the unit. IP-43 equipment.

Este símbolo indica que el presente producto no puede ser tratado como residuo doméstico normal, sino que debe entregarse en el correspondiente punto de recogida de equipos eléctricos y electrónicos.



This symbol on the product indicates that this product should not be treated as household waste. Instead it shall be handed over to the applicable collection point for the recycling of electrical and electronic equipment.

Equipo diseñado para funcionar entre 15°C y 45°C con una humedad relativa máxima del 95%, con un rango de $\pm 10\%$ de la tensión nominal de alimentación indicada en la etiqueta trasera. Si debe sustituir el fusible preste atención al tipo y rango.

Working temperature ranges from 15°C to 45°C with a relative humidity of 95%, with $\pm 10\%$ of the rated main voltage value indicated on the rear label. If the fuse needs to be replaced, please pay attention to correct type and ratings.

El cableado exterior conectado al equipo requiere de su instalación por una persona instruida o el uso de cables flexibles ya preparados.

The outer wiring connected to the device requires installation by an instructed person or the use of a flexible cable already prepared.

Si el aparato es conectado permanentemente, la instalación eléctrica del edificio debe incorporar un interruptor multipolar con separación de contacto de al menos 3mm en cada polo.

If the apparatus is connected permanently, the electrical system of the building must incorporate a multipolar switch with a separation of contact of at least 3mm in each pole.

Para desconectar el dispositivo debe usar el enchufe. Desconecte este aparato durante tormentas eléctricas, terremotos o cuando no se vaya a emplear durante largos periodos.

To disconnect the device, you should use the mains plug. Unplug this apparatus during lightning storms, earthquakes or when unused for long periods of time.

No emplace altavoces en proximidad a equipos sensibles a campos magnéticos, tales como monitores de televisión o material magnético de almacenamiento de datos.



Do not place loudspeakers in proximity to devices sensitive to magnetic fields such as television monitors or data storage magnetic material.

Para **EVENT-26A**, la altura máxima de seguridad desde el suelo a la base de la caja montada sobre trípode modelo **TRD-2** (necesita además **AXS-EV26**), con pies a 55 cm del eje del trípode, es:

For **EVENT-26A**, the maximum safety height from floor to bottom of enclosure when mounting on a **TRD-2** tripod (it needs also **AXS-EV26**), with legs spread 55cm from the central pole, is:

1x **EVENT-26A** ----->142 cm
2x **EVENT-26A** ----->132 cm

1x **EVENT-26A** ----->142 cm
2x **EVENT-26A** ----->132 cm

El colgado del equipo sólo debe realizarse utilizando los herrajes de colgado recomendados y por personal cualificado. No cuelgue la caja de las asas.

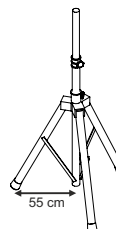

The appliance should be flown only from the rigging points and by qualified personnel. Do not suspend the box from the handles.

No existen partes ajustables por el usuario en el interior de este equipo. Cualquier operación de mantenimiento o reparación debe ser realizada por personal cualificado. Es necesario el servicio técnico cuando el equipo se haya dañado de alguna forma, como que haya caído líquido o algún objeto en el interior del aparato, haya sido expuesto a lluvia o humedad, no funcione correctamente, haya recibido un golpe o su cable de red esté dañado.

No user serviceable parts inside. Refer all servicing to qualified service personnel. Servicing is required when the apparatus has been damaged in any way, such as power-supply cord or plug is damaged, liquid has been spilled or objects have fallen into the apparatus, the apparatus has been exposed to rain or moisture, does not operate normally or has been dropped.

Limpie con un paño seco. No use limpiadores con disolventes.

Clean only with a dry cloth. Do not use any solvent based cleaners.

GARANTÍA

Todos nuestros productos están garantizados por un periodo de 24 meses desde la fecha de compra.

Las garantías sólo serán válidas si son por un defecto de fabricación y en ningún caso por un uso incorrecto del producto.

Las reparaciones en garantía pueden ser realizadas, exclusivamente, por el fabricante o el servicio de asistencia técnica autorizado.

Para solicitar reparación en garantía es imprescindible que el producto no haya sido previamente manipulado e incluir una fotocopia de la factura de compra.

Todos los detalles relativos a la garantía (como las garantías extendidas) los puede encontrar en la sección SOPORTE en nuestra web: www.dasaudio.com

WARRANTY

All our products are warrantied against any manufacturing defect for a period of 24 months from date of purchase.

The warranty excludes damage from incorrect use of the product.

All warranty repairs must be exclusively undertaken by the factory or any of its authorised service centers.

To claim a warranty repair, do not open or intend to repair the product.

All the details related to the warranty (such as extended warranties) can be found in the SUPPORT section on our website: www.dasaudio.com



DECLARACIÓN DE CONFORMIDAD DECLARATION OF CONFORMITY

DAS Audio Group, S.L.

C/ Islas Baleares, 24 - 46988 - Pol. Fuente del Jarro - Valencia. España
(Spain).

Declara que los modelos EVENT-26A y EVENT-115A:
Declares that models EVENT-26A and EVENT-115A:

Cumple con los objetivos esenciales de las Directivas:
Abide by essential objectives relating Directives:

- | | |
|--|------------|
| ● Directiva de Baja Tensión (Low Voltage Directive) | 2014/35/UE |
| ● Directiva de Compatibilidad Electromagnética (EMC) | 2014/30/UE |
| ● Directiva RoHS | 2011/65/UE |
| ● Directiva RAEE (WEEE) | 2012/19/UE |

Y es conforme a las siguientes Normas Armonizadas Europeas:
In accordance with Harmonized European Norms:

- EN 60065:2014.- Audio, video and similar electronic apparatus. Safety requirements.
- EN 55032:2012.- Electromagnetic compatibility of multimedia equipment. Emission requirements.
- EN 55103-2:2009.- Electromagnetic compatibility. Product family standard for audio, video, audio-visual and entertainment lighting control apparatus for professional use. Part 2:Immunity.
- EN 50581:2012.- Technical documentation for the assessment of electrical and electronic products with respect to the restriction of hazardous substances.

INTRODUCTION

For portable live sound applications, or fixed installations in almost any type of small-mid sized venue, the EVENT-26A Line Array has been designed to provide exceptional sound and coverage, steadfast reliability and value beyond comparison.

The EVENT-26A Array incorporates a high frequency waveguide and horn assembly designed with the same technology, tools and knowledge as the aero series.

Features

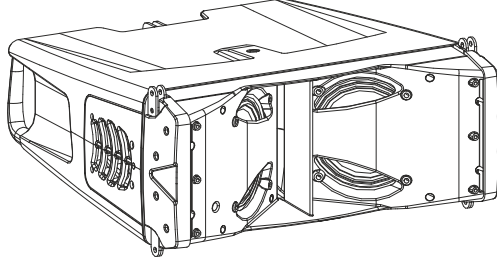

EVENT-26A

EVENT-26A

- Ultra-compact, lightweight powered line array
- High-efficiency Class D amplifier with SMPS Dual voltage mains for use anywhere in the world
- 100° wide coverage
- 2 x 6.5", 6Mi, loudspeakers in a symmetric V-shape configuration
- Easy system configuration thanks to DAScontrol™
- High-end 24-bit DSP with LCD screen FIR processing technology for constant phase response FSSTM Fast Set Splay rigging for quick deployment

The EVENT-26A is a symmetrical, ultra-compact, two-way powered line array system. Designed by DAS engineers to deliver stunning performance and exceptional ease-of-use, the stylish polypropylene cabinet design offers a highly portable and road-worthy system. A comprehensive range of accessories makes the EVENT-26A ideal for small to mid-size rental and installation applications.

The EVENT-26A combines two 6.5" transducers and a single M-60 compression driver in a rugged yet lightweight polymer cabinet. The symmetric "V" shaped configuration of the cone transducers provides consistent 100° of horizontal coverage down to 200 Hz. The M-60 compression driver is coupled to an advanced waveguide design that provides control of the vertical dispersion as well as precise coupling between units when used in vertical arrays.

Powered by a two-channel Class D amplifier providing 800 W_{peak} power, the amp's rear panel includes quality Neutrik® XLR and powerCON connectors. The DAScontrol™ interface makes the preset selection for the number of units in the array both fast and simple. An onboard DSP featuring a 24-bit high-end processor handles X-over, EQ, delay, and limiter functions. The powerful FIR filtering technology incorporated in the EVENT-26A offers constant phase response which translates to transparent sound and exceptional clarity, improving the listening experience.

Streamlined deployment of EVENT-26A arrays is possible thanks to the innovative FSSTM (Fast Set Splay) rigging system developed to permit angle selection while stacked on dollies. The stainless steel rigging hardware allows flown arrays of up to 16 units in 1° steps from 0° to 10°.

Low-frequency reinforcement for the EVENT-26A is provided by its flyable companion subwoofer the EVENT-115A.

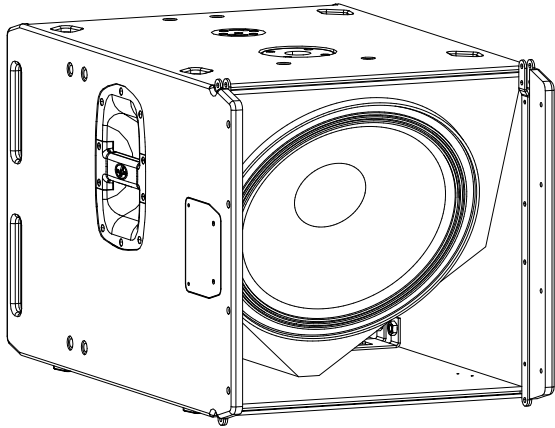

EVENT-115A

EVENT-115A

- Active front-loaded subwoofer system
- 1 x 15" DAS 15FW4 loudspeaker
- High-efficiency Class D amplifier with SMPS Dual voltage mains for use anywhere in the world
- Easy system configuration thanks to DAScontrol™ High-end 24-bit DSP with LCD screen
- EVENT-115A compatible rigging hardware

The EVENT-115A is a compact powered subwoofer system which uses a front-loaded 15" low frequency transducer developed by DAS. Designed as the companion subwoofer for the EVENT-26A, they share a compatible rigging system which allows the EVENT-26A to be flown from or stacked above the EVENT-115A.

The 15FW4 15" loudspeaker used in the EVENT-115A has been engineered by DAS to provide outstanding performance and reliability. The 15FW4 speaker design has been optimized using Finite Element Analysis (FEA) and incorporates an extended 3" voice coil for high-efficiency and long excursion offering a power handling capacity of 1200 W_{program}. Efficient cooling is assured thanks to the 15FW4's vented pole piece and abundant apertures in the speaker's back plate keeping power compression to a minimum while providing high acoustic output over extended periods.

Driving the DAS 15FW4 loudspeaker is a cutting-edge 1200 W_{peak} Class D amplifier. On the rear panel, quality Neutrik XLR input connectors and stereo "loop thru" output connections are available to provide signal for the EVENT-26A systems. Thanks to the digital presets accessible by way of the DAScontrol™ interface on the rear of the cabinet, set-up of a complete systems is extremely easy.

The EVENT-115A cabinet is constructed from Birch plywood using a robust enclosure design and finished with the DAS ISO-flex protective coating for extended durability. The rigging hardware is compatible with the EVENT-26A allowing it to be flown directly below or stacked above the subwoofer unit. A top located pole mount socket is available allowing the EVENT-26A to be used in a combo configuration.

CONFIGURATIONS

2 x EVENT-26A + 2 x EVENT-115A

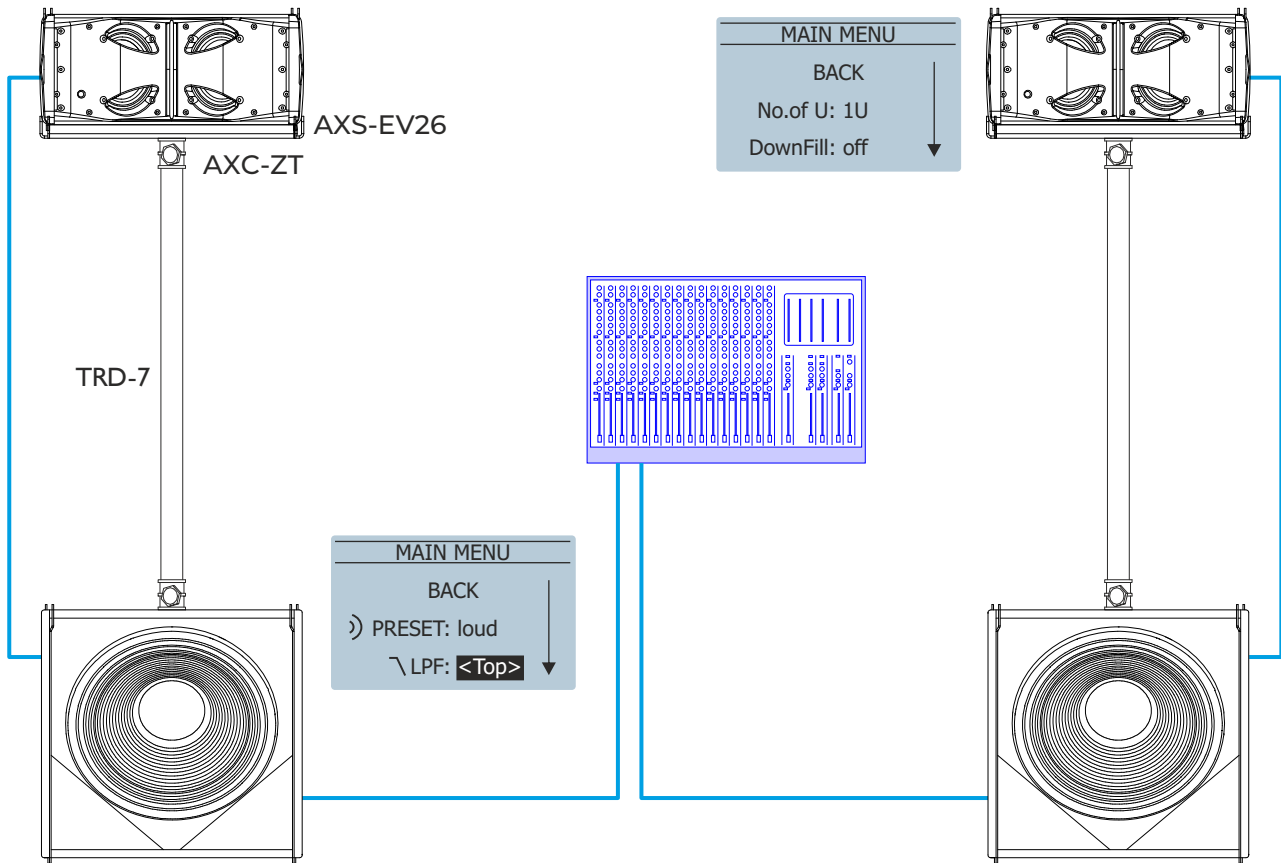

Processors

Units

Speaker cabling

SC2 2m XLR microphone signal balanced cable	2
SC20 20m XLR microphone signal balanced cable	2

Rigging frames

AXS-EV26 Stacking bumper for EVENT-26A	2
TRD-7 Telescopic pole mount	2
AXC-ZT Speaker adaptor for pole mount	2

Dollies

PL-EV115S Plywood transport dolly for EVENT-115A	1
PL-EV26S Steel transport dolly for EVENT-26A	1

CONFIGURATIONS (cont'd)

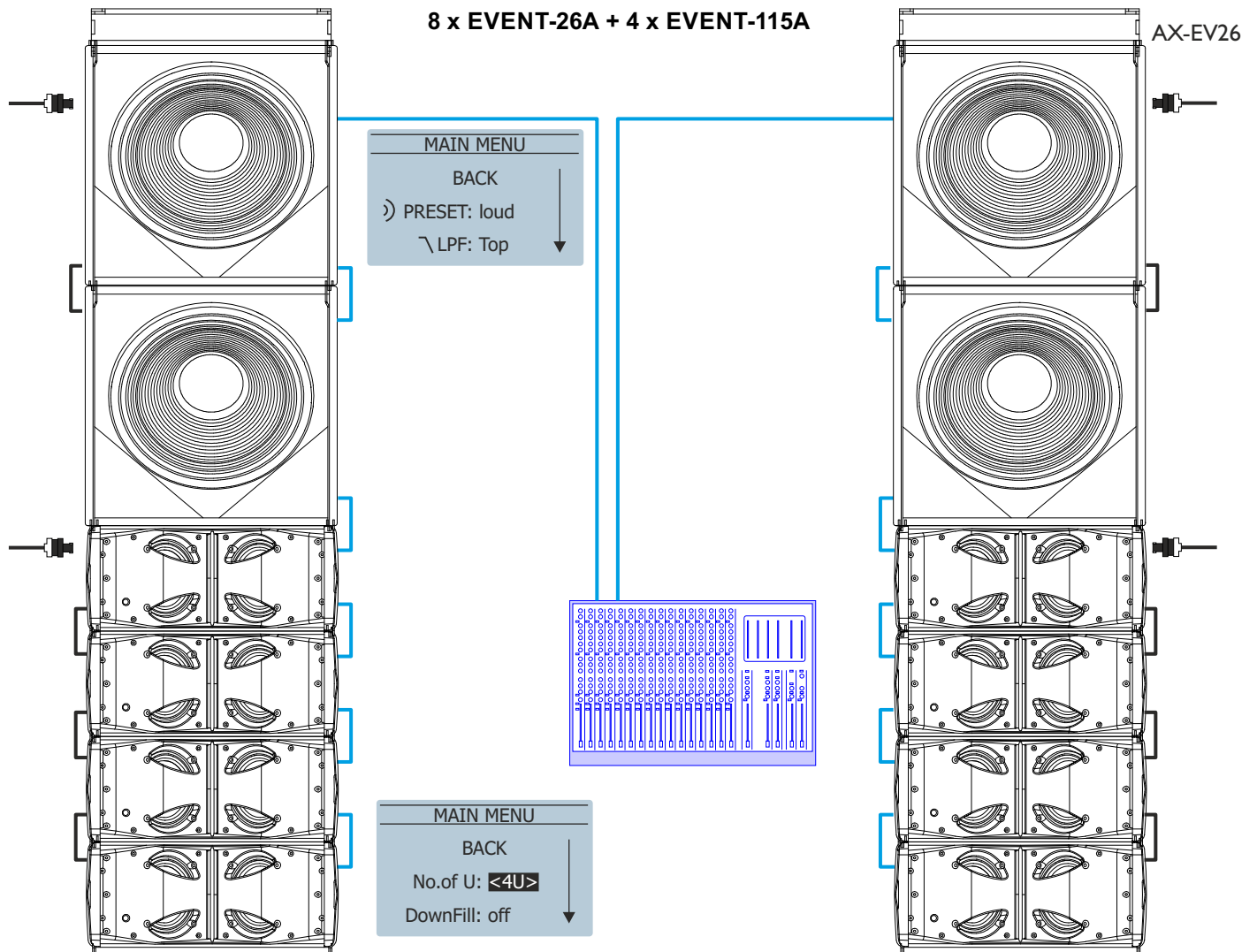

Processors

Units

Speaker cabling

SC-1 1m XLR microphone signal balanced cable	4
SC-20 20m XLR microphone signal balanced cable	2
SC-05 0.5m XLR microphone signal balanced cable	6
PWCONLINK-09 0.9m powerCON "jumper" NAC3FCB cable	8

Rigging frames

AX-EV26 Rigging bumper for EVENT-26A / EVENT-115A	2
JP-EV26 Joining plate for EVENT-26A / EVENT-115A	2

Dollies

PL-EV115S Plywood transport dolly for EVENT-115A	2
PL-EV26S Steel transport dolly for EVENT-26A	2

CONFIGURATIONS (cont'd)

8 x EVENT-26A+ 4 x EVENT-115A

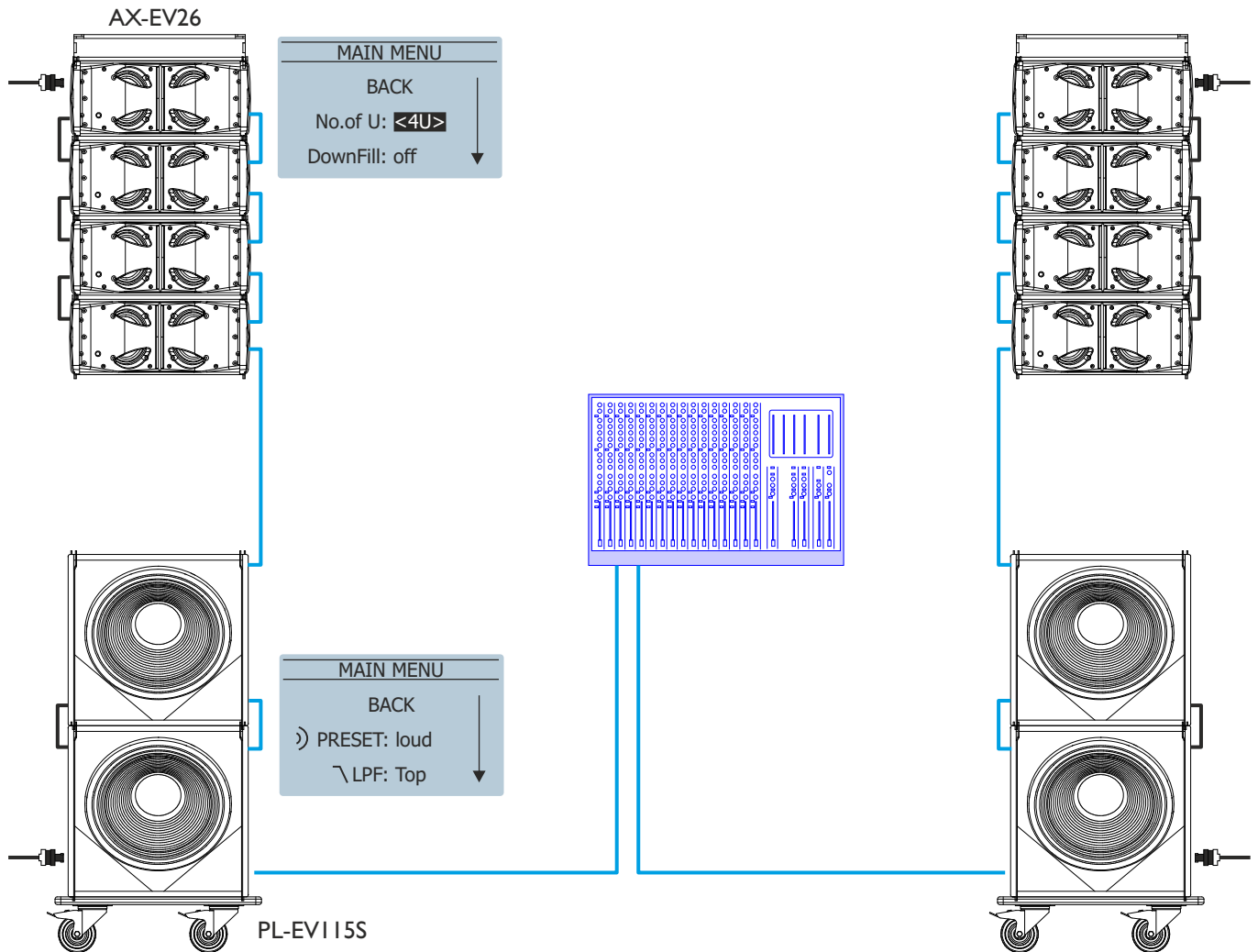

Processors

Units

Speaker cabling

SC-1 1m XLR microphone signal balanced cable	2
SC-5 5m XLR microphone signal balanced cable	2
SC-05 0.5m XLR microphone signal balanced cable	6
SC-20 20m XLR microphone signal balanced cable	2
PWCONLINK-09 0.9m powerCON "jumper" NAC3FCB cable	8

Rigging frames

AX-EV26 Rigging bumper for EVENT-26A / EVENT-115A	2
--	---

Dollies

PL-EV115S Plywood transport dolly for EVENT-115A	2
PL-EV26S Steel transport dolly for EVENT-26A	2

CONFIGURATIONS (cont'd)

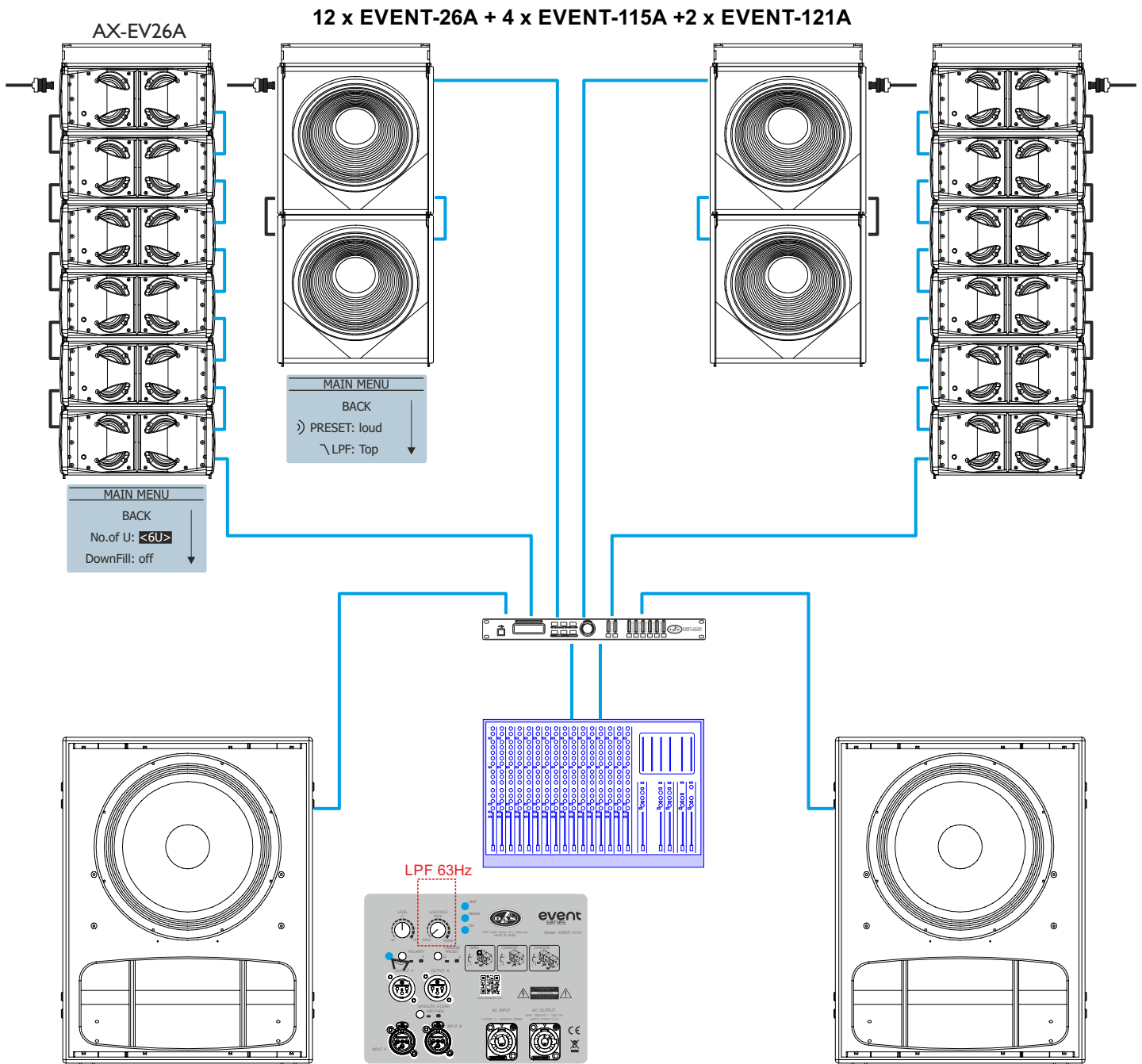

Processors

DSP-226 2 IN x 6 OUT digital signal processor

Units

1

Speaker cabling

SC-1 1m XLR microphone signal balanced cable

2

SC-05 0.5m XLR microphone signal balanced cable

10

SC-20 20m XLR microphone signal balanced cable

2

PWCONLINK-09 0.9m powerCON "jumper" NAC3FCB cable

12

Rigging frames

AX-EV26 Rigging bumper for EVENT-26A / EVENT-115A

2

Dollies

PL-EV115S Plywood transport dolly for EVENT-115A

2

PL-EV26S Steel transport dolly for EVENT-26A

2

12 x EVENT-26A+4 x EVENT-218A

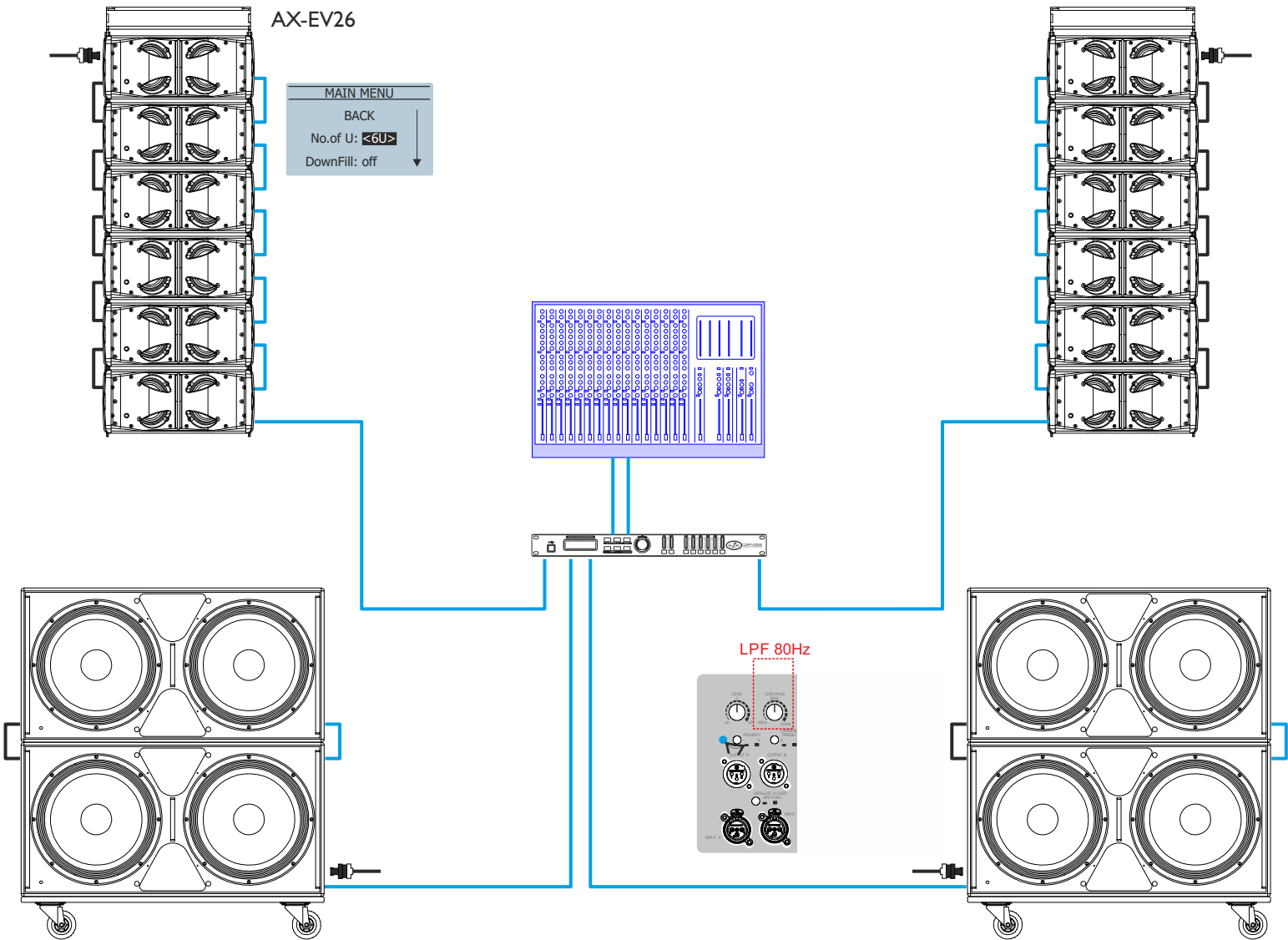

Processors	Units
DSP-226 2 IN x 6 OUT Digital Signal Processor	1
Speaker cabling	
SC-05 0.5m XLR microphone signal balanced cable	10
SC-1 1m XLR microphone signal balanced cable	2
SC-20 20m XLR microphone signal balanced cable	4
PWCONLINK-09 0.9m powerCON "jumper" NAC3FCB cable	12
Rigging frames	
AX-EV26 Rigging bumper for EVENT-26A / EVENT-115A	2
Dollies	
PL-EV218S Plywood transport dolly for EVENT-218A	2
PL-EV26S Steel transport dolly for EVENT-26A	2

SPECIFICATIONS

Model	EVENT-26A	EVENT-115A
Nominal LF Power Amplifier	600W _{peak} - 300 W _{continuous}	1200W _{peak} - 600 W _{continuous}
Nominal HF Power Amplifier	200W _{peak} - 100 W _{continuous}	---
Input Type	Balanced Differential Line	Balanced Differential Line
Input Impedance	Line: 20 kohms	Line: 20 kohms
Sensitivity	Line: 6.2 V (+18 dBu)	Line: 6.2 V (+18 dBu)
Frequency Range (-10 dB)	80 Hz -17 kHz	40 Hz -125 Hz
Horizontal Coverage (-6dB)	100° Nominal	---
Vertical Coverage	Splay Dependent	Splay Dependent
Rated Maximum Peak SPL at 1 m ⁽¹⁾	131dB	131 dB
Transducers/Replacement Parts	LF: 2 x 6MI/ 6MI HF: 1 x M-60/GM-M60N	LF: 1 x 15FW4/GM-15FW4
Enclosure Geometry	Trapezoidal 5°	Rectangular
Enclosure Material	ABS High Impact	Birch Plywood
Color/Finish	Black Polyurea Paint	Black Polyurea Paint
Rigging System Splay Angles	Integrated in box design	Integrated in box design
Connectors	INPUT: 1 x Female XLR LOOP THRU: 1 x Male XLR AC INPUT: 1 x powerCON NAC3FCA AC OUTPUT: 1 x powerCON NAC3FCB	INPUT: 2 x Female XLR LOOP THRU: 2 x Male XLR AC INPUT: 1 x powerCON NAC3FCA AC OUTPUT: 1 x powerCON NAC3FCB
AC Power Requirements	115 V, 3.6A, 50 Hz/60 Hz 230 V, 1.8A, 50 Hz/60 Hz	115 V, 3.6A, 50 Hz/60 Hz 230 V, 1.8A, 50 Hz/60 Hz
Dimensions (H x W x D)	225 x 480 x 485 mm 8.9 x 18.9 x 19.1 in	481 x 485 x 770 mm 18.9 x 18.9 x 19.1 in
Weight	16.5 kg (36.3 lb)	36.8 kg (81 lb)
Accessories	AX-EV26 Rigging System AXS-EV26 Stacking Base FUN-4-EV26 Transport Cover FUN-6-EV26 Transport Cover PL-EV26S Stacking Dolly JP-EV26 Joining plate AXC-ZT TRD-2 Tripod TRD-7 Extensible Pole Mount	AX-EV26 Rigging System FUN-2-EV115 Transport Cover PL-EV115S Stacking Dolly JP-EV26 Joining plate TRD-7 Extensible Pole Mount

(1). Maximum calculated Peak SPL based on sensitivity and RMS power handling.

DAS Audio Group, S.L. continuously strives to enhance its products through investigation and development. All specifications are subject to change without prior notice.

LINE DRAWINGS

EVENT-26A

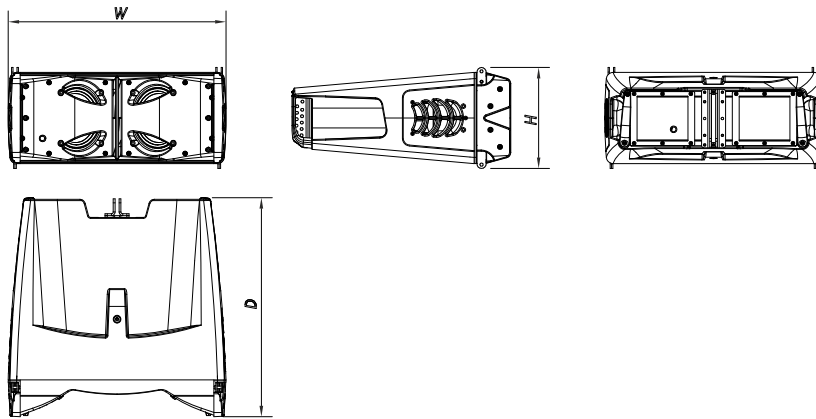

EVENT-115A

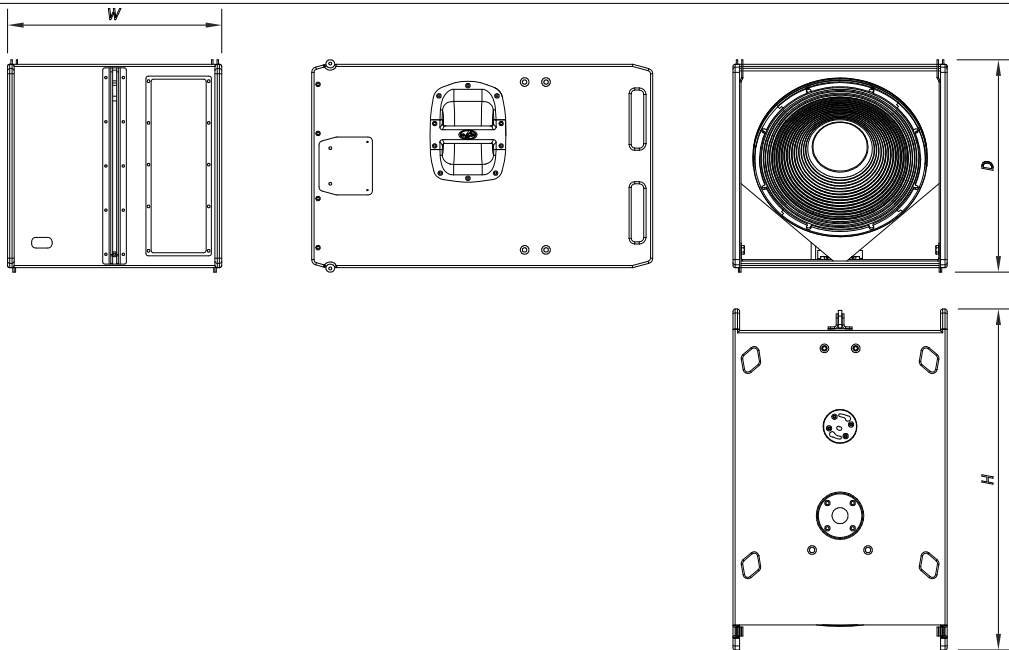

AMPLIFIERS

EVENT-26A amplifier

1) INPUT :

XLR socket-type input signal connector. This is a balanced connector just like the OUTPUT connector with the following pin assignments:

1 or S =GND (ground) 2 or T =(+) Non inverted input 3 or R =(-) Inverted input

2) OUTPUT :

XLR-type output signal connectors for connecting several units together and sending them all the same input signal (THRU).

3) DISPLAY:

LIMIT /INPUT CLIP :

The signal's input level can be monitored in the LCD screen on the left meter. When the signal level is too high the Display will show "INPUT CLIP". Please reduce the level accordingly.

The output level with respect to the Limiter threshold can be monitored on the right meter. When the value reaches the limiter threshold the Display will show "LIMIT" (depending on the configuration mode the Display can be programmed to blink when the system is limiting).

SIGNAL :

The left meter indicates the presence of signal.

ON :

The Display will be illuminated when the system is on.

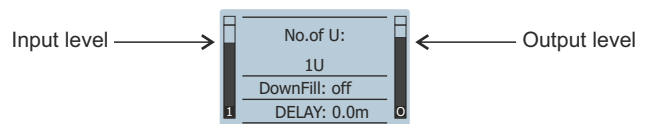

The background light of the display can be switched off permanently by selecting in the options / Dimming menu, the "dark" preset. This option will make the Display blink (on and off) when the system reaches its limit. This option maybe useful in theaters or similar applications in order to reduce the visual contamination.

4) ENCODER (DAScontrol) :

Use the rotary encoder to navigate for preset selection (number of units, downfill) and options (reset, dimming etc).

5) AC INPUT :

PowerCon NAC3FCA mains connector (inserted, rotated and locked for ON). Only use this equipment with an appropriate mains cord.

6) AC OUTPUT :

PowerCon NAC3FCB connector for AC loop thru (see unit's label)). Only use this equipment with an appropriate mains cord.

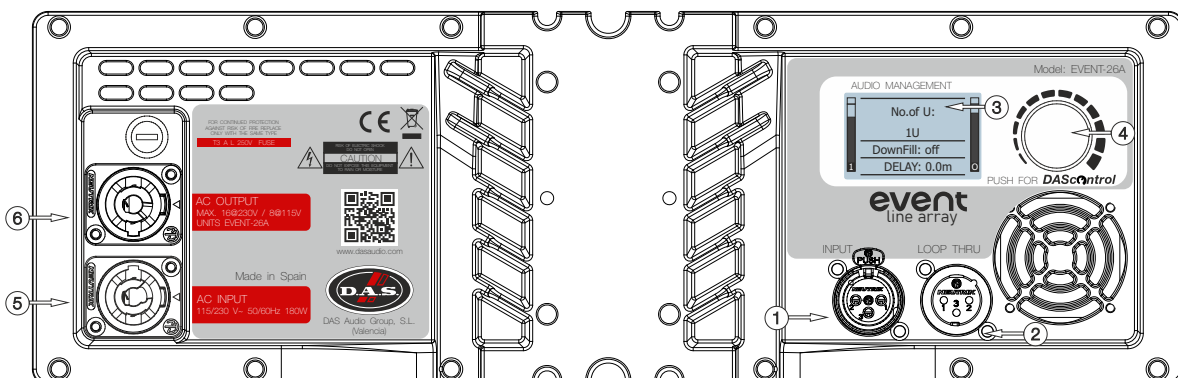

EVENT-115A amplifier

1) INPUT :

1/4" Jack+XLR combined socket-type input signal connector. This is a balanced connector just like the OUTPUT connector with the following pin assignments:

1 or S =GND (ground) 2 or T =(+) Non inverted input 3 or R =(-) Inverted input

2) OUTPUT :

A and B, XLR-type output signal connectors for connecting several units together and sending them all the same input signal (THRU).

3) DISPLAY:

LIMIT /INPUT CLIP :

The signal's input level can be monitored in the LCD screen on the left meters, channels 1 and 2. When the signal level is too high the Display will show "INPUT CLIP". Please reduce the level accordingly.

The output level with respect to the Limiter threshold can be monitored on the right meter. When the value reaches the limiter threshold the Display will show "LIMIT" (depending on the configuration mode the Display can be programmed to blink when the system is limiting).

SIGNAL :

The left meter indicates the presence of signal.

ON :

The Display will be illuminated when the system is on.

The background light of the display can be switched off permanently by selecting in the options / Dimming menu, the "dark" preset. This option will make the Display blink (on and off) when the system reaches its limit. This option maybe useful in theaters or similar applications in order to reduce the visual contamination.

4) ENCODER (DAScontrol) :

Use the rotary encoder to navigate for preset selection (Low Pass Filter, deep-loud etc) and options (reset, dimming etc).

5) AC INPUT :

PowerCon NAC3FCA mains connector (inserted, rotated and locked for ON). Only use this equipment with an appropriate mains cord.

6) AC OUTPUT :

PowerCon NAC3FCB connector for AC loop thru (see unit's label)). Only use this equipment with an appropriate mains cord.

7) POWER :

'Mains power ON/OFF switch. To disconnect the device the user should use the mains plug.

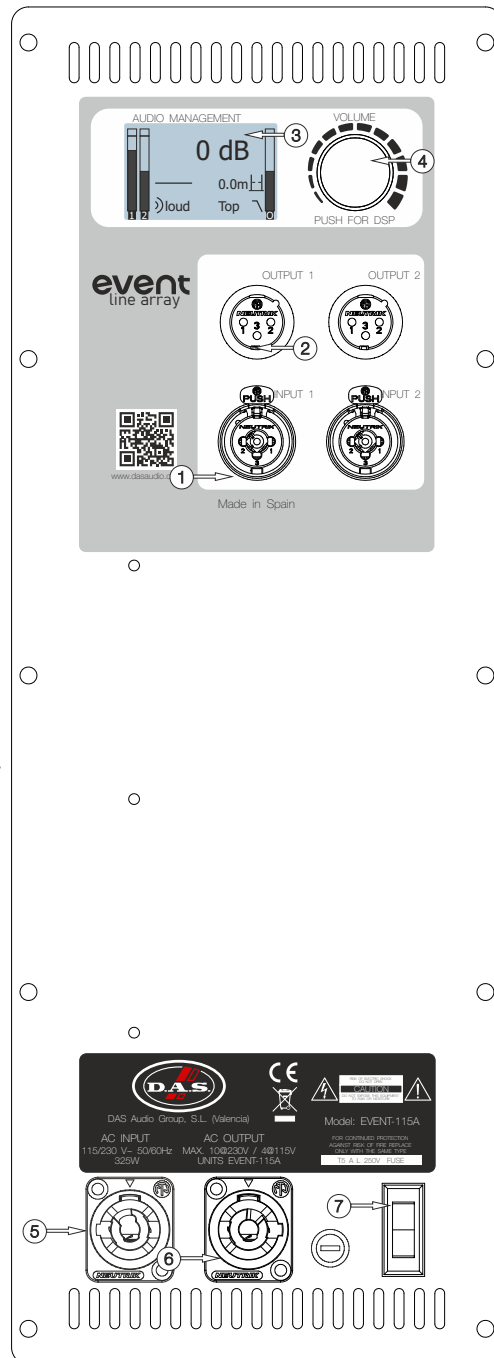

DAScontrol and display navigation

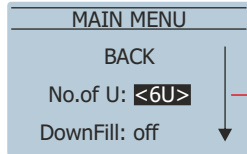
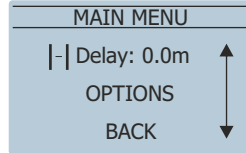
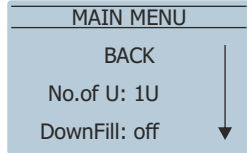
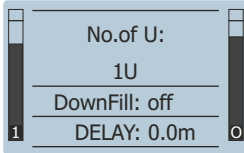

1U
2U
4U
6U
8U
12U

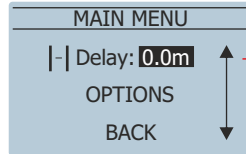

0.0m
9.9m

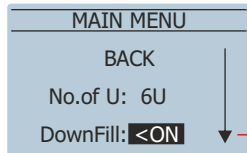

ON
off

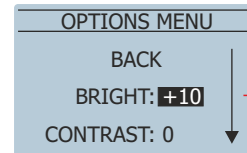
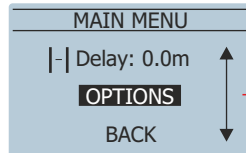

+10
-10

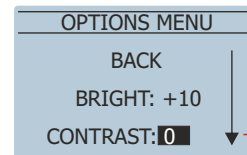

+10
-10

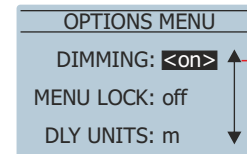

off
on
dark

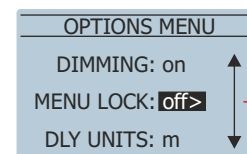

off
on
pw292

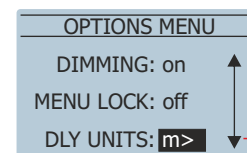

m
ft

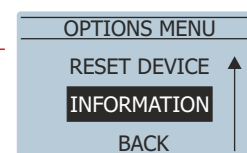
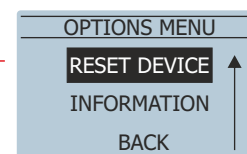
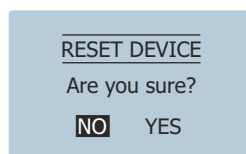

off: the background light is always on.
on: the background light is lowered when the system doesn't Limit. when Limit is reached the background light increases its luminosity.
dark: the background light is always off.

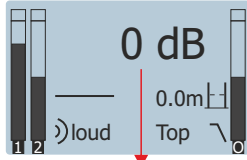

Level control: can be adjusted between MUTE (-60dB) and 0dB

Top: recommended when using the subwoofer with EVENT-26A

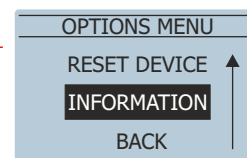
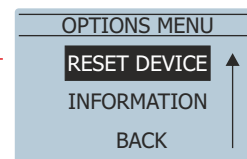
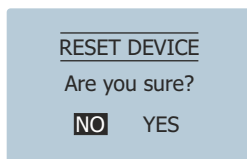
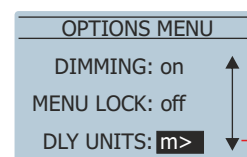
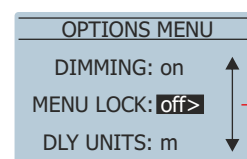
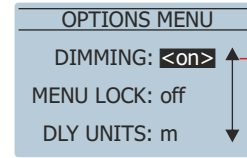
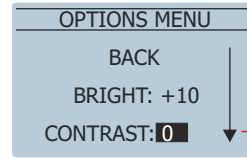
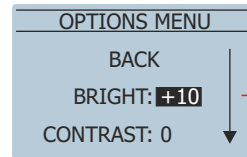
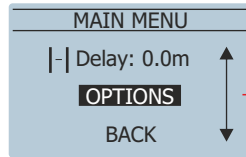
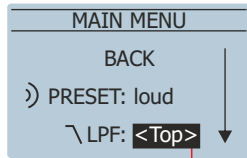
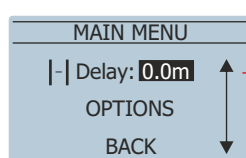
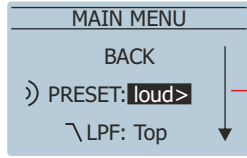
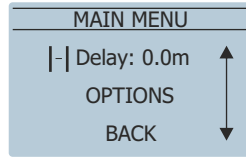
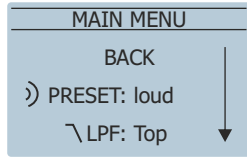

off: the background light is always on.
 on: the background light is lowered when the system doesn't Limit. when Limit is reached the background light increases its luminosity.
 dark: the background light is always off.

RECOMMENDATIONS OF USE

ON/OFF

A sound system should be switched on sequentially. Switch on the self-powered units last in your sound system (switch on the subwoofer before the mid-high system). Switch on the sound sources such as CD players or turntables, then the mixer, then the processors, and finally the self-powered unit. If you have several units, it is recommended that you switch them on sequentially one at a time.

Follow the inverse order when switching off, turning self-powered units off before any other element in the sound system.

Disconnect the device by removing the mains connector from the mains socket. The mains connector and mains socket must always be freely accessible and never covered or blocked in any way.

The models use a power cable equipped with a Neutrik PowerCon NC3FCA connector. Power can be daisy chained via the NC3FCB output connector (see details on product label).

IMPORTANT: Do not disconnect the unit while in use.

Ensure that the device is disconnected from the mains by observing that the display is turned off.

Overload indicator (LIMIT / INPUT CLIP)

This device has an indicator (LIMIT / INPUT CLIP) that it is shown on the display when the signal level is excessive.

The indicator should not be lit continuously. This distorts the signal (quickly fatiguing your ears) and may damage the speakers. Therefore, it is recommended that you never work with these two messages engaged; at most it should blink only occasionally.

Equalisation

It is recommended the use of a computer based dual-channel FFT platform to view the frequency content of signals or measure the response of the entire electro-acoustic system, all to better make informed decisions about the deployment and operation of these systems.

The unit does not need extreme settings of equalisation to produce quality sound, just select the parameter "number of units" in the amplifier that corresponds to the amount of systems used and you will achieve a very good and balanced starting point before measuring and tuning the system.

Avoid high levels of gain on the equalisers. Gain values above +6 dB on a console's / processor's EQ are not recommended.

Overheating

This equipment does not normally overheat during normal conditions of use. When overheating occurs, the FAN (EVENT-26A) will automatically start working reducing the temperature of the unit. Make sure that the rain protectors are properly separated from the amplifier's back plate in order to not block the air flux thru the fan.

Air circulates from the bottom to the top of the amplifier.

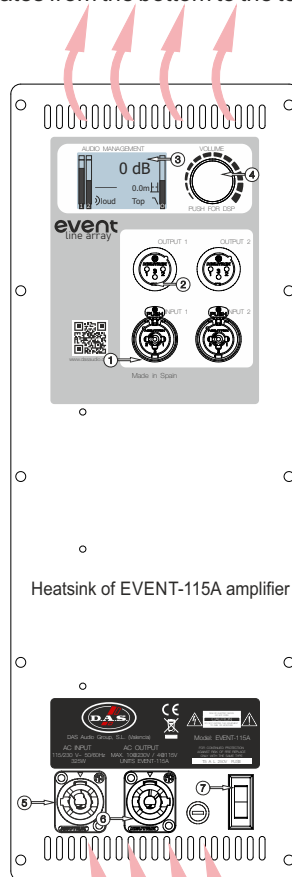

Heatsink of EVENT-115A amplifier

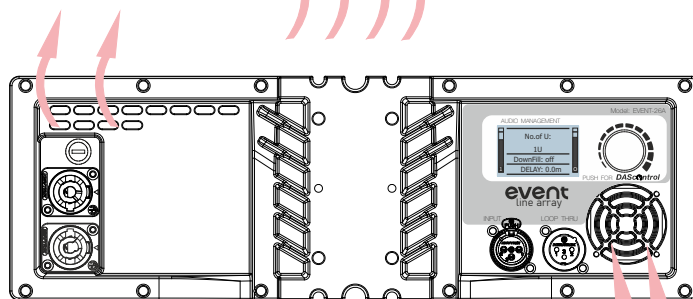

Heatsink of EVENT-26A amplifier

Low mains voltage

If mains voltage falls below the shutdown voltage for the unit, it will stop playing, typically this value would be below 90Volts. When acceptable levels are regained, the unit will switch back on automatically.

Therefore the current consumed by a 115V version is double the 230V version to achieve the same acoustic power level.

<i>Pink Noise Mains 230 Vrms</i>	1/3 Power
EVENT-26A	0.8A
EVENT-115A	1.4A

Troubleshooting

PROBLEM	CAUSE	SOLUTION
No sound from the unit. The DISPLAY does not light up.	<ol style="list-style-type: none"> 1 - No power to the unit. 2 - Defective cable / connector. 3 - Defective amplifier. 	<ol style="list-style-type: none"> 1 - Check all the connections and the power distro. 2 - Check that the cable and connector are working properly. 3 - Contact with the dealer/tech support in the area.
Full power cannot be obtained. The LIMIT message is never displayed.	<ol style="list-style-type: none"> 1 - The signal source does not have a hot enough output. 2 - There could be some equalisations, filters or compressors applied in other devices (console, processor). 	<ol style="list-style-type: none"> 1 - If you use a mixer, be sure to use the balanced output if you have it. Use a professional mixer or signal source with more output level. 2 - Double check the signal path and erase all Eqs, compressors applied.
Sound is distorted. The LIMIT message is not on, or only lights up occasionally but INPUT Clip is on.	The mixer or signal source is distorting or it has excessive level.	Turn mixer channel gains down. Check that none of your signal sources are distorting.
Sound is distorted and very loud and LIMIT message is shown.	The system is overloaded and has reached maximum power.	Turn down the mixer's output.
Hum or buzz when a mixer is connected to the unit.	<ol style="list-style-type: none"> 1.- The console probably has un-balanced outputs. You may be using an incorrect un-balanced to balanced cable. 2.- The mixer and the powered speaker are not plugged into the same mains outlet. 3.- The audio signal cable is too long or too close to an AC cable 	<ol style="list-style-type: none"> 1.- Read the appendix of this manual to make a correct un-balanced to balanced cable. 2.- Connect the mixer and the unit to the same mains outlet. 3.- Use a cable that is as short as possible and/or move the audio signal cable away from mains cables.
Hum or buzz when using lighting controls in the same building.	<ol style="list-style-type: none"> 1.- The audio signal cable is too long or too close to the lighting cable. 2.- On a sound system with three-phase AC, the lighting equipment and the UNIT are connected to the same phase. 	<ol style="list-style-type: none"> 1.- Move the audio signal cable away from lighting cables. Try to find out at what point the noise is leaking into the system. 2.- Connect the sound system to a different phase than the lights. You may need the help of an electrician.
The DISPLAY does not light up when the mains connector is connected and the unit is switched to ON.	<ol style="list-style-type: none"> 1.- Bad or loose AC connection to the UNIT or the mains outlet. 2- Faulty AC cable. 3- Blown Fuse. 4 - The mains voltage is out of range. 	<ol style="list-style-type: none"> 1.- Check your connections. 2.- Check the cables, connectors and AC power with a suitable mains tester. 3.- Replace the blown fuse for another of the same type and size. 4.- If the multimeter determines that the mains voltage is out the range, you may need the assistance of an electrician to find an appropriate solution.



Warning

This manual offers all the necessary information for flying or stacking EVENT Line Array series systems of DAS Audio. This information is illustrated with drawings and required safety precautions.

To any operations related to flying a system, read the present document first and act on the warnings and advice given. The goal is to allow the user to become familiar with the mechanical elements required to fly the acoustic system, as well as the safety measures to be taken during set-up and teardown.

Only experienced installers with adequate knowledge of the equipment and local safety regulations should fly speaker boxes. It is the user's responsibility to ensure that the systems to be flown (including flying accessories) comply with state and local regulations.

The working load limits in this manual are the results of tests by independent laboratories. It is the user's responsibility to follow and comply with safety factors, resistance values, periodical supervisions and warnings given in this manual. Product improvement by means of research and development is on going at DAS Audio Group, S.L. Specifications are subject to change without notice.

It is common practice to apply 5:1 safety factors for enclosures and static elements. For slings and elements exposed to material fatigue due to friction and load variation the following ratios must be met; 5:1 for steel cable slings; 4:1 for steel chain slings and 7:1 for polyester slings. Thus, an element with a breaking load limit of 1000 kg may be statically loaded with 200 kg (5:1 safety factor) and dynamically loaded with 142 kg (7:1 safety factor).

When a system is flying, the working load must be lower than the resistance of each individual flying point in the enclosure, as well as each box. Hanging hardware should be regularly inspected and suspect units replaced if in doubt. This is important to avoid injury and absolutely no risks should be taken in this respect. It is highly recommended that you implement an inspection and maintenance program on flying elements, including reports to be filled out by the personnel that will carry out the inspections. Local regulations may exist that, in case of accident, may require you to prevent evidence of inspection reports and corrective actions after defects were found.

Absolutely no risks should be taken with regards to public safety.

When flying enclosures from ceiling support structures, extreme care should be taken to assure the load bearing capabilities of the structures so that the installation is absolutely safe. Do not fly enclosures from unsafe structures. Consult a certified professional if needed. All flying accessories that are not supplied by DAS Audio are the user's responsibility. Use at your own risk.

4 or 6 units mounting on a PL-EV26S flatbed dolly

Groups of four or six units are easy to transport by truck as we will see in this manual.

Once the packaging is removed, you can see four security locking pins on the rear enclosure's rigging system. These pins are going to be used to stack the cabinets; always use the pins of the unit to attach the one that is going to be located above it. The rigging system of the EVENT-26A employs a 3 point attaching system. Use two of the pins in the front left and right structures and the other two in the rear one.



The PL-EV26S includes 3 locking pins to stack the first unit.

Warning: For transport, introduce the pin in hole 1° at "Rear Link" in the first EVENT-26A

The next figure shows the detail of the label located at the rear rigging structure of the EVENT-26A.

Splay angles vary from 0° to 10° in steps of 1°.

To secure (lock the movement) the systems when flying or stacking them, two pins are needed at the rear. One must be introduced in the "splay" angle hole, and the other in the "splay+1°" hole.

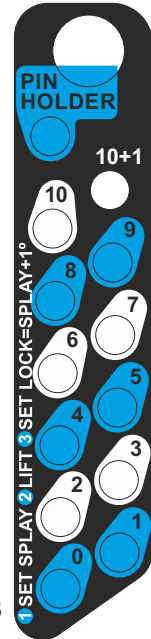

Fig.3

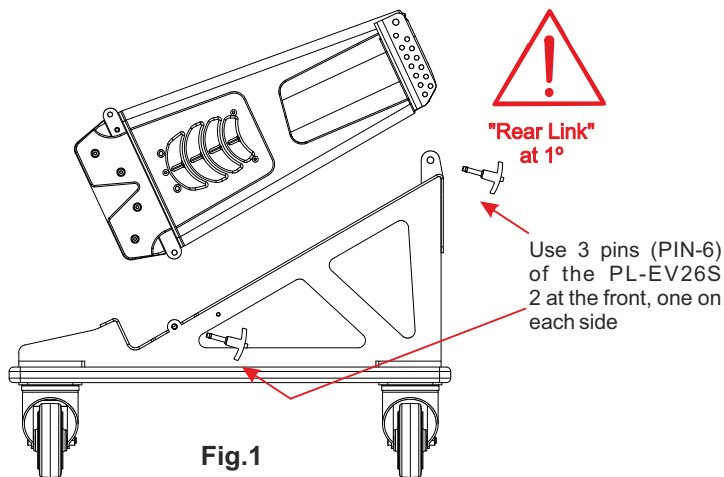

Fig.1

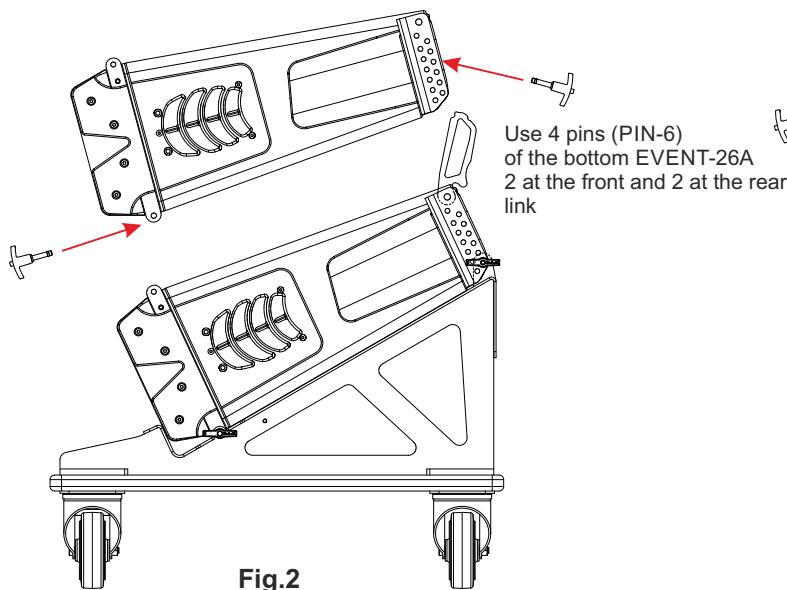

Fig.2

When transporting the systems is recommended to insert one of the pins in the 10° splay angle at the rear. By doing this the cabinets wouldn't be able to get separated from the rear.

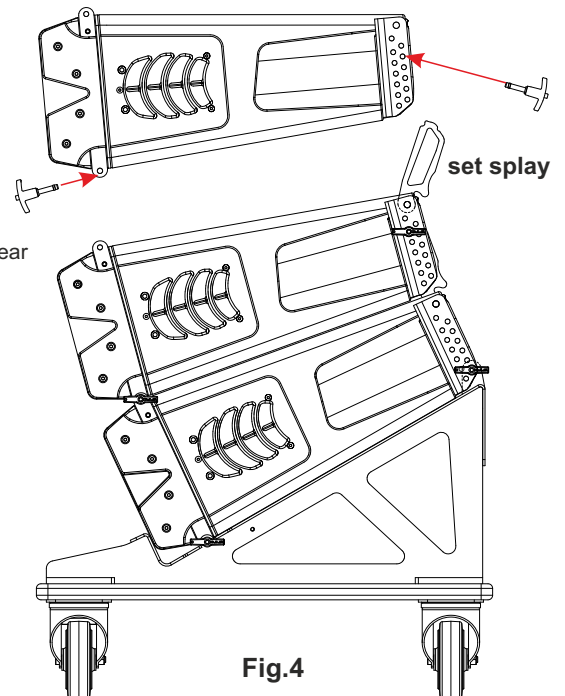
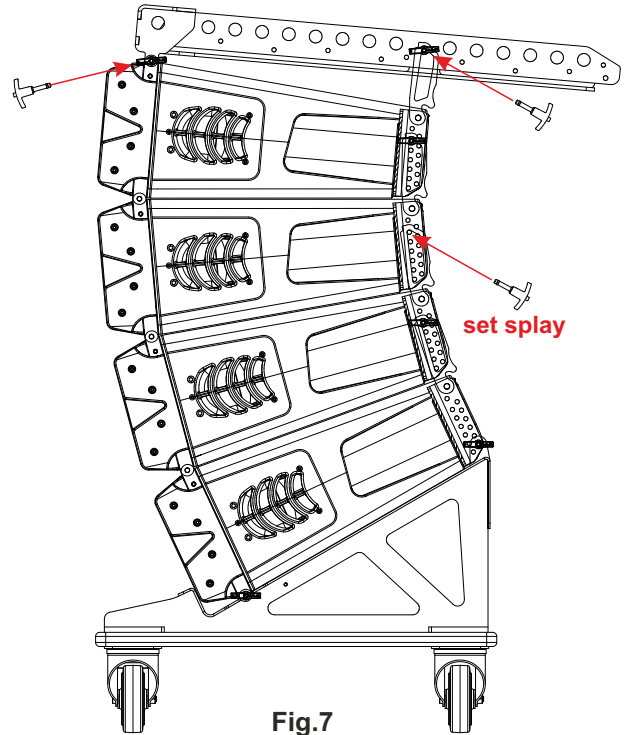
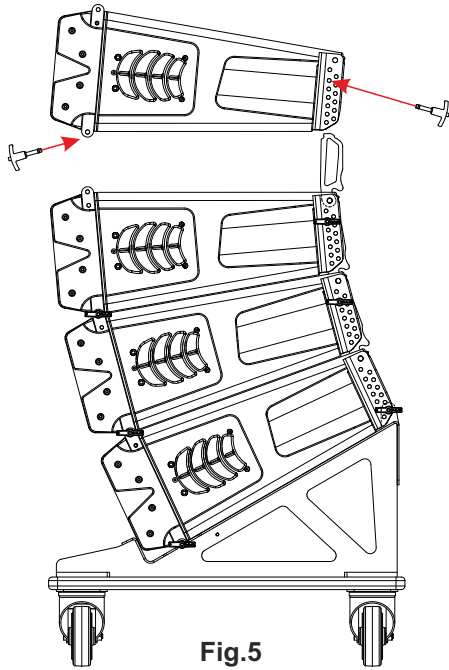

Fig.4

4 or 6 units mounting on a PL-EV26S flatbed dolly

Repeat the process shown in the previous figures with the rest of the cabinets. In this case, the set up of 4 units is shown.

Finally, the rigging bumper, AX-EV26 can be attached to the top cabinet using its available pins. insert two pins at the front and one at the rear. keep the extra pin stored in the cabinet.



At this point the cover for 4 units could be placed to protect them during transportation:

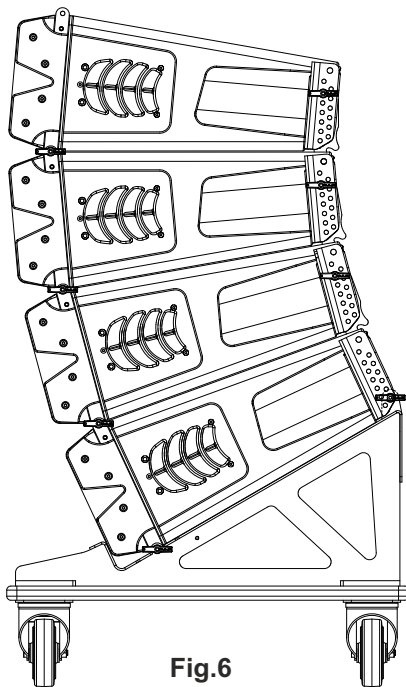

Array mounting of groups of 4 units on a flatbed dolly

Groups of to 4 or 6 units are easy to transport by truck.

We will see in this section the assembly of an array system with groups of four units previously placed on the PL-EV26S dollies.

The first group with 4 units will be the superior group, that is to say, the group where we will install the AX-EV26.

To assembly the AX-EV26, first, remove the cover from the stack and use the pins of the top cabinet.



Insert the pins of the top cabinet in the dedicated holes of the AX-EV26, as shown in the figure 8 (3 pins are needed).

Next step would be running an Ease Focus simulation in order to know the different splay angles between the units and the pick up position. (pin point of the central bar).

Before attaching the chain hoist to the AX-EV26, the user should be able to vary the splay angles between units and modify them accordingly to the Ease Focus 3 simulation.

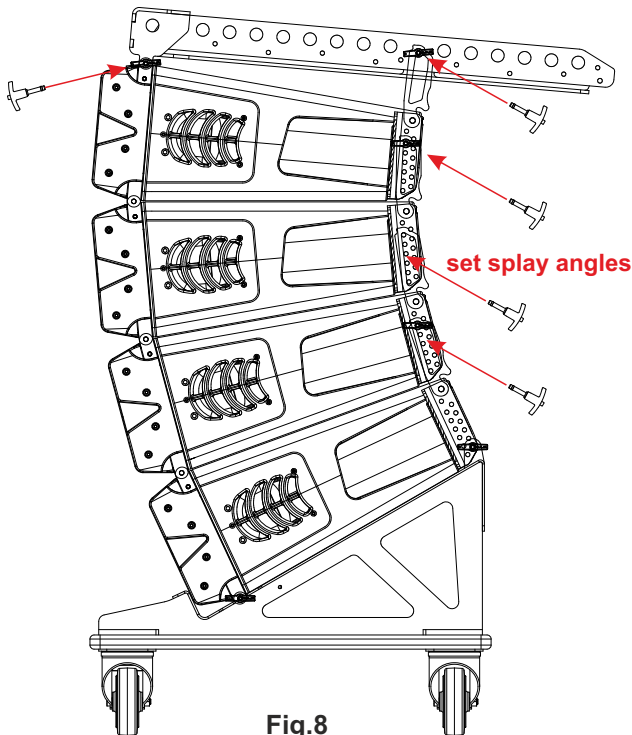
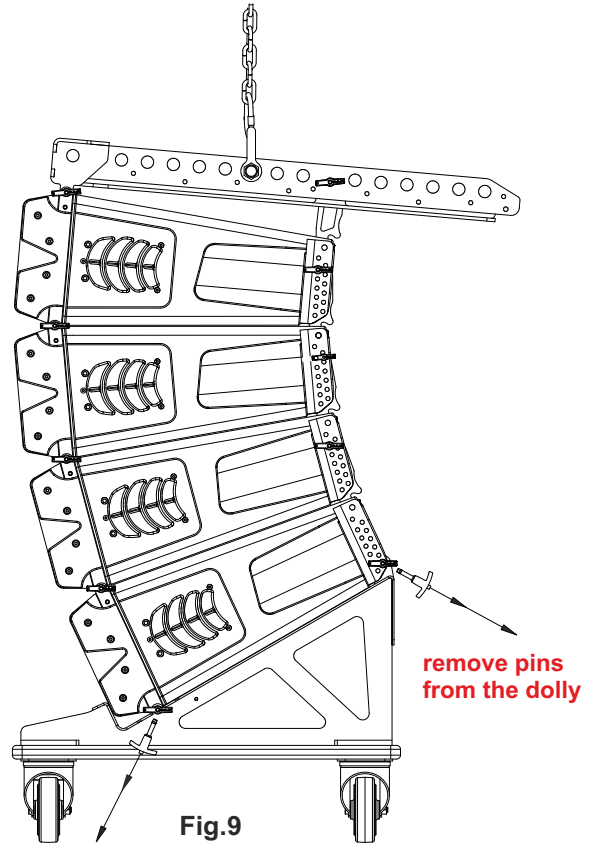

Fig.8

Set the splay angles between the units accordingly to the Ease Focus Project. In this case 0° , 2° and 4° .

Warning: Verify the correct installation of the security pins. These pins will support the inferior load.

Fix the shackle in the pin point hole of the AX-EV26 determined by the Ease Focus 3 project and remove the pins that attach the bottom cabinet to the dolly before lifting the system.



Array mounting of groups of 4 units on a flatbed dolly

Rise the system and splay angles between cabinets will be set automatically:

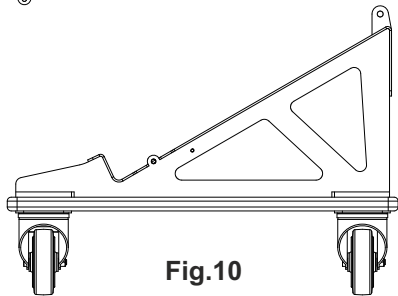
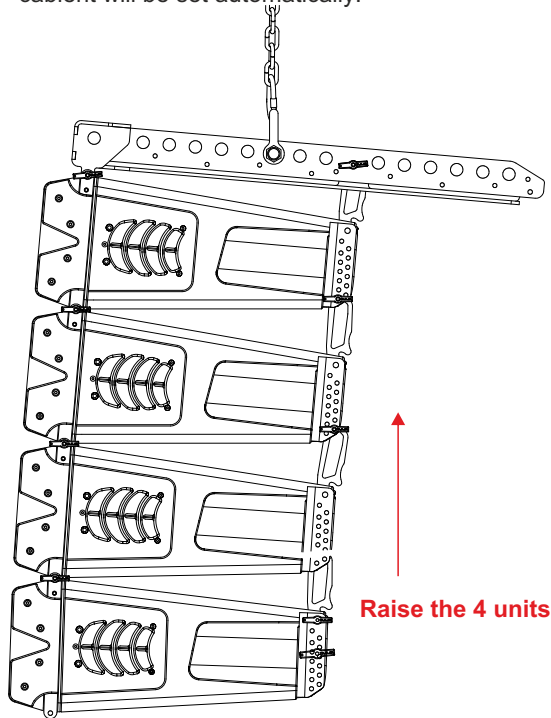

Fig.10

NOTE: To rig the system the simplest approach is using three pins (two at the front and one at the rear). With this method the splay angle between units is set automatically while the cabinets are lifted up.

If the user needs to lock the splay angle between the units, an extra pin (pin number 4), has to be inserted in the rear structure in hole named "splay+1°".

Repeat the process with the second dolly. Lower the first four units, set splay angle in the ones stacked on the dolly, attach the two groups and rise it. In the sample shown only three pins per cabinet are used:

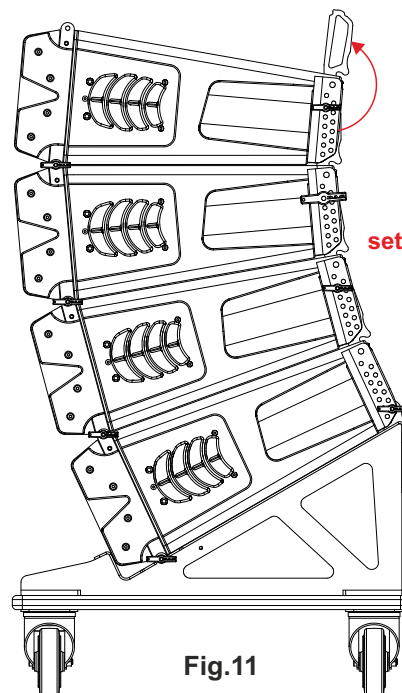
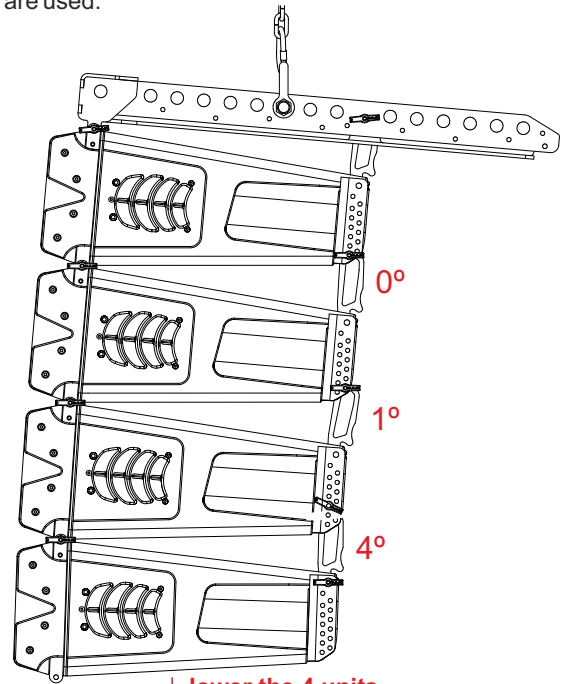
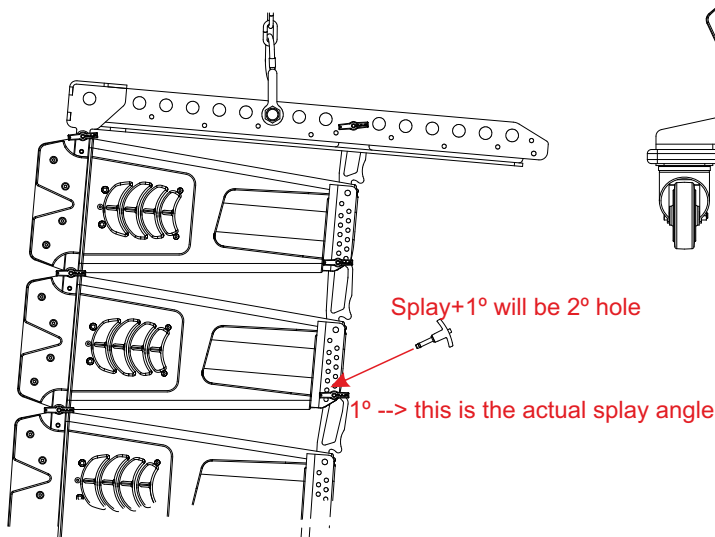

Fig.11



EVENT-115A Array mounting

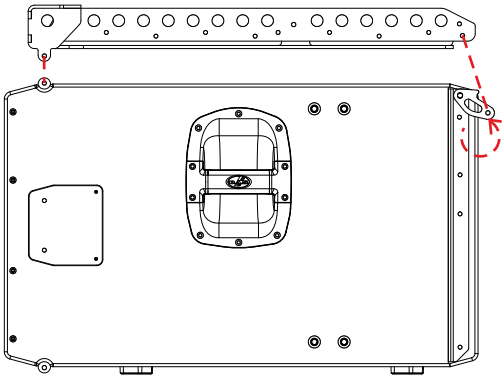

Fig.12

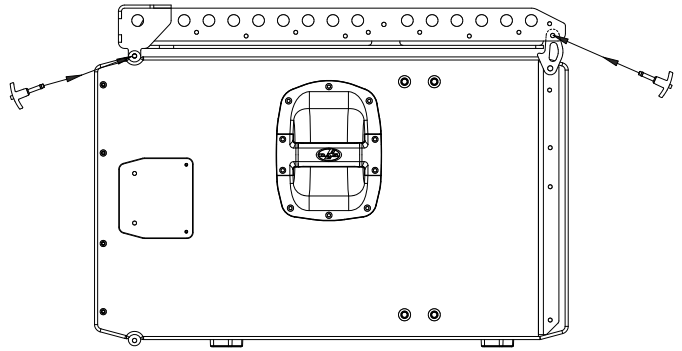

Fig.13

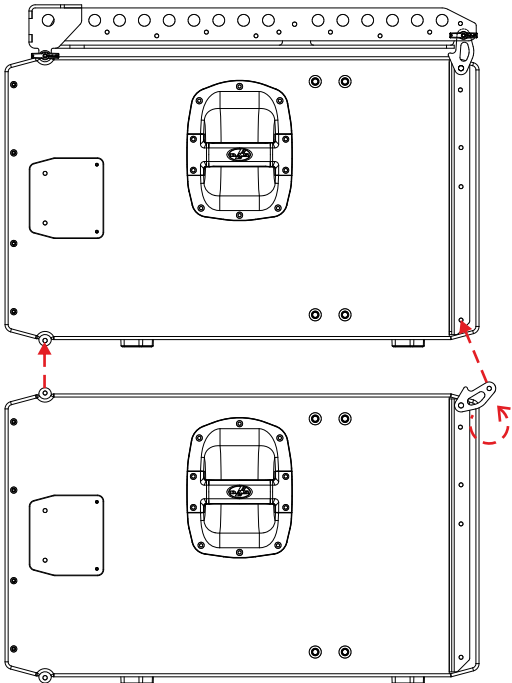

Fig.14

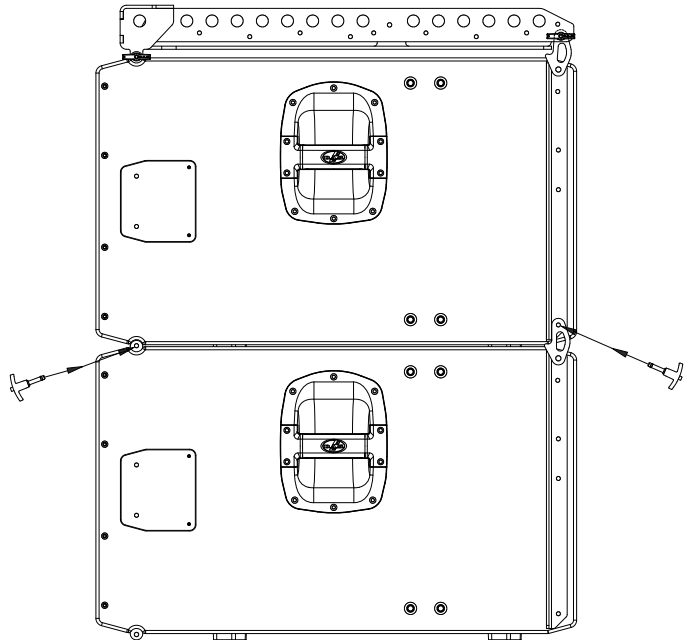

Fig.15

EVENT-26A Array mounting “one by one”

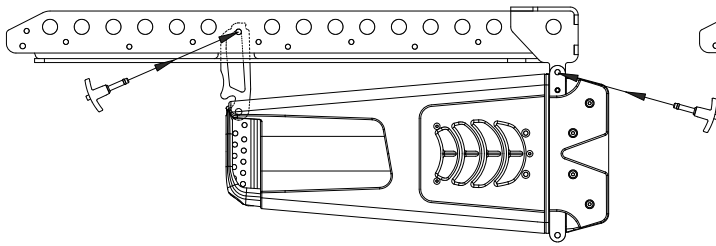

Fig.16

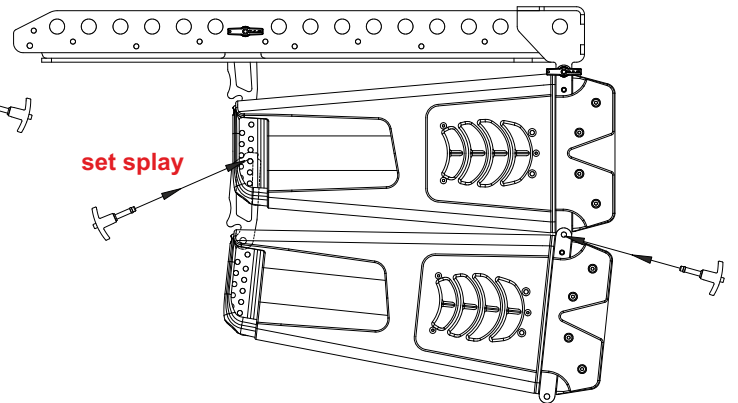

Fig.17

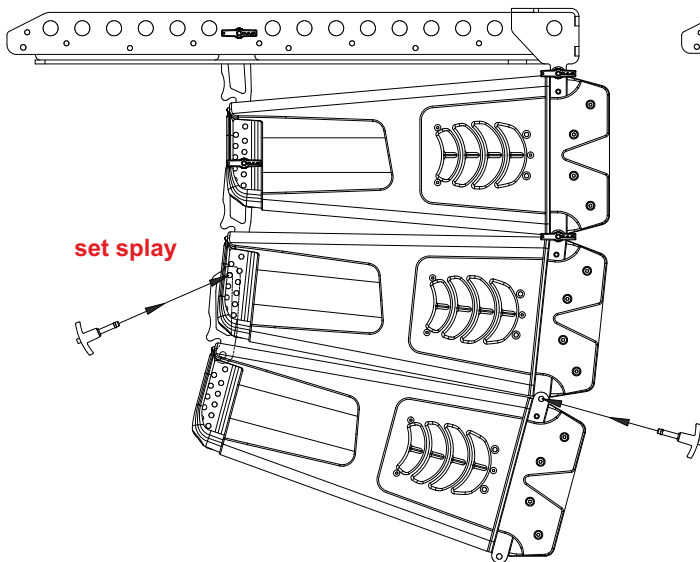

Fig.18

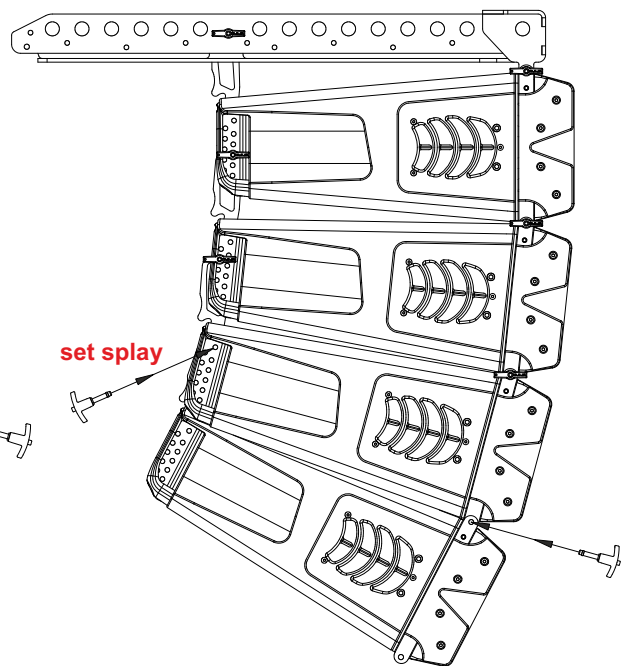
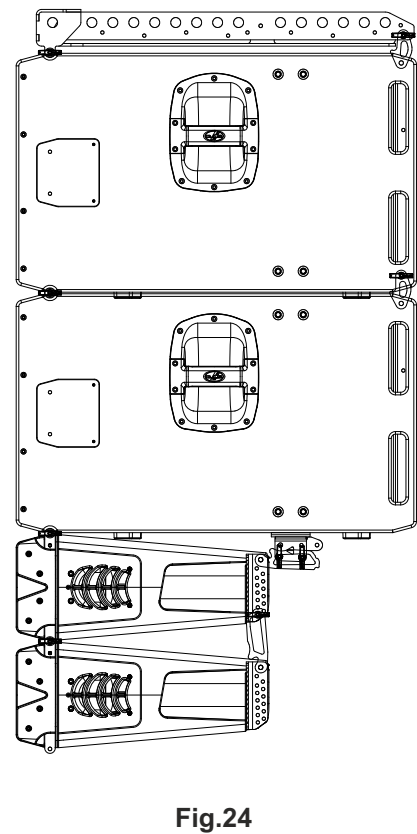
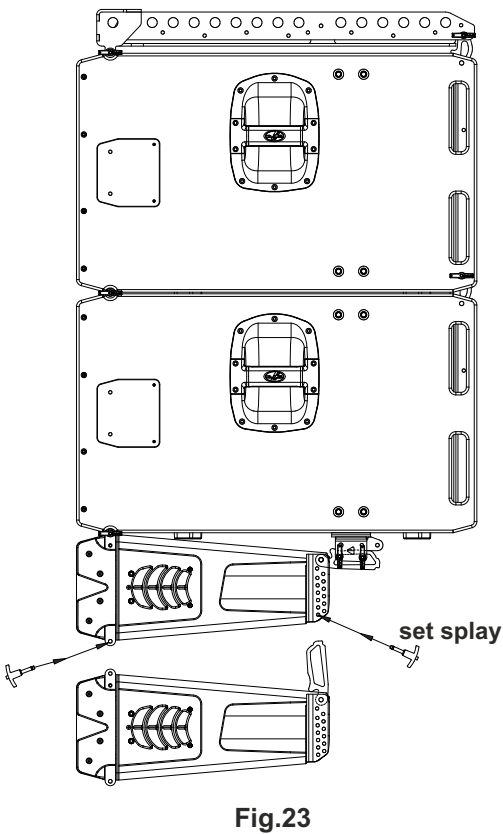
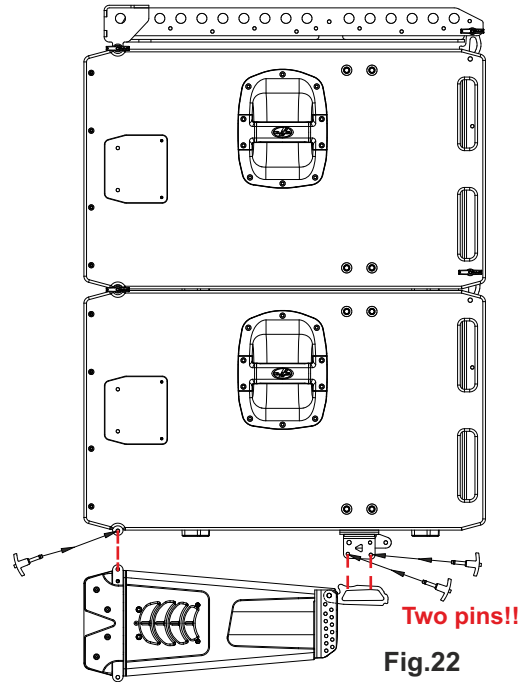
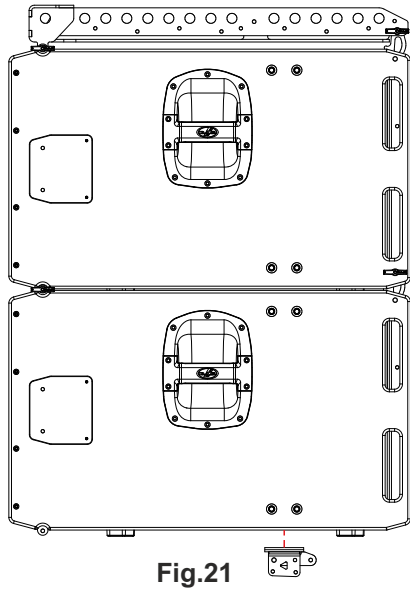
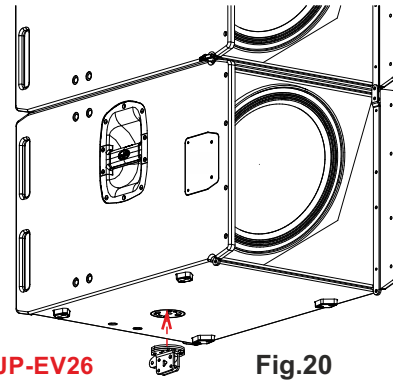

Fig.19

EVENT-115A + EVENT-26A Array mounting

First step will be assembling the subwoofers with the AX-EV26. follow the process shown on previous pages.

Next step, before hanging the EVENT-26A units is to fix to the bottom EVENT-115A the joining plate JP-EV26.



Stacking EVENT-26A on EVENT-115A

JP-EV26 joining plate is needed to stack the systems.

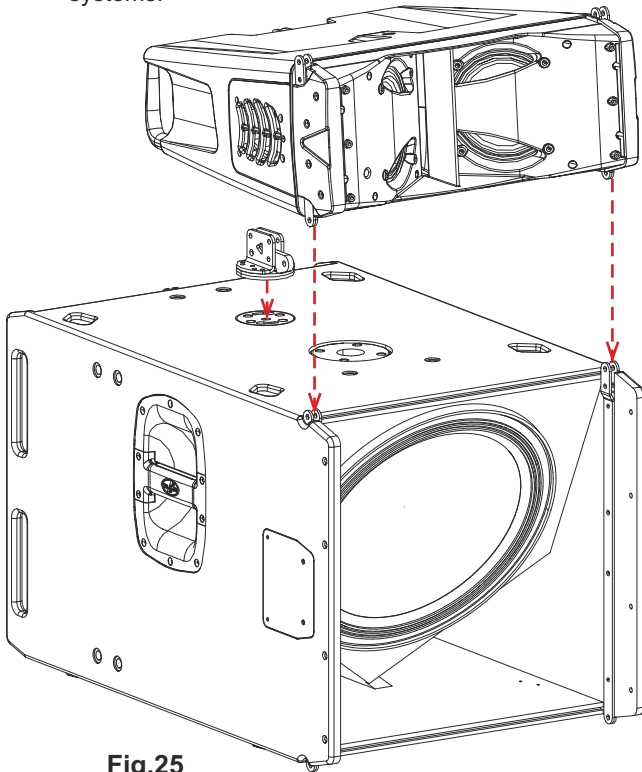

Fig.25

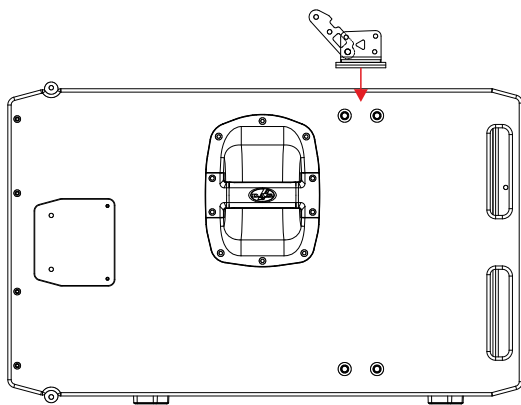

Fig.26

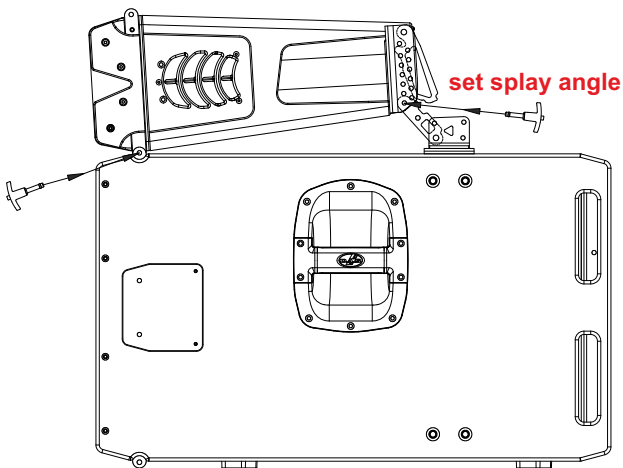

Fig.27

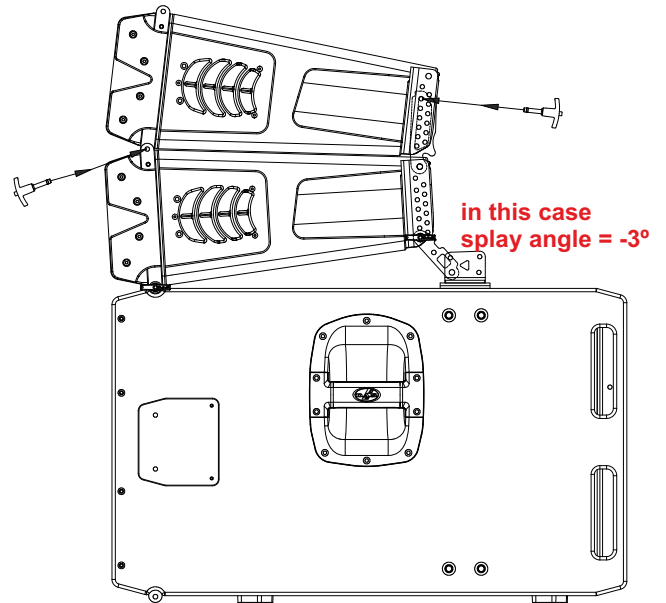

Fig.28

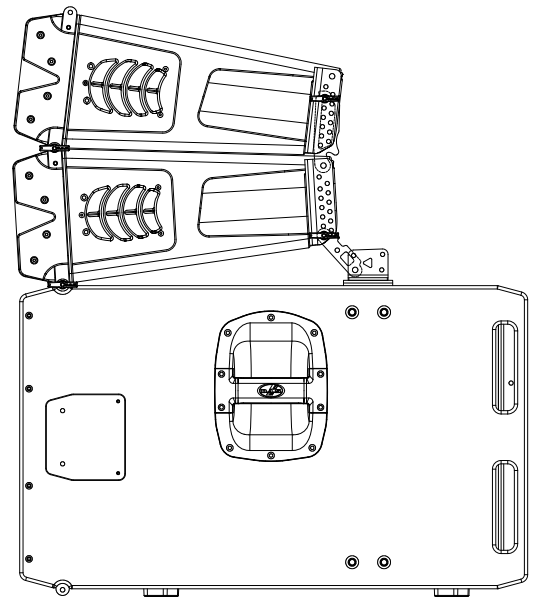

Fig.29

Angle between first EVENT-26A and EVENT-115A:

Cam link Hole - real splay angle

- 9° = +4°
- 8° = +4°
- 7° = +2°
- 6° = +2°
- 5° = 0°
- 4° = 0°
- 3° = -2°
- 2° = -2°
- 1° = -3°
- 0° = -3°

Stacking EVENT-26A on AXS-EV26

When using the AXS-EV26 to stack the system on a tripod TRD-2 or TRD-7 pole mount and AXC-ZT accessory is also needed.

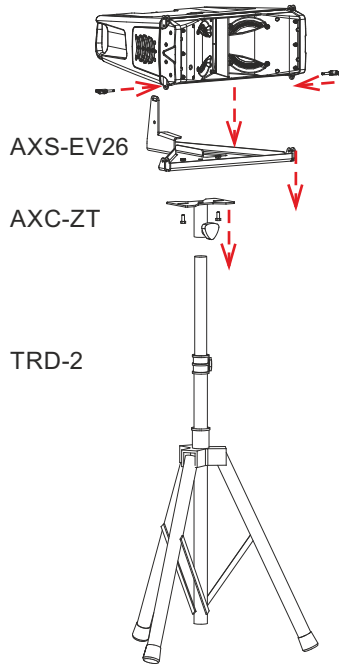
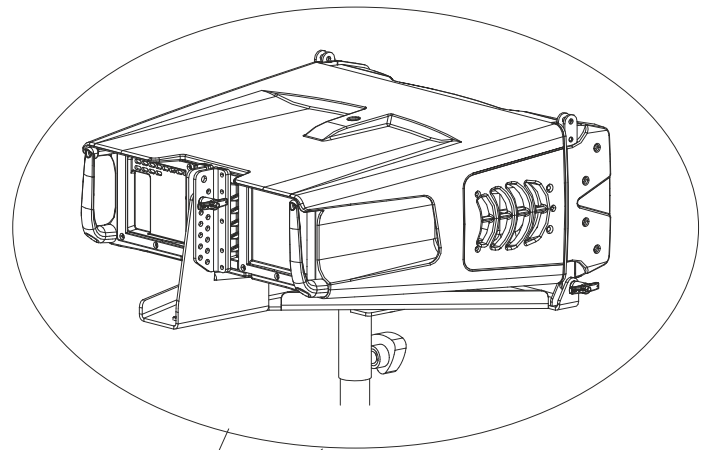

Fig.30



Rear View - Detail

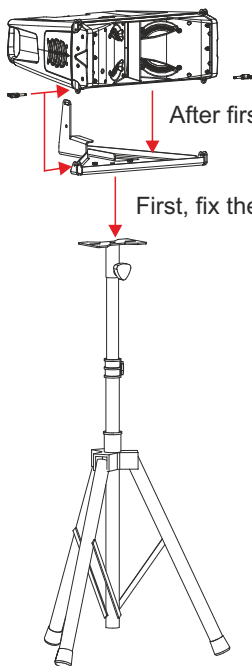
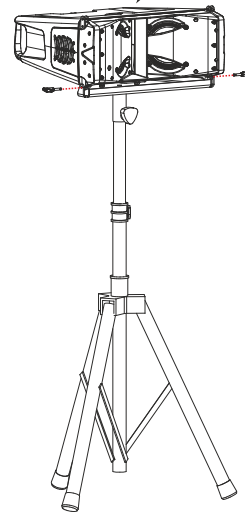

Fig.31



Transportation

As a compact system, 8 tops and 4 subs can be transported in a small van:

Note: EVENT-208A/210A/218A/121A EVENT-26A and EVENT-115A (EV-26A & EV-115A in the images)

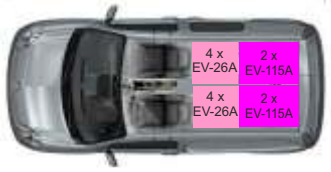

Euro truck

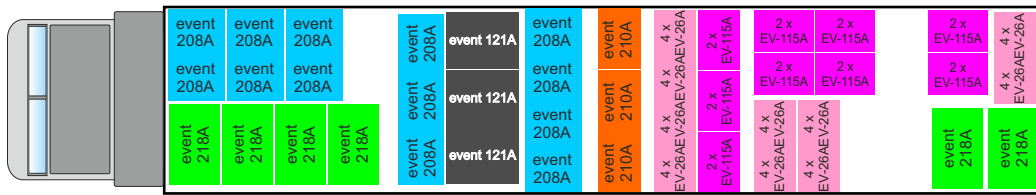

243cm / 96"

American truck



228cm / 90"

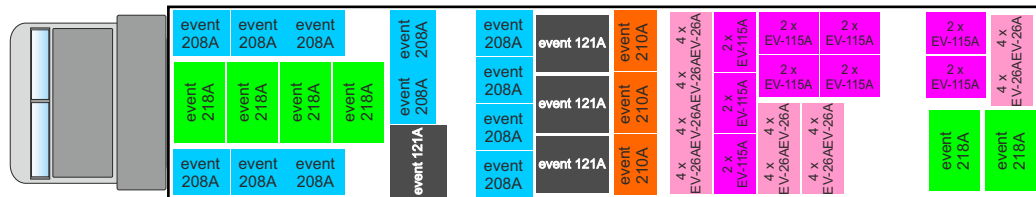

251cm / 90"

ANNEX : Line connections: unbalanced and balanced

There are two basic ways to transport an audio signal with microphone or line level:

Unbalanced line: Utilising a two conductor cable, it transports the signal as the voltage between them. Electromagnetic interference can get added to the signal as undesired noise. Connectors that carry unbalanced signals have two pins, such as RCA (Phono) and 1/4" (6.35mm, often referred to as jack) mono. 3 pin connector such as XLR (Cannon) may also carry unbalanced signals if one of the pins is unused.

Balanced line: Utilising a three conductor cable, one of them acts as a shield against electromagnetic noise and is the ground conductor. The other two have the same voltage with respect to the ground conductor but with opposite signs. The noise that cannot be rejected by the shield affects both signal conductors in the same way. At the device's input the two signals get summed with opposite sign, so that noise is cancelled out while the programme signal doubles in level. Most professional audio devices use balanced inputs and outputs. Connectors that can carry balanced signal have three pins, such as XLR (Cannon) and 1/4" (6.35mm) stereo.

The graphs that follow show the recommended connection with different types of connectors to balanced processor or amplifier inputs. The connectors on the left-hand side come from a signal source, and the ones on the right hand side go to the inputs of the processor or amplifier. Note that on the unbalanced connectors on the left-hand side, two terminals are joined inside the connector. If hum occurs with balanced to balanced connections, try disconnecting the sleeve (ground) on the input connector. Note that the illustrations show what should be connected to what, but that pin locations on an actual XLR connector are different. Also, pin 2 hot is assumed on XLR connectors.

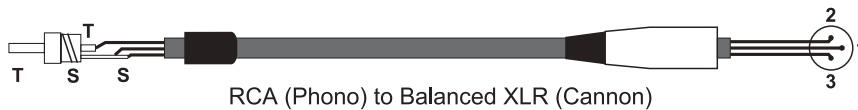
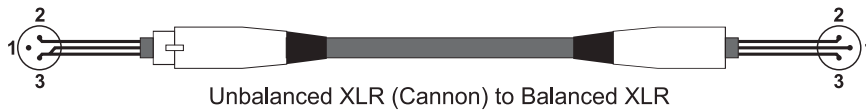
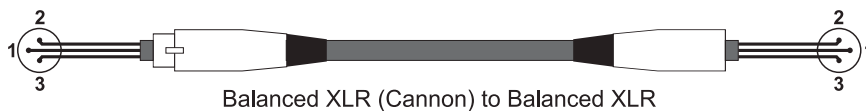



www.dasaudio.com

UM_EV3_01_EN