

**VOX**

# **Jam VOX**

**Jam and Practice Tool for Guitar**

**Effect guide**



# Table of contents

<b>A. AMP Models</b> .....	<b>1</b>
Controlling Factors .....	1
About the Gain and Volume knobs .....	2
Virtual Valve Reactor .....	2
Tube Talk .....	3
Power Amp Accuracy .....	3
1. VOX AC15 .....	3
2. VOX AC15TB .....	4
3. VOX AC30 .....	4
4. VOX AC30TB .....	4
5. UK BLUES .....	4
6. UK 68P .....	5
7. UK '80S .....	5
8. UK '90S .....	5
9. UK MODERN .....	5
10. BLACK 2X12 .....	5
11. TWEED 1X12 .....	6
12. TWEED 4X10 .....	6
13. BOUTIQUE CL .....	6
14. BOUTIQUE OD .....	6
15. US MODERN .....	7
16. US HIGAIN .....	7

17. UK MODERN2 .....	7
18. BOUTIQUE METAL .....	7
19. MODDED OD .....	7

<b>B. Cabinet Models</b> .....	<b>8</b>
Cabinet and speaker accuracy .....	8
1. VOX AC15 .....	8
2. VOX AC30 .....	8
3. VOX AD412 .....	8
4. VOX AD120VTX .....	8
5. UK H30 4X12 .....	9
6. UK T75 4X12 .....	9
7. BLACK 2X10 .....	9
8. BLACK 2X12 .....	9
9. TWEED 1X8 .....	9
10. TWEED 1X12 .....	9
11. TWEED 4X10 .....	9
12. US V30 4X12 .....	9
What goes with what? .....	10
Some recommendations .....	11

**C. Pedal Effects ..... 12**

- 1. TUBE OD ..... 12
- 2. SUPER OD ..... 12
- 3. ORANGE DIST ..... 13
- 4. METAL DIST ..... 13
- 5. FAT DIST ..... 14
- 6. FUZZ ..... 14
- 7. OCTAFUZZ ..... 14
- 8. TREBLE BOOST ..... 15
- 9. BOUTIQUE ..... 15
- 10. VOLUME ..... 15
- 11. VOX WAH ..... 16
- 12. AUTO WAH ..... 17
- 13. COMP ..... 18
- 14. ACOUSTIC ..... 19
- 15. OCTAVE ..... 20
- 16. BLK/ORG PHASE ..... 21
- 17. U-VIBE ..... 22
- 18. RING MOD ..... 23

**D. Noise Reduction ..... 24**

- 1. NOISE REDUCTION ..... 24

**E. Modulation Effects ..... 25**

- 1. CLASSIC CHORUS ..... 25
- 2. MULTI TAP CHORUS ..... 26
- 3. STEREO CHORUS ..... 27
- 4. BI CHORUS ..... 28
- 5. CLASSIC FLANGER ..... 29
- 6. DUO PHASE ..... 30
- 7. FILTRON ..... 31
- 8. PITCH SHIFTER ..... 32
- 9. TEXTREM ..... 33
- 10. ROTARY ..... 34
- 11. MOD DELAY ..... 35
- 12. TALK MOD ..... 36

**F. Delay Effects .....37**

- 1. STEREO DELAY ..... 37
- 2. CROSS DELAY ..... 38
- 3. 2TAP DELAY ..... 39
- 4. RHYTHM DELAY ..... 40
- 5. HOLD DELAY ..... 41
- 6. REVERSE DELAY ..... 42
- 7. MOD DELAY ..... 43
- 8. SWEEP DELAY ..... 44
- 9. ANALOG DELAY ..... 45
- 10. MULTI HEAD ..... 46
- 11. ECHO PLUS ..... 47

**G. Reverb Effects .....48**

- 1. SLAP ..... 48
- 2. GATE ..... 49
- 3. SPRING ..... 50
- 4. BOUNCE ..... 50
- 5. PLATE ..... 50
- 6. GARAGE ..... 51
- 7. CHAMBER ..... 51
- 8. CANYON ..... 51
- 9. ROOM ..... 52
- 10. STUDIO ..... 52
- 11. HALL ..... 52
- 12. ARENA ..... 53

**Block Diagram .....53**



## A. AMP Models

Which amps did we painstakingly model for our exquisite selection of 19? Believe us when we say it wasn't easy 'cos, as I'm sure you know, there's a plethora of great sounding amps out there. After countless hours of soul searching, earnest discussions, calls to tone-wise friends (some professional players, some not...but all blessed with great ears) plus, of course, listening and playing, a top 19 list was finally drawn up. As you're about to discover, the ones we went with are not only the cream of the crop but also offer up the widest possible array of the greatest guitar tones known to man — from pristine clean to outrageous overdrive and all points in-between. First though, some stuff you should know...

### Controlling Factors

As already touched on in this manual, although the amp model of your JamVOX houses controls for GAIN, VR GAIN, TREBLE, MIDDLE, BASS, PRESENCE and OUTPUT, not all of the amps we've modelled have as many controls. In such cases, rather than leave you with knobs that do nothing (what on earth would be the point of that!?), we've made full use of all seven (7) JamVOX controls *without* compromising the accuracy of any of our models. This means you'll be able to mimic the full tonal spectrum of each and every one of the originals we've modelled...and then some, thanks to the extra flexibility and additional control the seven JamVOX controls give you.

For example, if an original amp doesn't have a complete 3 band EQ network then we'll set up the "missing" tone controls on our model to be "neutral" (i.e. as the original) when set at 12 o'clock — thus giving you extra tonal flexibility in those EQ areas, if you so wish. Just so you know, the amps we modelled that don't have individual controls for Treble, Middle and Bass are:

Amp	Original tone controls
VOX AC15	Top Cut & Bass Cut Switch
VOX AC15TB	Treble & Bass
VOX AC30	Top Cut only
VOX AC30TB	Treble, Bass and Cut
TWEED 1x12	Just one, called Tone!

Also, as you'd probably expect, we do the same exact thing with the JamVOX's PRESENCE control too — namely, if one isn't present (bad pun, not intended!) on the original then PRESENCE will be an added control on our model. This time though, the "neutral" position is when the control is all the way off (turned fully counterclockwise). The two models this applies to are BLACK 2x12 and TWEED 1x12.

#### IMPORTANT NOTE:

As you'll discover when you read their descriptions, in the case of the AC15, AC15TB, AC30 and AC30TB models, we've utilized the PRESENCE control to mimic the TOP CUT control — whether it was present on the original or not.

### About the Gain and Volume knobs

JamVOX's amp models provide three programmable knobs that affect the volume (gain); GAIN, VR GAIN, and OUTPUT. Each control has its own specific job, and the sound of a particular amp model can vary over an amazingly wide range just depending on the settings of these knobs.

As some of you will know, most vintage amps only have one VOLUME control to set up the sound, whilst more modern amps usually have two types of level controls — GAIN (or sometimes PREAMP VOLUME) that controls the input level of the preamp section, and MASTER VOLUME that controls how much signal is (and how loud it is going to be) passed from the preamp to the power amp. With many vintage amps there is no MASTER VOLUME, the preamp feeds directly into the power amp without any type of control.

The JamVOX's controls are designed to cover all these points:

**JamVOX GAIN:** On vintage type models that do not have a master volume (i.e., AC15, AC15TB, AC30, AC30TB, UK BLUES, UK 68P, BLACK 2x12, TWEED 1x12, TWEED 4x10), the GAIN control works like the VOLUME of the original amp. On models that do have a master volume, the GAIN control works like GAIN or PREAMP VOLUME.

**JamVOX VR GAIN:** MASTER VOLUME that controls how much preamp signal level is passed to the power amp, which in our case is the VIRTUAL VALVE REACTOR stage. (Your JamVOX works like a real amp.)

**JamVOX OUTPUT:** For want of a better way of putting it, this is like a power attenuator that you would add between the output of your amp and the input of your speaker cabinet.

As in how the original amps work, we have made the relationship between preamp and power amp work in the same way. Therefore to obtain truly authentic tones please use the VR GAIN control in the same way, i.e. with VINTAGE type models that do not have Master Volume control's, turn the VR GAIN control up to maximum.

When using a model of a modern amp that does have a master volume control, adjust VR GAIN just as you would adjust the master volume control. Low settings of VR GAIN will tend to produce more of a preamp distortion, while high settings will add the distinctive distortion and warmth of the Valve Reactor.

Lastly, if an original amp features a unique switch or control we make sure that we cover it! Such things will be revealed in the model descriptions that follow shortly...

### Virtual Valve Reactor

Valve Reactor technology was first used in the VOX AD60/120VT amps. In the ToneLab series, this consisted of a low-wattage tube power amp circuit, a virtual output transformer that used solid-state components to emulate an output transformer, and a dummy speaker circuit that simulated the impedance changes of a speaker. Virtual Valve Reactor turns this Valve Reactor technology completely into software, simulating the same circuit structure as a real full-tube amp.

## Tube Talk

Us Brits call 'em valves while our US cousins call 'em tubes...as the saying goes: England and America are merely two countries divided by a common language! Anyway, call 'em what you will, these wondrous glass bottles lie at the tonal heart of each of our 19 models. As all the amps we've modelled hail from one of the two countries just mentioned, in honour of their heritage, the descriptions of all English amps will employ the words "valve" and "valves," while the American ones will be tubular!

**QUESTION:** What's the difference between an ECC83 preamp valve and a 12AX7 preamp tube?

**ANSWER:** Nothing! They're the same exact thing — namely the most popular preamp tube in ampland. ECC83 is the British name, 12AX7 (a.k.a. 7025) is the American. See, I told you we were two countries divided by a common language!

## Power Amp Accuracy

What happens in the power stage of any good tube amp is of *paramount importance* to the way the amp sounds, feels and behaves. The way the power amp operates (Class A or Class AB), the power tubes used (EL84s, EL34s, 6L6s, 6V6s), the exact nature of the negative feedback loop circuitry (if one even exists) and how the power stage interacts (a relationship called damping) with the speaker(s) it is driving — all these things play a vital role in the creation of *tone*. That is why we have fitted your JamVOX with our **Virtual Valve Reactor Technology** — a modelling breakthrough that is unique to VOX and infuses our critically acclaimed Valvetronix range of amps with life and feel. This revolutionary technology emulates a tube power-amp and ensures that all the important bases inherent in a tube amp are faithfully and accurately covered. For example: if you choose amp model AC30TB — an amp with a Class A power stage, EL84 output tubes and no negative feedback, that's exactly what your *Virtual Valve Reactor* power amp reconfigures itself to be.

This all said, let's take a look at each of our amp models...

### 1. VOX AC15

This is based on Channel 2 of a 1962 1x12, 15 Watt VOX AC15 which only has three controls — Volume, Brilliance and Top Cut. JamVOX's GAIN control mimics the original's Volume control, while the PRESENCE control acts as the Top Cut.\* The BASS control acts as the Bass Cut with total variability. Set the "extra" TREBLE and MIDDLE controls at 12 o'clock and they're "neutral" or tweak them for extra tonal flexibility.

**Original's valve compliment:** 1 x EF86, 3 x ECC83s, 1 x ECC82 in the preamp, 1 x EZ81 rectifier, 2 x EL84s in the power amp.

**\*CONTROL NOTE:**

The original AC15's Top Cut control works in the opposite way you'd expect — it "cuts" when you turn it up! You'll be glad to read that our Top Cut control (the PRESENCE knob) works in a much more logical fashion — turn it up for more "sparkle," turn it down for less.

### 2. VOX AC15TB

The AC15TB is a modern-day amp which combines the tonal characteristics of the AC15's low Wattage power stage, with the increased tonal flexibility that the Top Boost (TB) channel of an AC30 has to offer. Then, to sweeten the pot even further, a 12" Celestion "Blue" speaker, Reverb and a Master Volume control were thrown in too. The original has two tone controls—Treble and Bass. So, as is the norm, the JamVOX's TREBLE and BASS controls mimic their namesakes while the MIDDLE ("neutral" at 12 o'clock) and PRESENCE add further tonal flexibility. To ensure maximum "Voxiness," we've made sure that the PRESENCE control behaves exactly like the "Top Cut" on the original AC15 — except in reverse ("off" = cut) to make it more logical, just like on our AC15 model. In trademark VOX fashion, our AC15TBX model oozes clean tones that "jangle" and "chime," while its overdrives are smooth yet pulsating with desirable harmonic overtones.

**Original's valve compliment:** 5 x ECC83s in the preamp, 1 x 5Y3GT rectifier, 2 x EL84s in the power amp.

### 3. VOX AC30

This amp is based on the Normal channel of a 1959 30 Watt, 2x12, AC30. The AC30's Normal channel boasts the bare minimum of knobs — Volume and Top Cut (GAIN and PRESENCE\* respectively).

**Original's valve compliment:** 4 x ECC83s, 1 x ECC82 in the preamp, 1 x GZ34 rectifier, 4 x EL84s in the power amp.

#### \*CONTROL NOTE:

Once again, our PRESENCE control styles the "Top Cut" on the original AC30 exactly — except in reverse ("off" = cut) to make it more logical, just like on our AC15 model.

### 4. VOX AC30TB

The Brilliant channel of an AC30TB includes extra tone circuitry that features an additional ECC83 valve called "Top Boost" and two extra EQ controls, giving the amp three tone controls — Treble, Bass and Cut. Once again, the PRESENCE control of our model acts as the original's Cut (but in reverse: "off" = cut) while the GAIN, TREBLE and BASS mimic the original's Volume, Treble and Bass controls. The MIDDLE is an "extra" with 12 o'clock being its "neutral" position. Our AC30TB produces clean sounds that are rich and jangly with a smooth yet detailed top end, and overdrives that have a glorious, throaty bark — just like those classic, "Class A" tones.

**Original's valve compliment:** 5 x ECC83s & 1 x ECC82 in the preamp, 1 x GZ34 rectifier, 4 x EL84s in the power amp.

### 5. UK BLUES

Our UK BLUES is based on the "High Treble" channel of an extremely rare, handwired head made in England in the early '60s. Although the TWEED 4x10 circuit was used as a basic template for this amp, several fundamental changes (e.g. different tubes, different transformers, a higher output impedance and vastly different speakers in a closed-back cab), give UK BLUES its own unique and highly desirable character.

**Original's valve compliment:** 3 x ECC83s in the preamp, 1 x GZ34 rectifier, 2x KT66s in the power amp.

## 6. UK 68P

This is based on the “High Treble” channel of a 4 input, 1968, 50 Watt, all-valve head. It doesn’t feature a Master Volume control so the best way to set it up is to max out the volume! To achieve the same response as the original, remember to turn the VR GAIN control to maximum. The JamVOX works EXACTLY like the original. So, wind the GAIN control all the way up and immerse yourself in an instantly recognizable, organic overdrive that responds beautifully to the subtle dynamics of your playing. Rolling back your guitar’s volume control results in a unique and highly usable clean sound.

**Original’s valve compliment:** 3 x ECC83s in the preamp, 2 x EL34s in the power amp.

## 7. UK ‘80S

This is based on a 1983, all tube, single channel 100 Watt head that boasts a Master Volume control. Invariably played with its (preamp) Gain control cranked, this amp will provide a fat, roaring sound. Although UK ‘80s became famous for its distinctive, cranium-crushing crunch, it isn’t merely a “one trick pony” and neither is our model—just like the original, when you roll back your guitar’s volume knob you’ll get a bright, clean sound that’s perfect for chord work and will cut through any mix.

**Original’s valve compliment:** 3 x ECC83s in the preamp, 4 x EL34s in the power amp.

## 8. UK ‘90S

This model is based on the “lead” channel of a 100 Watt, dual channel head that is capable of so much preamp distortion it houses a Gain control that goes all the way up to 20! This amp replaced UK ‘80s and was developed to satisfy the ever-evolving rock guitarists’ insatiable lust for more gain, features and flexibility.

**Original’s valve compliment:** 3 x ECC83s in the preamp, 4 x 5881s in the power amp.

## 9. UK MODERN

This is based on the High Gain channel of a modern, all-tube 100 Watter that is effectively a hybrid of the UK ‘80s and UK ‘90s amps. It combines the toneful high gain preamp stage and modern features of UK ‘90s with the unmistakable, “snarling” punch and girth the UK ‘80s power stage had to offer.

**Original’s valve compliment:** 4 x ECC83s in the preamp, 4 x EL34s in the power amp.

## 10. BLACK 2X12

The dual channel, BLACK 2X12’s clean sound is very tight “n” twangy, with a deep, taut, piano-like bass. When pushed hard the bass tends to crumble. So, to emulate this classic, BLACK 2x12 overdrive, here’s what you dial in on your JamVOX: full GAIN and VR GAIN, not much BASS, full MIDDLE and set TREBLE to taste. Because the EQ network of BLACK 2x12 lies before the main gain stage of its preamp, pushing the mids in this way emphasizes the distortion in that frequency range and the result is a lovely, singing blues tone. As already mentioned elsewhere, the original amp doesn’t have a Presence control but does have a Bright Switch. The PRESENCE control on your JamVOX emulates this switch when “off” and “on,” plus all points in-between!

**Original’s tube compliment:** 2 x 12AX7s & 2 x 7025s & 2 x 12AT7s (a.k.a. ECC81) in the preamp, 4 x 6L6s in the power amp.

**TONAL HINT:** BLACK 2x12 is the perfect partner for ACOUSTIC (Acoustic Guitar Simulator) in the Pedal effect.

### 11. TWEED 1X12

The TWEED 1x12, 18 Watt, all-tube combo is the very essence of simplicity with a Volume knob and a single Tone control. This Tone control is merely a treble cut and boost, and its behavior can be mimicked by using the JamVOX's TREBLE, MIDDLE and BASS EQ network as follows:

Original Tone control turned all the way down (off) = BASS on full; TREBLE and MIDDLE at 9 o'clock (PRESENCE "off").

Original Tone control turned up "full" (on 10) = TREBLE on full; MIDDLE and BASS at 9 o'clock (PRESENCE "off").

**Original's tube compliment:** 1 x 12AY7, 1 x 12AX7 in the preamp, 1 x 5Y3GT rectifier, 2 x 6V6s in the power amp.

**NOTE:** As the original doesn't have a Presence control, PRESENCE is "neutral" when "off," but can be used to add "extra" sparkle and cut to the style if you so wish.

### 12. TWEED 4X10

TWEED 4x10 is very sensitive and responsive to both picking strength and the volume setting on your guitar. This means that by backing-off your axe's volume when the amp is cranked, you can produce a beautifully clean and full tone. It also means that dynamic picking control allows you to make notes or chords more distorted or clean than others, depending on how hard or how soft you pick. Another cool tonal quirk of TWEED 4x10 is the classic, vintage tube amp sag its GZ34 rectifier tube adds to your notes whenever the amp is driven really hard.

**Original's tube compliment:** 1 x 12AY7, 2 x 12AX7s in the preamp, 1x GZ34 rectifier, 2 x 5881s in the power amp.

### 13. BOUTIQUE CL

For this amp, we styled the Clean channel of another very expensive, handwired, custom amp made by the same boutique builder as BOUTIQUE OD. Its beautifully rounded low-end, delightfully transient midrange attack and sweet treble make it the perfect partner for single-coil pickups. It is also incredibly responsive and extremely sensitive to picking styles and pickup selection. And, as an added bonus, strummed chords just ring out and blossom.

**Original's tube compliment:** 3 x 12AX7s in the preamp, 4 x 6L6s in the power amp.

### 14. BOUTIQUE OD

For this one we styled the Overdrive channel of a very rare and expensive 100 Watt head named the Overdrive Special. This hand-wired beauty has a spectacular overdriven sound that's pxxerfect for sax-like, legato soloing. With its GAIN control wide-open, BOUTIQUE OD produces a stunning sustain which is very smooth and very soulful.

**Original's tube compliment:** 3 x 12AX7s in the preamp, 4 x EL34s in the power amp.

## 15. US MODERN

This is based on the “Modern High Gain” channel of a 100 Watt, head from California. Its deep, dark, loose low-end, some what “fizzy” top and Monster-like gain has made this amp a mainstay for many modern, acts. At low GAIN settings, it produces a distinctive, bright clean sound bolstered by some rich, upper harmonics that add fullness and dimension.

**Original’s tube compliment:** 5 x 12AX7s in the preamp, 2 x 5U4G rectifier tubes, 4 x 6L6s in the power amp.

## 16. US HIGAIN

This is based on the Overdrive Channel of an all-tube, 100 Watt snakeskin head. US HIGAIN is capable of a powerful, heavily saturated sound that combines an open low-end with compressed mids and highs. The result is a tone that remains focused and well defined at even the most extreme gain settings.

**Original’s tube compliment:** 4 x 12AX7s in the preamp, 4 x 6L6s in the power amp.

## 17. UK MODERN2

This model is based on a 100-watt UK-made head made in 1996 for a famous lead guitarist known for his incredible tone, slashing rhythms and a penchant for top hats. This all-tube amp’s footswitchable “Lead Master” control effectively made this a two-channel amplifier. This amp also featured a push/pull function on the input gain control which, when pulled out, injects a distorted edge to the amp’s rhythm tone. If you have an appetite for great metal lead and rhythm tones, this is a great choice for you!

**Original tube complement:** 3 x 12AX7, 4 x EL34

## 18. BOUTIQUE METAL

The original amp we modeled for this devastating hi-gain sound is a German-made 4-channel head that churns out 100 watts of mayhem. This head features four individual preamps, each with individual EQ and gain/volume controls. For our model, we chose the “Heavy” channel for its incredible tightness when playing drop-D (and lower) metal.

**Original tube complement:** 7 x 12AX7, 4 x 6L6

## 19. MODDED OD

This model captures the sound of a 100-watt boutique head made in North Hollywood, CA. This amp head is available in EL34 and 6L6-powered versions. For our model, we chose the 6L6 and modeled “Channel 2.” This amplifier has the ability to be switched between Class A/B and Class A modes. For our model, we selected Class A/B operation for its rich harmonic response and musical response.

**Original tube complement:** 6 x 12AX7, 4 x 6L6

## B. Cabinet Models

Now let's look at the CABINET models:

### Cabinet and speaker accuracy

There's not much point in having incredibly accurate amp models if the speaker cabinet models on offer aren't of the same exacting standards. As you may know, in real life, the output stage of a tube amp works in close harmony with the varying impedance curve of the speaker(s) it is driving. This intimate and vital relationship plays a major role in producing the warm, punchy sound and pleasing feel that we all know and love. In a nutshell, modelling a speaker cabinet is not just a case of frequency response, but is a combination of frequency response, transient response (how a speaker reacts to the strength of how a note is played), and the all-important interaction of the amps output to the speaker's impedance curve. In addition, other vitally important factors that have to be taken into account when modelling a cabinet are the actual physical dimensions of the enclosure (cabinet), the unique tonality of said enclosure (which will be affected by both the type and thickness of the wood it is made of) and whether it boasts an open, semi-open or closed-back design. Special circuitry and unique modelling technology ensures that all of these factors are well taken care of in the cabinet models built into your JamVOX.

### 1. VOX AC15

This is a 1x12" open backed combo using the famed VOX Blue Alnico speaker, manufactured by Celestion in England.

### 2. VOX AC30

These original 2x12" VOX Blue Alnicos, are wired in series for 16 Ohms, and add even more of that great VOX tone.

### 3. VOX AD412

This cabinet is one of VOX's latest products, and due to the fact we are extremely proud of it, and that it is without a doubt an exceedingly great sounding cabinet, we just had to include it with our cabinet models. The cabinet itself features custom designed Celestion speakers using Neodymium magnets, one of the first, if not the first, cabinet to use this technology. It also uses some special cabinet acoustic design technology that is also a first for VOX and 4x12s in general. Use it as a valid tonal option with any model, but especially the amp head models. We think you will like it!

### 4. VOX AD120VTX

This is a closed back cabinet containing two 12 inch custom-designed Celestion speakers with Neodymium magnets.



### **5. UK H30 4X12**

This heavy-duty cabinet with 30 Watt speakers, from the late '60s is made by the same famous UK amp company as the UK T75 4x12.

### **6. UK T75 4X12**

This 4x12" closed-back cabinet is loaded with modern, 75 Watt British speakers.

### **7. BLACK 2X10**

These speakers are based on an open backed 2x10" ceramic magnet 35 Watt combo.

### **8. BLACK 2X12**

This speaker system features two 12" Ceramic magnet speakers. They are 8 Ohm units wired in parallel for a 4 Ohm total load.

### **9. TWEED 1X8**

The 8-inch 3.2-ohm Alnico speaker in this cabinet is built into a simple, open-backed amp with a 6V6 output valve.

### **10. TWEED 1X12**

This speaker is the other half of our Tweed 1x12 Amp. As the name suggests it is a single 12" speaker, which uses a revered Alnico magnet.

### **11. TWEED 4X10**

Keeping with Alnico magnet speakers, this cabinet is open backed and uses four 10" 8 Ohm speakers, wired in parallel for a total of 2 Ohms impedance.

### **12. US V30 4X12**

This black beast of a cabinet uses four UK made "Vintage" named speakers and is known for it's deep bass and high end detail.

### What goes with what?

Basically, with your JamVOX you can mix any amp model to any cabinet model, and create many varied tones. But to give you a starting point, here is a listing of historically correct matches. You can select these combinations from the amp/cabinet combination catalog that appears when you click the amp/cabinet name located above the effect routing.

Combination	Amp model	Historically correct cabinet model
VOX AC15	AC15	VOX AC15
VOX AC15TB	AC15TB	VOX AC15
VOX AC15TWIN	AC15	VOX AC30
VOX AC30	AC30	VOX AC30
VOX AC30TB	AC30TB	VOX AC30
UK BLUES	UK BLUES	UK H30 4x12
UK 68P	UK 68P	UK H30 4x12
UK 80's	UK 80's	UK T75 4x12
UK 90's	UK 90's	UK T75 4x12
UK MODERN	UK MODERN	UK T75 4x12 or US V30 4x12
BLACK 2X12	BLACK 2X12	BLACK 2x12
TWEED 1x12	TWEED 1x12	TWEED 1x12
TWEED 4x10	TWEED 4x10	TWEED 4x10
BOUTIQUE OD	BOUTIQUE OD	UK H30 4x12 is a good choice
BOUTIQUE CLN	BOUTIQUE CLN	UK H30 4x12 is a good choice
US MODERN	US MODERN	US V30 4x12
US HIGAIN	US HIGAIN	US V30 4x12 or UK T75 4x12
UK MODERN2	UK MODERN2	UK T75 4x12
BOUTIQUE METAL	BOUTIQUE METAL	UK H30 4x12
MODDED OD	MODDED OD	VOX AC30

## Some recommendations

As some of the manufacturers of the original amps that we modelled also used similar amps with different speaker configurations to make other models, so can you with your JamVOX to approximate these other amps. For instance:

Amp Model	Cabinet Model	Equivalent Model
BLACK 2x12	BLACK 2x10	Blackface Vibrolux type combo
BLACK 2x12	TWEED 4x10	Blackface Super type combo
TWEED 1x12	BLACK 2x10	Tweed Super type combo
UK BLUES	VOX AC30	Early BluesBreaker type combo

Please note that these amps will be approximations only as original power ratings, output transformers and speaker manufacturer and types, might have been different in the original products.

Due to the flexibility of your JamVOX, mixing and matching all of the amp and cabinet models can be done with the turn of a switch, without any risk of blowing the speakers up. Something that cannot be done in real life (unfortunately!). This capability can lead to some very interesting combinations, some useful, perhaps some not, but only you can decide what is useful to you, as your tone requirements are unique. Please feel free to explore all combinations of amps and cabinets. That is the beauty of JamVOX.

**NOTE:** Proceed with caution, since JamVOX or your speakers may be damaged if you misuse the unit. A seemingly endless number of combinations of the amp and cabinet models is available. Try out many combinations until you find your “soul mate” sound! There are no rules regarding the combination of amp and cabinet models. Just use your own “free” and “creative” mind to seek out your own sonic cosmos!

**NOTE:** Product names appearing in this manual are trademarks of their respective owners, which are not associated or affiliated with VOX in any way. (except for VOX of course!!) Names and descriptions of these products are provided only for the purpose of identifying specific products that were studied by VOX in the course of developing this product.

## C. Pedal Effects

These are a variety of pedal effects such as distortion, modulation, and ring modulator. You can choose one of eighteen types.

Parameters marked with  can be controlled by an optional Korg EXP-2 foot controller connected to the JamVOX monitor.

For details on how to assign a parameter to the foot controller, refer to “Option pedal/switch settings” (☞JamVOX owner’s manual p. 32).

### 1. TUBE OD

This model is based on an overdrive pedal that’s housed in a garish, “seasick green” box and is considered an all-time classic due to the wonderfully warm tones it produces.



**DRIVE** 

Adjusts the amount of distortion (boost).

[1.0...10.0]

**LEVEL** 

Adjusts the output level.

[0.0...10.0]

**STONE** 

Adjusts the tone.

[1.0...10.0]

### 2. SUPER OD

This models a yellow overdrive pedal manufactured in Japan, and is popular as a booster.

The parameters are the same as for TUBE OD (See “TUBE OD” on page 12).



### 3. ORANGE DIST

This models a classic distortion unit manufactured in Japan and packaged in an orange box. The parameters are the same as for TUBE OD (See “TUBE OD” on page 12).



### 4. METAL DIST

This distortion model is perfect for the “metal head” in you!

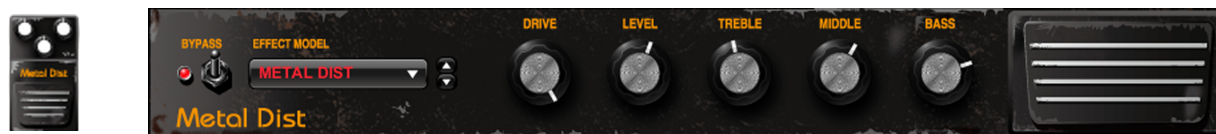

#### DRIVE

Adjusts the amount of distortion.

[1.0...10.0]

#### LEVEL

Adjusts the output level.

[0.0...10.0]

#### TREBLE

Adjusts the high-range volume level.

[0.0...10.0]

#### MIDDLE

Adjusts the mid-range volume level.

[0.0...10.0]

#### BASS

Adjusts the low-range volume level.

[0.0...10.0]

## 5. FAT DIST

Based on a pedal named after one of the most disliked rodents to ever walk the planet! The result is a smooth distortion rich in harmonics...nasty but nice.

The parameters are the same as for TUBE OD (See "TUBE OD" on page 12).



## 6. FUZZ

Retro, rude "n" raw...get the picture!? The name says it all.

The parameters are the same as for TUBE OD (See "TUBE OD" on page 12).



## 7. OCTAFUZZ

This models a legendary fuzz unit that adds a pitch one octave above the original. To get the best results, be sure to use your front pickup.

The parameters are the same as for TUBE OD (See "TUBE OD" on page 12).



## 8. TREBLE BOOST

This pedal effect is modelled after a built-in treble booster that was designed with the VOX VBM-1 specifically in mind. It is a great way of adding “teeth” to an overdriven sound. The parameters are the same as for TUBE OD (See “TUBE OD” on page 12).



## 9. BOUTIQUE

This models an overdrive unit named after a half-human half-horse creature appearing in Greek fables. When the gain is lowered, you can use this as a booster that does not impair the original tonal character of your guitar. Raising the gain lets you use this as an overdrive that delivers a rich mid-range. The 12 o'clock position is the standard setting for tone, but feel free to adjust this aggressively.

The parameters are the same as for TUBE OD (See “TUBE OD” on page 12).



## 10. VOLUME

This models the VOX V850 volume pedal.



**LEVEL** 

Adjusts the volume level.

[0.0...1.0]

### 11. VOX WAH

This effect is modeled on two legendary VOX wah pedals; the V847 and the V848 Clyde McCoy model. Thanks to their unique “throaty” tone, these are the only wah pedals many professionals will consider stepping on.



#### **CLOSE**

Adjusts the tone when the wah pedal is closed.

[1.0...10.0]

#### **OPEN**

Adjusts the tone when the wah pedal is open.

[1.0...10.0]

#### **MANUAL**

Adjusts the openness (position) of the wah.

[1.0...10.0]

#### **TYPE**

Selects either V847 or V848 Clyde McCoy model as the wah type.

[V847, V848]

**USEFUL TONE HINT:** A great tonal trick that’s employed by many guitarists, including some who are household names, is to find a “sweet spot” within the range of their Wah pedal and then leave it there. This is often called stuck-Wah (imagine that!) and, when used tastefully, can be very effective as it produces a very distinctive sound that will cut through any mix. You can dial in a stuck-Wah “sweet spot” with your TONE control in a heartbeat. Try it, it’s cool...

**NOTE:** If you select VOX WAH as the pedal effect, “MANUAL” will automatically be assigned to the optional Korg EXP-2 foot controller connected to the JamVOX monitor.



## 12. AUTO WAH

The lazy man's Wah pedal! Only kidding...this quirky but useful effect allows you to create an automatic Wah effect that varies with your picking dynamics (i.e. how hard or soft you hit the strings). As in VOX WAH, you can select either V847 or V848 as the wah type.



### SENS

Adjusts the sensitivity with which the wah responds to the volume of the guitar.

[0.0...10.0]

### POLARITY

Sets the direction in which the auto wah will operate.

[UP, DOWN]

### ATTACK

Adjusts the Auto Wah's response speed.

[1.0...10.0]

### TYPE

Selects either V847 or V848 Clyde McCoy model as the wah type.

[V847, V848]

### 13. COMP

Gotta play a clean passage that needs to be nice, smooth and even? Need a hair more sustain on a lead line? Then, look no further; COMP is the pedal for you. Modelled on a compressor pedal that is hugely popular due to the percussive clean sound it can produce — making it perfect for '80s and '90s pop and funk rhythm work. It can also add a singing, mellow sustain to lead lines — clean or dirty.



#### SENS

[1.0...10.0]

Adjusts the sensitivity of the compressor (i.e. when its “smoothing” effect kicks in). The amount of compression/sustain will increase the more you turn this control up.

#### LEVEL

[0.0...10.0]

Adjusts the output level.

## 14. ACOUSTIC

Wanna go “unplugged” without the hassle of switching guitars and amps? Enter the acoustic guitar simulator — a clever effect that magically converts an electric guitar’s sound into that of an acoustic. It works best with a single coil (read: low output) pickup in the neck position, especially when paired with the BLACK 2x12 amp model.



### BODY

Adjusts the resonance of the body selected via the “TYPE” parameter.

[1.0...10.0]

### BASS

Adjusts the bass.

[0.0...10.0]

### TREBLE

Adjusts the treble.

[0.0...10.0]

### TYPE

Selects the type of body.

[1...4]

- 1: M-SMALL Small-size, old body suitable for delicate arpeggio technique.
- 2: G-SMALL Small-size body that features a unique mid range loved by country blues players.
- 3: T-LARGE Large-size body that features a sophisticated sound suitable for pop music.
- 4: RESO Body suitable for a resonator guitar for playing slide.

## 15. OCTAVE

This effect generates a note one or two octaves lower than the one you're playing, adding thickness and "weight" to single note lines.



### **DIRECT**

Adjusts the level of the original note.

[0.0...1.0]

### **1 OCTAVE**

Adjusts the mix level of the note one octave below.

[0.0...1.0]

### **2 OCTAVE**

Adjusts the mix level of the note two octaves below.

[0.0...1.0]

**WARNING!** Like all pedals of this type, OCTAVE *only* works with single notes...chords confuse the heck out of it! NOT a fault — that's just the way these pedals operate.

## 16. BLK/ORG PHASE

This models three models of phaser; a wide-range four-stage phaser that was made in Denmark and packaged in a black box, a popular four-stage phaser that came in a banana-colored box, and a mild-sounding ten-stage phaser that was likewise banana-colored. Use the TYPE knob to select the model.



### SPEED

Adjusts the modulation speed.

[0.100...10.00 Hz]

### DEPTH

Adjusts the modulation depth.

[0.0...10.0]

### RESONANCE

Adjusts the amount of resonance.

[0.0...10.0]

### MANUAL

Adjusts the center frequency of the sweep. “MANUAL” has no effect if “DEPTH” is set to 10.0.

[1.0...10.0]

### TYPE

Selects the type of phaser.

[BLK, ORG1, ORG2]

**BLK:** Danish four-stage phaser with a wide range.

**ORG1:** Popular four-stage phaser in a banana-colored box.

**ORG2:** Sophisticated-sounding ten-stage phaser in a banana-colored box.

### 17. U-VIBE

Modeled on the famous phase/vibrato pedal effect unit. This effect simulates a rotating speaker and produces a wonderfully seductive and “watery” tone. Interestingly enough, the guy responsible for this great pedal is also responsible for the birth of the remarkable Valve Reactor Technology.



#### **SPEED**

Adjusts the speed of the Uni-Vibe effect.

[1.00...10.00 Hz]

#### **DEPTH**

Adjusts the depth of the Uni-Vibe effect.

[0.0...10.0]

#### **MIX**

Adjusts the mixture of direct sound and vibrato.

[0.0...10.0]

**NOTE:** If you assign “SPEED” to an optional Korg EXP-2 foot controller connected to the JamVOX monitor, you’ll be able to use the foot controller to control the vibrato speed in the same way as on a pedal phase/vibrato unit. (See JamVOX owner’s manual “Option pedal/switch settings” on page 32)

## 18. RING MOD

A ring modulator is an effect that uses an oscillator to generate a sine wave which is then multiplied with the signal from your guitar to produce harmonics above and below the frequencies originally produced by your guitar. This creates complex and unpredictable pitches. A filter is built into the output of this effect to let you extract just the lower frequencies if desired, and this can generate low sounds that could not otherwise be produced by a guitar.



### DIRECT

Adjusts the amount of original sound that is mixed in.

[0.0...10.0]

### EFFECT

Adjusts the effect volume.

[0.0...10.0]

### FILTER

Adjusts the filter cutoff frequency.

[1.0...10.0]

### MANUAL

Adjusts the oscillator frequency.

[0.0...10.0]

**NOTE:** If you assign “MANUAL” to an optional Korg EXP-2 foot controller connected to the JamVOX monitor, you’ll be able to produce some extremely unique effects. (See JamVOX owner’s manual “Option pedal/switch settings” on page 32)

## D. Noise Reduction



### 1. NOISE REDUCTION

#### **SENSITIVITY**

**[OFF, 0.2...10.0]**

Adjusts the sensitivity of the noise reduction. Increasing this value will produce more noise reduction. Normally you will adjust this so that you do not hear obtrusive noise when the strings are lightly muted.

**NOTE:** If the value is raised excessively, the notes may be cut off unnaturally. If this occurs, reduce the value.



## E. Modulation Effects

Here you can make settings for a modulation effect. You can choose one of twelve types.

Parameters marked with  can be controlled by an optional Korg EXP-2 foot controller connected to the JamVOX monitor.

Parameters marked with  can be controlled by an optional VOX VFS-2 foot switch connected to the JamVOX monitor.

For details on how to assign a parameter to the foot controller or foot switch, refer to “Option pedal/switch settings” (See JamVOX owner’s manual “Option pedal/switch settings” on page 32).

### 1. CLASSIC CHORUS

**Mono in/Mono out 1 (Mode=1,3), Mono in/Mono out 3 (Mode=2)**

This models a chorus unit that has two modes (chorus and vibrato), and is best-known for being built into a guitar amp. There’s no parameter to switch between chorus and vibrato, but you can use the “SPEED and “DEPTH” knobs to create either of these sounds, giving you an even broader range of possibilities than the original unit! The output vibrato mode allows you to create vibrato (pitch modulation) by outputting just the effect sound.



#### **SPEED**

Adjusts the modulation speed.

[0.100...10.00 Hz]

#### **DEPTH**

Adjusts the modulation depth.

[0.0...10.0]

#### **MANUAL**

Adjusts the center frequency of the sweep. “MANUAL” has no effect if “DEPTH” is set to 10.0.

[1.0...10.0]

#### **MODE**

Selects the output mode.

[1, 2, 3]

1: Mono output.

2: Stereo mode in which the effect is panned right, and the dry sound panned left.

3: Vibrato mode, in which only the effect sound is output. Setting “MANUAL to 10.0 will minimize the delay of the output sound.

## 2. MULTI TAP CHORUS

Stereo in/Stereo out 1

This model features independent chorus taps for each of the left, center and right outputs, producing a feeling of depth and spaciousness.



### SPEED

Adjusts the modulation speed.

[0.100...10.00 Hz]

### DEPTH

Adjusts the modulation depth.

[0.0...10.0]

### TIME

Adjusts the delay time.

[0.0...10.0]

### MIX

Adjusts the mix amount of the effect.

[0.0...10.0]

### 3. STEREO CHORUS

Mono in/Stereo out 1

A stereo chorus in a yellow case. A sense of stereo is created by inverting the phase of the effect sound for the right output, producing a feeling of spaciousness that is somewhat different than the stereo effect of CLASSIC CHORUS.



#### SPEED

Adjusts the modulation speed.

[0.100...10.00 Hz]

#### DEPTH

Adjusts the modulation depth.

[0.0...10.0]

#### MANUAL

Adjusts the center frequency of the sweep. "MANUAL" has no effect if "DEPTH" is set to 10.0.

[1.0...10.0]

#### MIX

Adjusts the mix amount of the effect sound.

[0.0...10.0]

## 4. BI CHORUS

**Mono in/Mono out 1 (Mode=SERIAL), Stereo in/Stereo out 1 (Mode=PARA1, PARA2, PARA3)**

This is a chorus model unique to VOX. It provides two chorus units, CHORUS 1 and CHORUS 2, and lets you connect the two units not only in series or in parallel, but also to synchronize or de-synchronize the two LFOs. It produces a variety of tones that cover a range from wonderfully spacious sounds to bizarre flanger-like sounds with complex modulation.



### SPEED1

Adjusts the modulation speed of CHORUS 1.

[0.100...10.00 Hz]

### DEPTH

Adjusts the modulation depth of CHORUS 1/2.

[0.0...10.0]

### RESONANCE

Adjusts the amount of resonance for CHORUS 1/2.

[0.0...10.0]

### SPEED2

Adjusts the modulation speed of CHORUS 2.

[0.100...10.00 Hz]

**NOTE:** This will not function if “MODE” is set to **PARA2** or “**PARA3**”.

### MODE

[SERIAL, PARA1, PARA2, PARA3]

Specifies the connection and LFO for CHORUS 1/2.

**SERIAL:** CHORUS 1/2 are connected in series.

**PARA1:** CHORUS 1/2 are connected in parallel (Stereo mode).

**PARA2:** CHORUS 1/2 are connected in parallel, and their LFOs are synchronized.

**PARA3:** CHORUS 1/2 are connected in parallel, and their LFOs are synchronized in opposite phase (Stereo mode).

**NOTE:** If **PARA2** or **PARA3** is selected, the speed is adjusted by the “SPEED 1”.

### MIX

Adjusts the mix amount of the effect sound.

[0.0...10.0]

## 5. CLASSIC FLANGER

Mono in/Mono out 1

A model of a truly classic analogue flanger that “unchained” a highly influential modern guitarist who many hail as the “godfather of two handed tapping.”



### SPEED

Adjusts the modulation speed.

[0.100...10.00 Hz]

### DEPTH

Adjusts the modulation depth.

[0.0...10.0]

### RESONANCE

Adjusts the amount of resonance.

[0.0...10.0]

### MANUAL

Adjusts the center frequency of the sweep. “MANUAL” has no effect if “DEPTH” is set to 10.0.

[1.0...10.0]

### OFFSET

Adjusts the starting position of the LFO.

When you defeat BYPASS, the LFO will start from the position you specify here.

[0.0...10.0]

### MIX

Adjusts the mix amount of the effect sound.

[0.0...10.0]

### LFO TRIGGER

Each time you click the switch, the LFO will be reset to the position specified by “OFFSET.”

**NOTE:** If “FLANGER (LFO TRIGGER)” is assigned to an optional VOX VFS-2 foot switch connected to the JamVOX monitor, the foot switch can control the LFO reset. (See JamVOX owner’s manual “Option pedal/switch settings” on page 32)

## 6. DUO PHASE

**Mono in/Mono out 2 (Mode=SERIAL1, SERIAL2), Stereo in/Stereo out 2 (Mode=PARA1, PARA2, PARA3)**

This is an amazing phaser that provides two six-stage phasers; PHASER 1 and PHASER 2. They can be connected in series (to make a pseudo-twelve-stage phaser!) or in parallel, and you can also synchronize or de-synchronize the two LFOs.



### SPEED1

Adjusts the modulation speed of PHASER 1.

[0.100...10.00 Hz]

### DEPTH

Adjusts the modulation depth of PHASER 1/2.

[0.0...10.0]

### RESONANCE

Adjusts the amount of resonance for PHASER 1/2.

[0.0...10.0]

### SPEED2

Adjusts the modulation speed of PHASER 2.

[0.100...10.00 Hz]

**NOTE:** This will not function if “MODE” is set to SERIAL2, PARA2, or PARA3.

### MODE

[SERIAL1, SERIAL2, PARA1, PARA2, PARA3]

Specifies the connection and LFO for PHASER 1/2.

**SERIAL1:** PHASER 1/2 are connected in series.

**SERIAL2:** PHASER 1/2 are connected in series and their LFOs are synchronized to create a pseudo-twelve-stage phaser.

**PARA1:** PHASER 1/2 are connected in parallel (Stereo mode).

**PARA2:** PHASER 1/2 are connected in parallel, and their LFOs are synchronized (Stereo mode).

**PARA3:** PHASER 1/2 are connected in parallel, and their LFOs are synchronized in opposite phase (Stereo mode).

**NOTE:** If SERIAL2, PARA2 or PARA3 is selected, the speed is adjusted by the “SPEED 1”.

## 7. FILTRON

Stereo in/Stereo out 2

This is an envelope controlled filter — a filter that opens and closes according to the guitar input.



### ATTACK

Adjusts the speed of response.

[1.0...10.0]

### DEPTH

Adjusts the depth of the effect.

[0.0...10.0]

### RESONANCE

Adjusts the amount of resonance.

[0.0...10.0]

### MANUAL

Sets the cutoff frequency. “MANUAL” has no effect if “DEPTH” is set to 10.0.

[1.0...10.0]

### POLARITY

Specifies the direction of movement.

[UP, DOWN]

### SENS

Adjusts the sensitivity of response to the guitar volume.

[0.0...10.0]

**NOTE:** If you set “DEPTH” to 0.0 and assign “MANUAL” to an optional Korg EXP-2 foot controller connected to the JamVOX monitor, you’ll be able to replicate the Korg TRAVELER pedal. (See JamVOX owner’s manual “Option pedal/switch settings” on page 32)

## 8. PITCH SHIFTER

This is a pitch shifter with a range of two octaves up or down, rivaling sophisticated rack-mounted signal processors.



### PITCH

Adjusts the pitch in 100-cent units.

[−24...+24]

### FINE

Adjusts the pitch in one-cent units.

[−50...+50]

### TRACKING

Adjusts the tracking of the pitch shifter (i.e., how closely it will follow). Shorter settings are effective if the “PITCH” setting is close to 0, and longer settings are effective if the “PITCH” setting is close to +/-24. While listening to the pitch-shifted sound, adjust this so that you do not have difficulty playing.

[10...150 ms]

### DIRECT

Adjusts the level of the direct sound.

[0.0...10.0]

### EFFECT

Adjusts the level of the effect.

[0.0...10.0]

**NOTE:** If you assign “PITCH” to an optional Korg EXP-2 foot controller connected to the JamVOX monitor, the foot controller can control the pitch. (See JamVOX owner’s manual “Option pedal/switch settings” on page 32)



## 9. TEXTREM

Stereo in/Stereo out 2

This models the popular tremolo circuit that's built into the BLACK 2x12 model. The "SPREAD" setting lets you produce a panning effect that spreads to left and right.



### SPEED

Adjusts the tremolo speed.

[1.00...10.00 Hz]

### DEPTH

Adjusts the tremolo depth.

[0.0...10.0]

### SPREAD

Adjusts the left/right spaciousness.

[0.0...10.0]

### LEVEL

Adjusts the output level.

[1.0...10.0]

## 10. ROTARY

This models a stereo rotary speaker. When you adjust the speed, it will take a certain amount of time for the specified speed to be reached — just like on an actual rotary speaker. This is because it takes several seconds for the motor that creates the rotation to accelerate or decelerate.



### SPEED1

Adjusts the rotational speed of the speaker.

[0.80...10.0 Hz]

### DEPTH

Adjusts the modulation depth.

[0.0...10.00]

### SPEED2

Adjusts the rotational speed of the speaker.

[0.80...10.0 Hz]

### ACCEL

Adjusts the time it takes for the rotational speed to change. With higher settings, the change will take more time.

[1.0...10.0]

### SPEED SW

Switches the speaker's rotation speeds ("SPEED1" and "SPEED2").

[SPEED1, SPEED2]

**NOTE:** If "ROTARY (SPEED SW)" is assigned to an optional VOX VFS-2 foot switch, you'll be able to switch between "SPEED1" and "SPEED2" by pressing the foot switch. (See JamVOX owner's manual "Option pedal/switch settings" on page 32)

## 11. MOD DELAY

Mono in/Mono out 1 (Mode=1), Mono in/Mono out 3 (Mode=2), Mono in/Stereo out 1 (Mode=3)

This models an analog delay that lets you add a vibrato effect to the delayed sound. The actual unit provided 400 ms of delay time, but this simulation extends this up to 1400 ms while maintaining the same warm sound, and can also be used as a sub-delay for the DELAY section.



### SPEED

Adjusts the modulation speed.

[0.100...10.00 Hz]

### DEPTH

Adjusts the modulation depth.

[0.0...10.0]

### FEEDBACK

Adjusts the amount of feedback.

[0.0...10.0]

### TIME

Specifies the delay time.

[1.0...10.0]

### MODE

Selects the output method.

[1, 2, 3]

1: Mono output.

2: Stereo mode with the effect sound from the right and dry sound from the left.

3: Reverse-phase stereo mode with dry + effect in the left side and dry — effect in the right side.

### MIX

Adjusts the mix amount of the effect.

[0.0...10.0]

## 12. TALK MOD

This is an envelope controlled talking modulator. The vocal character will change according to the input from your guitar.



### ATTACK

Adjusts the speed of the response.

[1.0...10.0]

### DEPTH

Adjusts the depth of operation.

[0.0...10.0]

### TYPE

Selects one of the following transitions between vowels.

'A'-'E', 'A'-'Y', 'A'-'O', 'A'-'U', 'E'-'Y', 'E'-'O', 'E'-'U', 'Y'-'O', 'Y'-'U', 'O'-'U'

[A-E...O-U]

### MANUAL

Adjusts the vocal character. "MANUAL" has no effect if "DEPTH" is set to 10.0.

[1.0...10.0]

### POLARITY

Specifies the direction of change.

[UP, DOWN]

### SENS

Adjusts the sensitivity of response to the guitar volume.

[0.0...10.0]

**NOTE:** If you set "DEPTH" to 0.0 and assign "MANUAL" to an optional Korg EXP-2 foot controller connected to the JamVOX monitor, you can use the foot controller to control the vowel. (See JamVOX owner's manual "Option pedal/switch settings" on page 32)

## F. Delay Effects

Here you can make settings for a delay effect. You can choose one of eleven types.

Parameters marked with  can be controlled by an optional Korg EXP-2 foot controller connected to the JamVOX monitor.

Parameters marked with  can be controlled by an optional VOX VFS-2 foot switch connected to the JamVOX monitor.

For details on how to assign a parameter to the foot controller or foot switch, refer to “Option pedal/switch settings” (see JamVOX owner’s manual p. 32).

### 1. STEREO DELAY

Stereo in/Stereo out 1

This is Korg’s 24-bit digital delay, the DL8000R. With the exception of the sampling frequency and wave control of the DELAY TIME, the circuit is essentially identical. Since this is a full-stereo design, it’s particularly effective to place it after the output of a stereo MOD or REVERB effect.



#### TIME

Sets the delay time.

[1...4000 ms]

#### FEEDBACK

Adjusts the amount of feedback.

[0.0...10.0]

#### TONE

Adjusts the tone of the delay.

[1.0...10.0]

#### DUCKING

Adjusts the sensitivity at which the effect will “duck” (decrease) in response to the volume of your guitar.

**Ducking:** This automatically lowers the volume of the delay sound when you play your guitar loudly, allowing your playing to come through.

[0.0...10.0]

#### MIX

Adjusts the mix amount of the delay.

[0.0...10.0]

## 2. CROSS DELAY

Stereo in/Stereo out 3

This is the DL8000R with settings to make the feedback cross over from L→R and R→L.



### TIME

Sets the delay time.

[1...4000 ms]

### FEEDBACK

Adjusts the amount of feedback.

[0.0...10.0]

### tone

Adjusts the tone of the delay.

[1.0...10.0]

### DUCKING

Adjusts the sensitivity at which the effect will “duck” (decrease) in response to the volume of your guitar.

[0.0...10.0]

### MIX

Adjusts the mix amount of the delay.





[0.0...10.0]

### 3. 2TAP DELAY

Mono in/Stereo out 1

This is the DL8000R with two delay taps whose DELAY TIME is skewed and separately assigned to L and R, turning a mono input into stereo.







<b>TIME</b>		[1...4000 ms]
Sets the delay time.		
<b>FEEDBACK</b> 		[0.0...10.0]
Adjusts the amount of feedback.		
<b>TONE</b> 		[1.0...10.0]
Adjusts the tone of the delay.		
<b>DUCKING</b> 		[0.0...10.0]
Adjusts the sensitivity at which the effect will “duck” (decrease) in response to the volume of your guitar.		
<b>TAP TIME</b>		[0.0...10.0]
Adjusts the ratio of delay time of the right relative to the left.		
<b>MIX</b> 		[0.0...10.0]
Adjusts the mix amount of the delay.		

## 4. RHYTHM DELAY

Mono in/Mono out 1

This provides a DL8000R function in which the “TIME” of two delay taps is automatically set according to the “RHYTHM” you specify.



<b>TIME</b>		[1...4000 ms]
Sets the delay time.		
<b>FEEDBACK</b> 		[0.0...10.0]
Adjusts the amount of feedback.		
<b>TONE</b> 		[1.0...10.0]
Adjusts the tone of the delay.		
<b>DUCKING</b> 		[0.0...10.0]
Adjusts the sensitivity at which the effect will “duck” (decrease) in response to the volume of your guitar.		
<b>RHYTHM</b>		[1...11]
Specifies the two-tap rhythm delay when the delay time is set to quarter-note timing. For some settings, only one tap is used.		
<b>MIX</b> 		[0.0...10.0]
Adjusts the mix amount of the delay.		



## 5. HOLD DELAY

Mono in/Mono out 1

This models a Korg DL8000R 24-bit digital delay set to the “hold delay” setting.



### TIME

Sets the delay time.

[1...8000 ms]

### FEEDBACK

Adjusts the amount of feedback.

[0.0...10.0]

### TONE

Adjusts the tone of the delay.

[1.0...10.0]

### MIX

Adjusts the mix amount of the delay.

[0.0...10.0]

### HOLD SW

If this is ON, the delay sound will be held.

[OFF, ON]

**NOTE:** If you select HOLD DELAY as the delay effect, HOLD DELAY (HOLD) will automatically be assigned to the optional VOX VFS-2 foot switch connected to the JamVOX monitor. Pressing the foot switch will hold the delay sound.

## 6. REVERSE DELAY

Mono in/Mono out 1

This is a digital delay that plays the delay sound backward. You can get some really cool results by playing long notes in a legato fashion.



### TIME

Sets the delay time.

[26...8000 ms]

### FEEDBACK

Adjusts the amount of feedback.

[0.0...10.0]

### tone

Adjusts the tone of the delay.

[1.0...10.0]

### MIX

Adjusts the mix balance between the delay sound and direct sound. With a setting of 10.0 you will hear only the delay.





[0.0...10.0]

## 7. MOD DELAY

Mono in/Mono out 1

This models Korg's first digital delay, the SDD-3000. You can also use this to produce chorus or flanger-like effects by setting a short "TIME" and using the LFO to modulate it.



<b>TIME</b> 	[3...2000 ms]
Sets the delay time.	
<b>FEEDBACK</b> 	[0.0...10.0]
Adjusts the amount of feedback.	
<b>TONE</b> 	[1.0...10.0]
Adjusts the tone of the delay.	
<b>SPEED</b> 	[0.100...10.00 Hz]
Adjusts the modulation speed.	
<b>MIX</b> 	[0.0...10.0]
Adjusts the mix amount of the delay.	

## 8. SWEEP DELAY

Mono in/Mono out 1

This also models the SDD-3000. Here you can use the envelope of your guitar signal to control the DELAY TIME, and by setting a short "TIME" and raising the "FEEDBACK" you can produce a distinctive flanger effect. Even with conventional settings of "TIME," you can produce unique effects that would not be possible with an LFO.



### TIME

Sets the delay time.

[26...2000 ms]

### FEEDBACK

Adjusts the amount of feedback.

[0.0...10.0]

### STONE

Adjusts the tone of the delay.

[1.0...10.0]

### SENS

Adjusts the sensitivity at which the effect responds to the volume of your guitar.

[0.0...10.0]

### MIX

Adjusts the mix amount of the delay.

[0.0...10.0]

## 9. ANALOG DELAY

Mono in/Mono out 1

This models an analog delay that used a bucket-brigade device (BBD) instead of a tape mechanism and was known for its compactness and reliability. It is characterized by a warmly distorted sound.



### TIME

Sets the delay time.

[1...2000 ms]

### FEEDBACK

Adjusts the amount of feedback.

[0.0...10.0]

### STONE

Adjusts the tone of the delay.

[1.0...10.0]

### MIX

Adjusts the mix amount of the delay.

[0.0...10.0]

## 10. MULTI HEAD

This is a model of a tape echo unit boasting three playback heads. The echo from each head has its own feedback loop, letting you create warm and complex “multi-tap” echo effects.



### TIME

Sets the delay time.

[1...2000 ms]

### FEEDBACK

Adjusts the amount of feedback.

[0.0...10.0]

### tone

Adjusts the tone of the delay sound.

[1.0...10.0]

### MODE

Specifies the combination of heads that will be used.

[1, 2, 3, 4, 5]

1: Conventional echo.

2:  The delayed sound produces a rhythm of “ta-ta-ta (rest).”

3:  The delayed sound produces a rhythm of “ta (rest) ta-ta.”

4:  The delayed sound produces a rhythm of “ta-ta (rest) ta.”

5:  The delayed sound produces a rhythm of “ta-ta-ta-ta.”

### MIX

Adjusts the mix amount of the delay.

[0.0...10.0]

## 11. ECHO PLUS

Mono in/Mono out 1

This models one of the most respected analogue tape echo machines ever made. In the original, the “echo” is produced by a playback head and the exact “delay time” is set by varying the motor speed. Many professionals prefer these “lo-fi” units because of the warm, dark echoes they produce.



### TIME

Sets the delay time.

[26...2000 ms]

### FEEDBACK

Adjusts the amount of feedback.

[0.0...10.0]

### TONE

Adjusts the tone of the delay.

[1.0...10.0]

### LO DAMP

Adjusts the amount of low-frequency attenuation.

[0.0...10.0]

### MIX

Adjusts the mix amount of the delay.

[0.0...10.0]

## G. Reverb Effects

Here you can make settings for the reverb effect. You can choose one of twelve types.

Parameters marked with  can be controlled by an optional Korg EXP-2 foot controller connected to the JamVOX monitor.

For details on how to assign a parameter to the foot controller or foot switch, refer to “Option pedal/switch settings” ( JamVOX owner’s manual p. 32).

### 1. SLAP

Mono in/Stereo out 1

This models a tiny room with a very short reverb time.



**TIME** 

Sets the reverb time.

[1.0...10.0]

**LO DAMP** 

Adjusts the attenuation of the low-frequency range.

[0.0...10.0]

**HI DAMP** 

Adjusts the attenuation of the high-frequency range.

[0.0...10.0]

**PRE DELAY**

Sets the initial delay before the reverberation begins. By adjusting this setting you can clarify the definition of the original sound.

[0...100 ms]

**MIX** 

Adjusts the mix amount of the reverb.

[0.0...10.0]



## 2. GATE

Mono in/Stereo out 1

This is a versatile gated reverb, ideal for percussive playing. By setting “SHAPE” to 2 and “MIX” to 10.0 (i.e., effect only) you can create a reverse-playback type of sound.



### TIME

Sets the gate time.

[5...500 ms]

### LO DAMP

Adjusts the attenuation of the low frequency range.

[0.0...10.0]

### HI DAMP

Adjusts the attenuation of the high frequency range.

[0.0...10.0]

### PRE DELAY

Sets the initial delay before the reverberation begins.

[0...100 ms]

### SHAPE

Sets the type of gate.

1: Conventional gate.

2: Reverse-playback type gate.

[1, 2]

### MIX

Adjusts the mix balance between the reverb sound and direct sound. With a setting of 10.0 you will hear only the reverb sound.

[0.0...10.0]

### 3. SPRING

Mono in/Stereo out 1

This models the spring reverb system used in guitar amps — ideal for surf music! The parameters are same as in SLAP. (See “SLAP” on page 48)

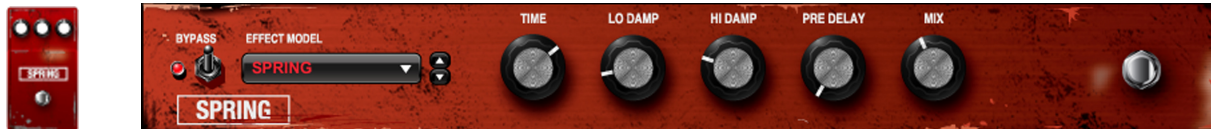

### 4. BOUNCE

Mono in/Stereo out 1

This models a spring reverb that produces a higher-density reverberation. The parameters are same as in SLAP. (See “SLAP” on page 48)



### 5. PLATE

Mono in/Stereo out 1

This models a type of reverb unit that works by vibrating a metal plate instead of a spring. It is adjusted to a fairly short reverb time. This reverberation is characterized by a rapid attack, and is suitable for percussive playing. The parameters are same as in SLAP. (See “SLAP” on page 48)



## 6. GARAGE

This models a garage that produces a high-density reverberation. The parameters are same as in SLAP. (See “SLAP” on page 48)

Mono in/Stereo out 1

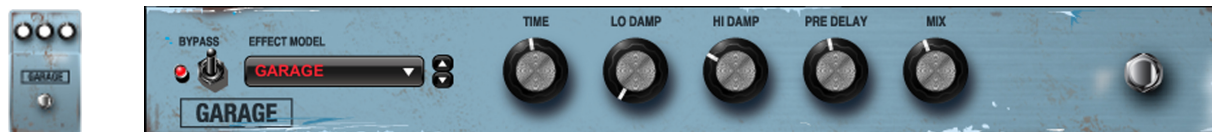

## 7. CHAMBER

In years past, recording studios often used a room (echo chamber) that was specially designed to produce reverberation and contained a speaker and mic used to record reverberation. This model simulates a mild-sounding echo chamber. The parameters are same as in SLAP. (See “SLAP” on page 48)

Mono in/Stereo out 1



## 8. CANYON

This models the reverberation of a canyon. The parameters are same as in SLAP. (See “SLAP” on page 48)

Mono in/Stereo out 1



## 9. ROOM

Mono in/Stereo out 1

This models the reverberation of a typical room, with numerous early reflections. The parameters are same as in SLAP. (See "SLAP" on page 48)



## 10. STUDIO

Mono in/Stereo out 1

This models the reverberation of a large room. The parameters are same as in SLAP. (See "SLAP" on page 48)

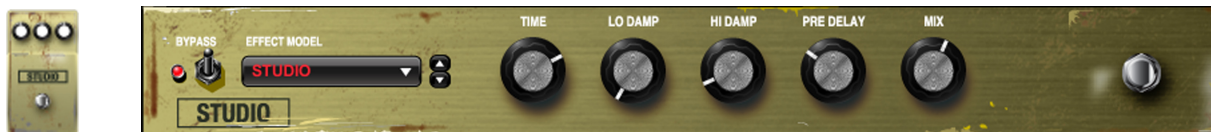

## 11. HALL

Mono in/Stereo out 1

This models the reverberation of a concert hall with numerous echoes. The parameters are same as in SLAP. (See "SLAP" on page 48)



## 12. ARENA

This models an arena with smooth and dense reverberation. The parameters are same as in SLAP. (See "SLAP" on page 48)

Mono in/Stereo out 1



### Block Diagram

For the modulation, delay, and reverb effects, the signal input/output configuration will be one of those shown in the block diagrams at right. The particular block diagram for each effect is listed at the right of the effect model name.

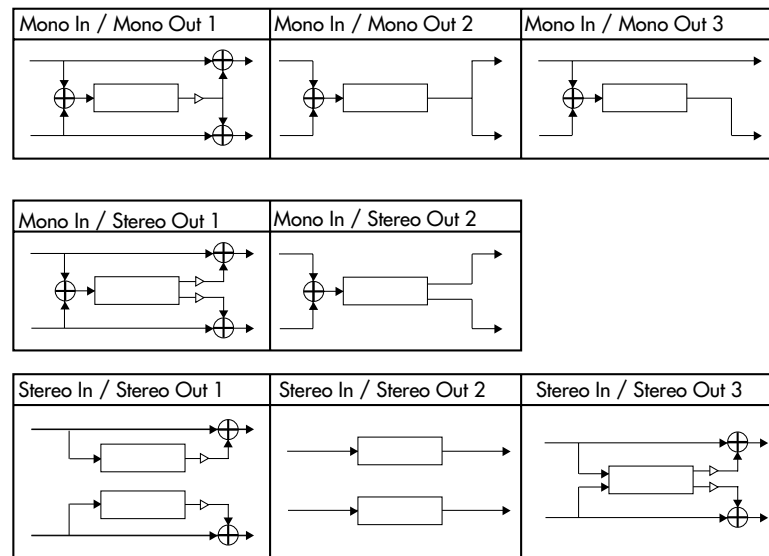



VOX AMPLIFICATION LTD. 9 Newmarket Court, Kingston, Milton Keynes, MK10 OAU, UK <http://www.voxamps.com/>