

PRX512Mi 12" 2-Way Multipurpose Self-Powered Sound Reinforcement System

Professional Series

Features:

- ▶ Dual angle enclosure for both front-of-house and floor monitor applications
- ▶ Eight M10 fly points for horizontal or vertical suspension. One M10 pull-back point.
- ▶ Optimized EQ for monitor or front-of-house applications
- ▶ JBL Differential Drive® woofer
- ▶ 1.5" annular polymer diaphragm compression driver
- ▶ Class-D, Crown® digital amplifier.
- ▶ DSP input section, crossover, dynamic limiting, component optimization, selectable system EQ
- ▶ Professional XLR line and ¼" Mic/Instrument inputs, with loop through.
- ▶ Illuminated logo for clear Power-On status
- ▶ Dual angle pole mount socket
- ▶ DuraFlex™ coated plywood construction

Application:

PRX512Mi is the most compact and versatile speaker in the PRX500 Series. It has been designed to deliver the most performance for its weight and size as both a stage monitor and a front of house main PA. Two user selectable EQ settings are provided to optimize the system for either application. With a dual socket pole mount the PRX512Mi is a perfect match with a PRX518S subwoofer, offering a high performance self-powered sub/sat system.

The PRX512Mi is a self-powered, lightweight two-way multipurpose loudspeaker system. The PRX512Mi is comprised of a 262F 305 mm (12") Differential Drive® woofer, a 2408H-1 37.5 mm (1.5 in) annular polymer diaphragm, neodymium compression driver mounted to a 70° by 70° horn, all driven by a multi-channel Crown International Class-D digital power amplifier. A proprietary DSP chip is at the core of a fully featured input section, providing user selectable system EQ, protection, input sensitivity selection, cross-over functionality, dynamic limiting and discrete component optimization.

The enclosure is constructed of quality plywood and coated in JBL's rugged DuraFlex™ finish. An integrated dual angle pole mount on the bottom enables easy deployment and aiming. The eight integrated M10 flying points and pull-back point provide suspension options. The CNC-machined steel grille wraps around the sides of the enclosure so there are no protruding lips on the front of the box to create acoustical interference. The grille is also lined with an acoustically transparent foam to provide additional driver protection.

The amplifier input panel offers XLR or ¼ inch jack compatibility and a sensitivity switch provides extra flexibility, making it possible to connect literally any sound source without using a mixer. Signal present and overload lights indicate the system status and assist in setting the optimum level, via the level control knob.



Preliminary Specifications:

System Type:	Self powered 12", two-way, bass-reflex,
Frequency Range (-10 dB):	46 Hz – 20 kHz (EQ in main position) 60 Hz – 20 kHz (EQ in monitor position)
Frequency Response (±3 dB):	76 Hz – 20 kHz (EQ in main position) 90 Hz – 20 kHz (EQ in monitor position)
Coverage Pattern:	70° x 70° nominal
Directivity Index (DI):	10.2 dB
Directivity Factor (Q):	10.8
Crossover Modes:	DSP controlled 48 dB/Oct. filter slope
Crossover Frequency:	1.6 kHz
System Power Rating	500 W continuous, 1000 W peak
LF Power amp	Class-D, 400 Watt (continuous) at driver impedance
HF Power amp	Class-D, 100 Watt (continuous) at driver impedance
Distortion:	Less than 0.1% at rated power
Maximum Peak Output:	133 dB SPL
Signal indicators:	Overload: Red LED indicates input overload condition Signal: Green LED indicates signal presents
Input sensitivity:	Mic position: -25 dBu to 0 dBu Line position: +28 dBu to +10 dBu
Input Impedance:	64 K Ohms (balanced), 32 K Ohms (unbalanced)
EQ:	Presets for Main and Monitor position
LF Driver:	1 x JBL 262F 380 mm (12 in) Differential Drive® woofer
HF Driver:	1 x JBL 2408H-1 37.5 mm (1.5 in) annular polymer diaphragm, neodymium compression driver
Enclosure:	Trapezoidal, 18 mm, plywood
Suspension / Mounting:	Dual 36 mm pole socket, eight M10 suspension points and one M10 pull-back point.
Transport:	Integrated handle with backing cup
Finish:	Anthracite DuraFlex™ finish
Grille:	Powder coated, Anthracite black, 18 gauge perforated steel with acoustically transparent black foam backing.
Input Connectors:	Balanced XLR / ¼ inch combo jack with XLR loop through,
Dimensions (H x W x D):	650 mm x 380 mm x 350 mm (25.5 in x 15 in x 14 in)
Net Weight:	18 kg (40 lb)

JBL continually engages in research related to product improvement. Some materials, production methods and design refinements are introduced into existing products without notice as a routine expression of that philosophy. For this reason, any current JBL product may differ in some respect from its published description, but will always equal or exceed the original design specifications unless otherwise stated.

▶ PRX512Mi 12" 2-way Multipurpose Self-powered Sound Reinforcement System

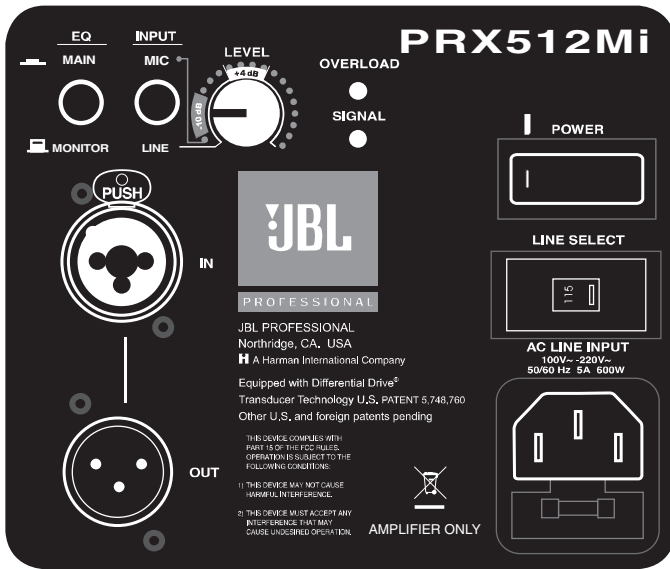

Frequency Response

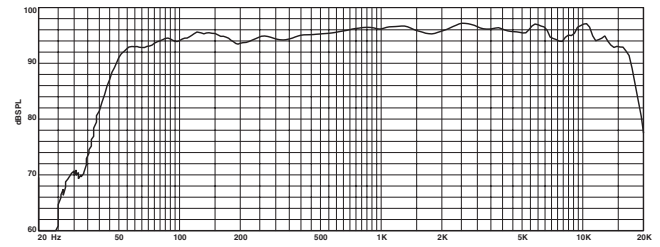

PRX512Mi Input Panel

Block Diagram

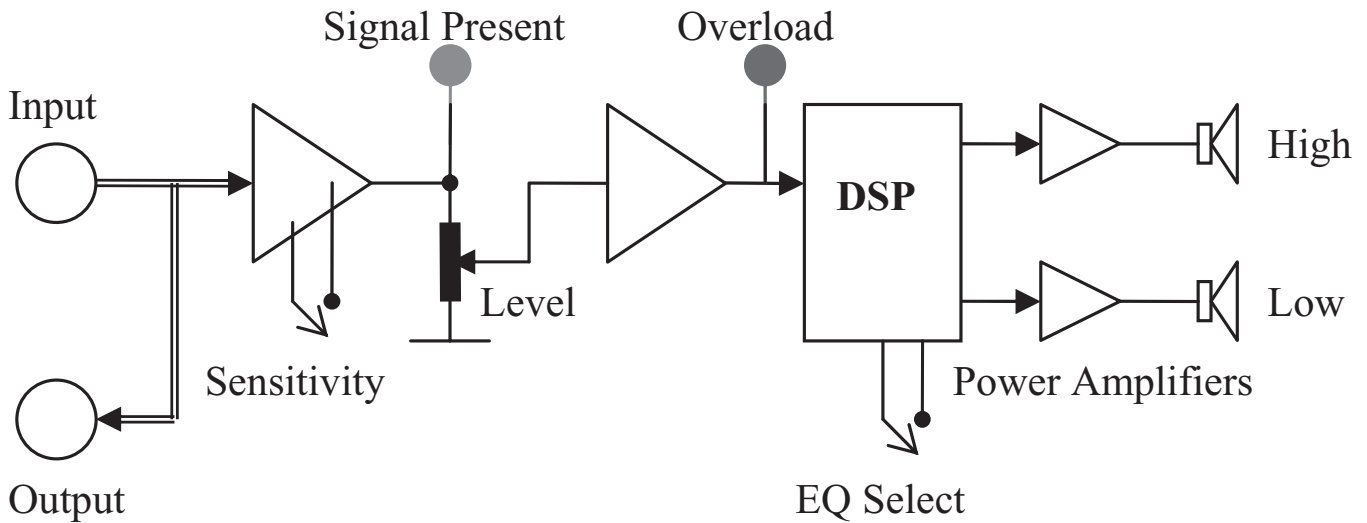

JBL Professional
8500 Balboa Boulevard, P.O. Box 2200
Northridge, California 91329 U.S.A.

A Harman International Company
© Copyright 2009 JBL Professional
www.jblpro.com

SS PRX512Mi
CRP
03/09