



J33

Phono Preamp DI

User Guide

Radial Engineering
1638 Kebet Way, Port Coquitlam BC V3C 5W9
Tel: 604-942-1001 Fax: 604-942-1010
email: info@radialeng.com

Radial Engineering is a division of C•TEC (JP CableTek Electronics Ltd.)

www.radialeng.com

Radial J33 Phono Preamp DI Users Guide

Table of Contents	Page
Introduction	2
Feature Set	3
Input panel	4
Output panel	5
Making Connections	6
FAQ	7
Specifications	9
Warranty	Back cover

WELCOME

Congratulations on your purchase of the Radial J33 combination phono preamp and turntable direct box. This handy device has been developed to interface a conventional turntable with magnetic cartridge to a recording, hi-fi or PA system using the XLR microphone input on a mixer or preamp.

As with all Radial products, every attempt has been made to make using the J33 'plug & play' easy-to-use. However, please read this manual thoroughly to ensure the best possible results.

Should you have any questions on your new J33, please consult the Radial website FAQ section as this is where we publish answers from users after a product has been released. If you do not find the answer you are looking for on-line, please feel free to send us an email at info@radialeng.com and we will do our very best to get back to you promptly.

Now dust off that old Perry Como Christmas record, pour yourself some eggnog and enjoy!

www.radialeng.com

Radial is a division of JP Cabletek Electronics Ltd.
Specifications and appearance subject to change without notice.
Radial J33 manual V1.0 - Part #: R870-1090-00

INTRODUCTION

Since the advent of the compact disc, the use of long-playing records has become so sparse that it has become difficult to find a hi-fi receiver that is equipped with a phono input. With literally millions of albums floating around the world, a need has emerged to capture these recordings and transfer them to today's digital formats.

The Radial J33 provides a solution with a simple device that is 'plug & play' easy-to-use and built to Radial's professional standards for sound quality and durability. Equipped with an RIAA preamp and choice of -10dB consumer line-level and pro 600-Ohm mic-level outputs, the J33 is right at home in the studio, on the stage and in the DJ booth.

For the enterprising studio, this opens the door to a new business opportunity: a phono to CD transfer service that will allow families to enjoy their favorite CD's in their cars and on their new surround sound systems. The Radial J33 also boasts other advantages: for the broadcast station and museum, old record collections can now be easily archived by transferring old phono recordings to digital media. With the plethora of digital 'noise-eliminating' software, less than ideal recordings can now be updated to approach today's signal-to-noise expectations.

For the recording studio, the emergence of 'scratching' in hip-hop, rap and pop music opens the door to better recordings and more creativity by allowing a turntable to connect through high-end processing, opening up opportunities for re-recording and greater artistic freedom.

RIAA PREAMP

The Radial J33 is a combination RIAA phono preamp and active direct box that allows you to connect a conventional turntable with magnetic cartridge to a recording system, hi-fi or PA system.

An RIAA phono preamp is a device that boosts the signal from a turntable and applies a pre-defined equalization curve. The RIAA equalization curve is applied as pre-emphasis EQ during the cutting of the metal master, and as a de-emphasis EQ on playback. In other words, a record is cut with the low frequencies reduced and the high frequencies boosted (pre-emphasis), and on playback the opposite occurs (de-emphasis). The RIAA preamp in the J33 provides this required de-emphasis EQ.

The result is a flat frequency response, but with noise such as hiss and clicks arising from the surface of the record itself reduced (or "attenuated"). The other main benefit of the RIAA system is longer playback times. The RIAA equalization curve has operated as a global industry standard for the recording and playback of vinyl records since 1954.

RIAA RESPONSE CURVE

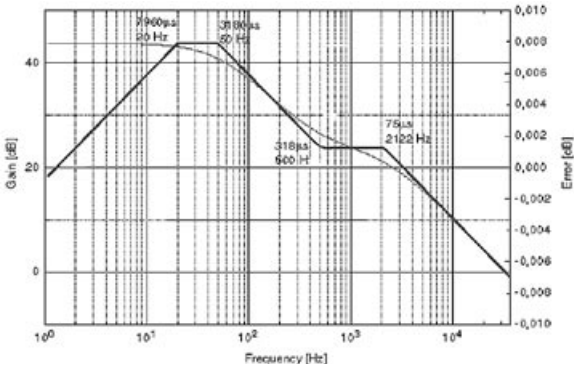

FEATURE SET

The J33 features a pair of stereo inputs for the turntable. A ground lug is provided to properly ground the turntable to avoid system noise. This signal then feeds the RIAA preamp that boosts the phono signal while introducing the RIAA equalization curve.

Next to the turntable inputs are a series of unbalanced -10dB consumer line-level outputs. These include a stereo set of RCA connectors that can connect to the auxiliary or CD inputs on a typical hi-fi receiver; a 1/8" (3.5mm) stereo mini-jack that can connect to an MP3 player or computer sound card and a 1/4" TRS connector for a stereo feed that can be split using an insert cable to a pair of line inputs on a PA or DJ mixer.

The J33 is also equipped with a low-frequency rumble filter. This gently rolls off the bass at 200Hz and is -3dB at 100Hz to reduce the low frequency rumble and feedback that can often occur when spinning records in high volume environments such as on stage or in nightclubs.

To connect to professional balanced systems, the Radial J33 is equipped with a pair of male XLR connectors. The active balanced drivers, shown in the block diagram, convert the signal to a low impedance (600ohm), microphone level, stereo signal. The J33's balanced XLR outputs can drive turntable signals well over 100 meters (328 feet) without appreciable loss or noise. This makes the J33 ideal for driving turntable signals through a snake system on stage and through the patch bays and complex wiring systems that abound in the professional studio.

The Radial J33 may be powered with 48V phantom or with the included 15VDC power supply. The J33 will automatically select the power source and the two LED on the front panel will illuminate, indicating power is present.

INPUT PANEL FEATURES



1. LED power indicator

For left and right channels. Lights when the 15VDC power supply is connected or when phantom power is applied from a mixing console.

2. Rumble filter

Applies a high pass filter when pushed in.

3. Gound lug

Attatch the turntable ground lug here.

4. 3.5mm stereo output (thru-put)

Paralleled stereo output for direct connection to computer sound cards, laptops or any device with a 3.5mm input.

5. 1/4" phono stereo output (thru-put)

Paralleled stereo output for direct connection to a local mixer, recorder or any device with a 1/4" TRS input.

6. RCA stereo output (thru-put)

Paralleled stereo outputs for direct connection to a local mixer, recorder or any device with a RCA input.

7. RCA stereo input

Stereo input connectors for turntable signals. Use in conjunction with the ground lug.

OUTPUT PANEL FEATURES

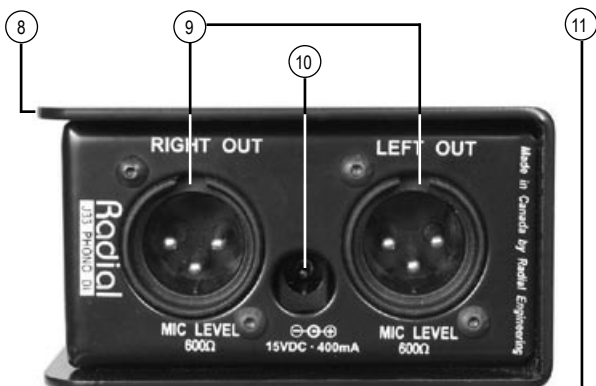

8. Bookend design

14 gauge steel outer shell creates protected zone around connectors and switches and wraps around a welded case with I-beam construction for maximum durability. Finished in tough baked enamel.

9. Left and right XLR outputs

Balanced and low impedance (600Ω) microphone level output. Connect to sound system inputs or main mixing console.

10. 15V DC power supply connection

The 15VDC supply is connected here for powering the J33. There is no power switch and leaving the J33 on will not harm it. Not used if J33 is powered through phantom power from a mixing console.

11. Full-bottom no-slip pad

This provides electrical isolation and plenty of "stay-put" friction to keep the J33 in one place.

MAKING CONNECTIONS

Using the Radial J33 is easy. Before connecting, start by making sure all volume levels are set to zero and the audio system is turned off. This will avoid any loud pops in your sound system that could cause system damage.

Begin by connecting the turntable outputs to the J33 using the RCA connectors and securing the ground lead from the turntable to the ground lug on the J33.

If you are planning to connect the J33 without a mixing console connected to the XLR outputs, you will need to use the external 15v DC power supply. If you plan to connect the J33 using the XLR outputs to a mixing console, it will likely be equipped with 48v DC phantom power to supply the J33. Performance is identical with either form of power supply and the J33 will automatically select the power source depending on how you have it set up. As soon as you connect the J33's 15v DC power supply or turn on the phantom power, the J33's front panel LED indicators will light up to indicate power is present.

Make the connections from the J33 to whichever piece of gear you would like. The unbalanced -10dB outputs are commonly known as consumer line-level outputs. These will drive inputs found on hi-fi equipment and the unbalanced line-level inputs found on mixing consoles. The balanced XLR outputs on the J33's rear panel are mic-level so that they will match up with other direct boxes and microphones, thus enabling the J33 to be used along with microphones in snake systems, mic splitters and through console mic preamps.

You can use any or all the output connectors at once, enabling you to, for instance, connect your turntable to the J33, the -10dB RCA line-level outs to a DJ mixer and the balanced XLR outs to a PA system, all at the same time. Depending on how the equipment is connected to the AC mains, there can be a potential for ground loop hum when using both the balanced and unbalanced outputs at the same time. If a ground loop hum develops, the solution is to lift the ground at the PA mixer and use the J33's included power supply.

Once your connections are made, turn on the sound system. Begin at low volume to make sure the sound system is working properly, get your favorite album and listen. The sound should be clear. If you hear any hum or buzz, check the ground wire, as this is the usual culprit. It should be firmly held by the J33's ground lug. If you are driving your system at high volume levels and begin to hear low frequency resonance, try depressing the rumble filter. This will usually tame low frequency PA system feedback.

You are now ready to spin away! Have fun!

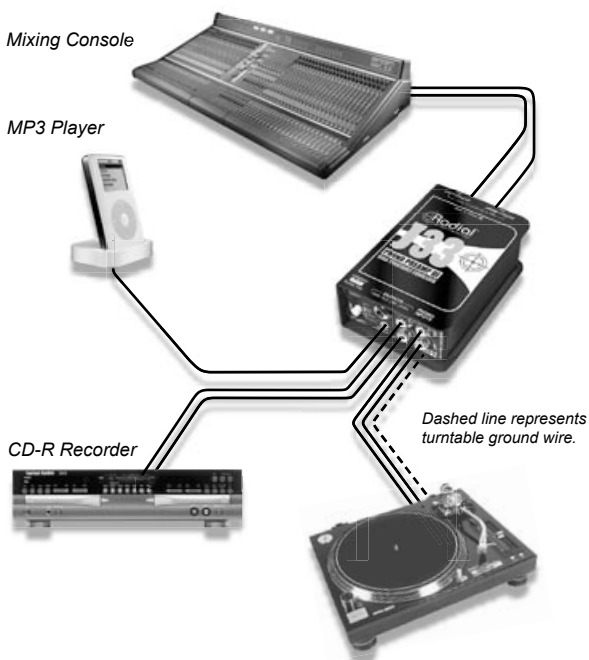

FAQ

What is an RIAA pre-amp and why do I need one with a turntable?

Because when the album was produced, a preset EQ curve was introduced so that on playback you would get better sound. Keep in mind that when stereo long-play records first appeared some 60 years ago, the transfer was vibration caused by minute bumps inside the groove. The needle captures these and converts them to an electrical impulse. This system evolved to where the quality was surprisingly high. Part of the magic to the system's performance was the RIAA curve that enables the system to produce a musically balanced reproduction of the original recording.

Can I use an active phono cartridge with the J33?

No. The J33 is designed to use magnetic cartridges which make up 99% of all turntable cartridges ever sold.

What should I do if I depress the rumble filter and still have feedback?

Try using an isolation pad such as the Primacoustic IsoPlane (www.primacoustic.com). This will reduce the vibration going into the turntable and help eliminate low frequency resonant feedback.

Can I use the Radial J33 for other devices such as keyboards or computer sound cards?

No. The J33's input is pre-equalized with the RIAA curve. This curve would make any other source sound bad, plus these line-level devices would overload the J33's sensitive input circuit and cause distortion.

Why is there no ground lift on the J33?

Because the ground lift would disconnect the pin-1 on the XLR which in turn would shut off the phantom power.

Can I rackmount the J33?

Yes. The Radial J-Rak will allow as many as 8 direct boxes to be rack-mounted in two RUs. Go to the Radial website for more details on the J-Rak. (www.radialeng.com)

What should I do if the LEDs do not light up?

Check that the external power supply is connected or, if connecting to a mixer through the J33's XLR outputs, make sure the phantom power has been turned on at the mixer.

Can I record an album directly to my computer sound card using the J33?

Yes. Most sound cards are equipped with a 3.5mm input connector. Connect the line-level output of the J33 to the computer and you should be set to go. Sound card input levels vary, so watch for distortion as the output of the J33 is quite hot. Your computer sound card software should allow you to pad down the input should this be a mic-level input.

How will the J33 sound with my hi-fi system?

Great! The J33 is a low noise preamplifier and will out-perform the typical RIAA preamp built into consumer hi-fi equipment.

J33 BLOCK DIAGRAM

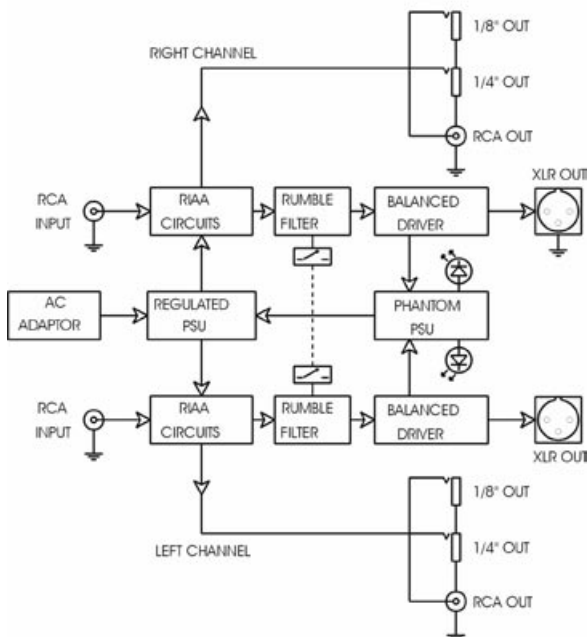

J33 Specifications <i>(subject to change without notice)</i>	
Freq. Response (RIAA curve)	+19.15dB @ 20Hz to -19.65dB @ 20kHz (Ref: 0dB @ 1 KHz)
Total harmonic distortion	0.005 % @ 1 KHz
RIAA deviation	+/- .5dB maximum
Max. phono input level	50mV @ 1 KHz
High pass filter	200Hz cut off, -3dB at 100Hz
Unbalanced outputs	10kOhm, -10dB line-level
Balanced outputs	600 ohms, -60dB mic-level, pin 2 hot
Power (auto-switching)	15v DC or 48v phantom
Size (W x D x H)	3.25"x 5"x1.75" (83x126x45mm)
Weight	1.5 lbs. (.7 kg)
Warranty:	3 Years

RADIAL ENGINEERING 3 YEAR LIMITED WARRANTY

RADIAL ENGINEERING (a division of J.P Cabletek Electronics Ltd.) "Radial" warrants this product to be free from defects in material and workmanship to the original owner and will remedy any such defects free of charge according to the terms of this warranty.

Radial will repair or replace (at its option) any defective component(s) of this product (excluding batteries, finish and wear and tear on components under normal use) for a period of three (3) years from the original date of purchase. In the event that a particular product is no longer available, Radial reserves the right to replace the product with a similar product of equal or greater value.

To make a request or claim under this limited warranty, the product must be returned prepaid in the original shipping container (or equivalent) to Radial or to an authorized Radial repair center and you must assume the risk of loss or damage. A copy of the original invoice showing date of purchase and the dealer name must accompany any request for work to be performed under this limited warranty. This limited warranty shall not apply if the product has been damaged due to abuse, misuse, misapplication, accident or as a result of service or modification by any other than an authorized Radial repair center.

THERE ARE NO EXPRESSED WARRANTIES OTHER THAN THOSE ON THE FACE HEREOF AND DESCRIBED ABOVE. NO WARRANTIES WHETHER EXPRESSED OR IMPLIED, INCLUDING BUT NOT LIMITED TO, ANY IMPLIED WARRANTIES OF MERCHANTABILITY OR FITNESS FOR A PARTICULAR PURPOSE SHALL EXTEND BEYOND THE RESPECTIVE WARRANTY PERIOD DESCRIBED ABOVE OF THREE YEARS. RADIAL SHALL NOT BE RESPONSIBLE OR LIABLE FOR ANY SPECIAL OR INCIDENTAL OR CONSEQUENTIAL DAMAGES OF LOSS ARISING FROM THE USE OF THIS PRODUCT. THIS WARRANTY GIVES YOU SPECIFIC LEGAL RIGHTS, AND YOU MAY ALSO HAVE OTHER RIGHTS, WHICH MAY VARY, FROM STATE TO STATE (OR PROVINCE TO PROVINCE).



True to the Music

1638 Kebet Way, Port Coquitlam BC V3C 5W9
tel: 604-942-1001 fax: 604-942-1010 email:
info@radialeng.com

www.radialeng.com

Radial J33 users guide V1.0 - Part #: R870 1090 00