

HOW TO

CAPTURE YOUR ART!



AN INTRODUCTION
TO MULTITRACK
RECORDING FROM

TASCAM[®]

Capturing your art: How to develop your music by recording it.

It comes down to one simple, unavoidable fact: Every note you play that's not recorded is lost forever. Whether it's a new song idea, a hot riff or just a phrase that you need to practice over and over, record it and it's yours. To hear again. To share. To develop. To improve on. All it takes to capture your art is a multitrack recorder from TASCAM.

Getting started in the world of multitrack recording.

Have you seen all the great recording equipment available today? Maybe you've read about it in music magazines, heard about it on the Internet, or have a friend who's gotten some equipment. No matter what kind of music you make, this gear

can help you write better songs and make better music. Even if you're not aiming for stardom, multitrack recording can be a lot of fun.

But for a lot of us it just seems too complicated. There are so many different choices available, you can't figure out what's right for you. When you ask questions, all you get are buzzwords.

If the world of multitrack recording makes you feel like you've just walked into a private club where everyone else speaks Geek, this guide is for you. It explains, in plain English, the basics of multitrack recording and what you can expect from the different kinds of gear available. It assumes you have no prior experience with recording. We know what it's like because TASCAM has introduced hundreds of thousands of people to the world of multitrack recording over the last thirty years. And you could be next.

First of all, don't feel like you're the only one who has questions. Even for people with recording experience, the field has grown so huge so fast that no one can keep up with every new development. But

like learning how to use a new cell phone, what seems baffling at first will become second nature after a little bit of reading and trying it out.

Develop your skills by recording your own music.

Forget all the jargon and technology for a minute and remember why this technology was invented in the first place.

Music is made up of many parts. Multitrack technology simply allows you to separate the parts and develop each one, making a good recording better. This technology can help you grow as a musician and/or writer—and you don't have to be a tech-head to do it.

With your own multitrack recording equipment, you can hear how you sound without the pressure of anyone else listening. By experimenting with different styles and sounds in the privacy of your own studio, you'll become your own best critic. You can push yourself to the limits of your ability, keeping what works and erasing the parts that, umm, aren't so hot. If you're a writer, you can record an interesting but



incomplete song element, and play around with it until you come up with the magical combination of the other parts or lyrics that make a great song. That's what it's all about.

Need help putting your lyrics to music?

If you're a singer or lyric writer without a band, take heart. Today's tools have become so advanced and easy to use that they're practically like having a songwriting partner. You can start simply, and work your way up in technical and musical skill, as far as your dedication will take you.

A lot of great musicians and songwriters have been using these tools since they were introduced, and agree that recording helped them to become better artists without getting mired down in technology. So, don't be afraid. You have nothing to lose.

OK, now down to the nuts and bolts.

Tracking, overdubbing, and mixdown.

Multitrack recording is a great tool for any musician or songwriter because it lets you build up a musical piece one part at a time, without having to organize a band or having to play and sing parts simultaneously.

Let's start with a 4-track example. We're going to represent the four tracks like this:

TRACK 1
TRACK 2
TRACK 3
TRACK 4

Let's say you're playing guitar when an idea for a new pattern of chords comes up. You simply plug your guitar into Track 1, hit record, and play the pattern for a few minutes (represented by the notes in track 1 of the drawing below). This is called *laying the basic track*.

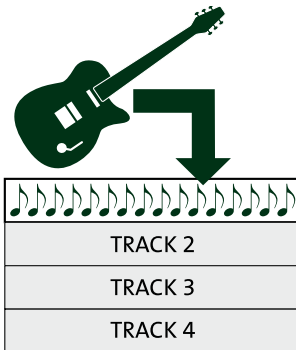

Because the TASCAM recorders we're talking about here are multi-tracks, not just stereo recorders, you can now rewind to the beginning, plug a microphone into Track 2, and sing along with the guitar you just recorded.

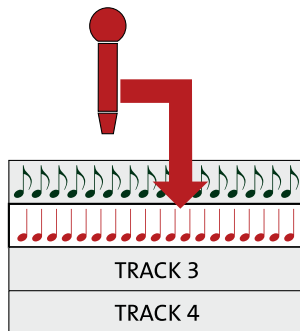

Rewind again, and you can record a lead guitar part on Track 3.

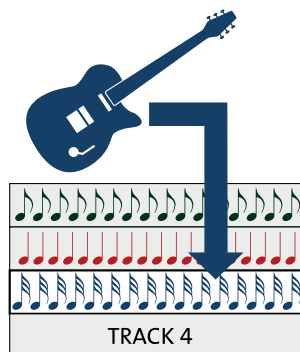

- Simple 4-track cassette recorder
- One 1/4" jack mic / line input for vocals and instruments
- Four track level, four pan and one master level control
- Master fader with 4-LED level display
- Headphone output

PORTA02 mkII



- 4-track cassette recorder with 2-track simultaneous recording
- Two 1/4" jack mic / line inputs for vocals and instruments; Hi-Z guitar input (assignable to both mic/line inputs)
- Easy-to-use 4-channel mixer section with pan and level controls for mixing down
- Headphone output with separate level control
- Dual faders with four-LED level meters

This *overdubbing* capability lets you change or add any track at any time, without affecting the others.

You can't just give a multitrack tape or disk to someone to play back, however; you must first perform the last stage of the multitrack process, a *mixdown*. You use a mixer to adjust



the volume, EQ, effects, and stereo position of each track, producing a standard CD, DVD, or cassette for other people to listen to.



Differences in multitrack equipment.

No matter what equipment you buy, the basic process of tracking/overdubbing/mixdown is the same. The differences between equipment consist of:

- The number of tracks (4, 8, 16, or more)
- The *medium* that the tracks are recorded on (tape, hard disk, RAM, etc.)
- How flexible the mixer is (how many channels, what kind of EQ,

how many effect sends, what kind of inputs, and whether the mixer can be *automated*)

- What other equipment is included with the *workstation* such as *effect processors* that add reverb or special effects, synthesizers and drum machines, or even microphones
- Whether a stereo mixdown machine is included in the workstation (for example, some can make standard CDs or MP3s to be posted on a web site)
- Whether the system can be expanded for more tracks or channels or recording time, without switching to an entirely new system
- Whether it includes a *MIDI*

sequencer which can play synthesizers and drum machines in sync to the audio (these are called *virtual tracks*).

Don't worry if you don't completely understand these differences yet...it will become clear when we explain each product.

What route should you take?

TASCAM pioneered the concept of the personal project studio when it introduced the first affordable 4-track recorders in the 1970s. It now offers many different products designed to help you get started in

multitrack recording, depending on your needs:

- **Portastudios:** a 4-track analog cassette multitrack combined with a mixer (the features of TASCAM's various models are described in the colored boxes on page 3 and at right.)
- **Pocketstudio 5:** a self-contained recorder/arranger/mixer/effects device that records into digital memory (see page 7)
- **788:** a high-quality 8-track digital Portastudio with a digital mixer and effects (see page 9)
- Computer interfaces such as our **US-122, US-224, US-428** and software that turn your personal computer into a complete multitrack music production system (see pages 9 and 11).

We'll explain the advantages of each of these products, but the "right one" depends on your musical goals and how you like to work. In addition to finding out about the gear, you need to answer a few questions about yourself:

? **How musically advanced are you?** What kind of music will you be producing? Do you need a lot of tracks for overdubbing vocal and instrumental parts? Will you play the tracks yourself, or are you a vocalist singing over someone else's tracks?

What is the end product you want to make?

Rehearsal tapes? Demo CDs? Trading MP3s with friends on the Internet? A fully-produced CD for sale at gigs?

What's your attitude towards computers, and what computer

skills do you have? Do you have a computer or are you planning on getting one? What kind is it? What operating system does it use? Does it have USB ports or PCI slots? Are

you comfortable with computer operations, such as connecting hard disks and optimizing them? Is the world of cassette tape more your style, or are you somewhere in the middle?

As we noted, each of the TASCAM products mentioned is covered in the colored boxes on the right-hand pages of this booklet. For more information visit www.tascam.com or ask the dealer from whom you got this booklet.

text continues on next page ►



- 4-track simultaneous recording
- 8-input mixer section
- 2-band high/low equalizer on 4 main input channels
- Two dedicated 1/4" stereo inputs
- Two XLR balanced mic inputs assignable to Channels 1 through 4
- One 1/4" dedicated Guitar input
- RCA unbalanced stereo SUB inputs
- Separate main and monitor outputs
- Headphone output with level control
- Two effect sends, one of which is switchable to Tape Cue
- 3-3/4 i.p.s. high tape speed
- dbx® noise reduction
- Optional RC-30P punch-in pedal

The six components of a complete multitrack studio

Recording starts with the sources you want to record, for example, microphones and electronic instruments.

These are plugged into a mixer, which sends the signals to the multitrack.

The multitrack plays the signals back through the mixer, which is usually connected to effects processors that add reverb, distortion, echo, etc.

In order to hear everything, you need speakers and an amp (which can be your home stereo to start out with).

Finally, you need to mix down to a

2-track CD or cassette, to share your work with other people.

These six components are often combined. TASCAM Portastudios combine the mixer and multitrack in a single unit. A Pocketstudio adds MIDI instruments and a microphone, plus effects processors. Computer systems may add a built-in CD recorder.

Even though elements are combined, it helps to understand them as separate blocks.

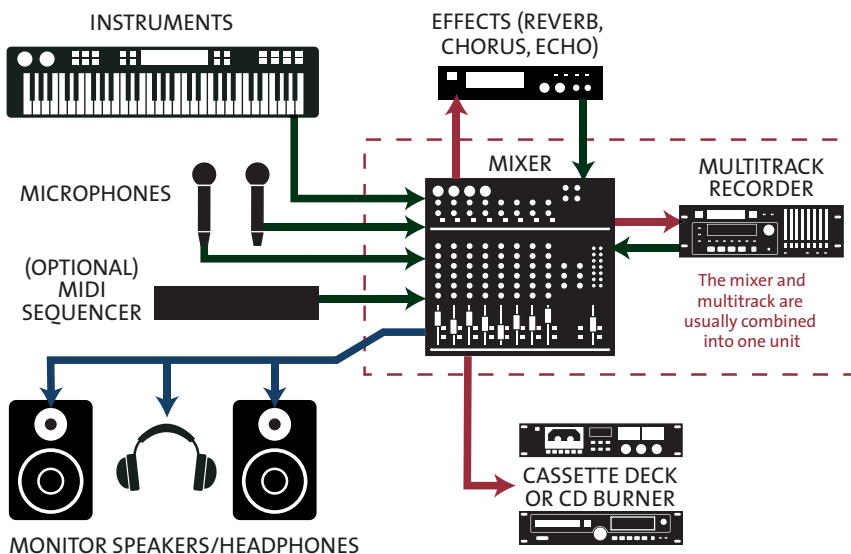

- 4-track simultaneous recording with logic-controlled 4-track tape transport and dbx® noise reduction.
- ±12% pitch control
- RTZ and 2 locate points, repeat function, auto punch I/O with rehearsal function and more
- 6 full-function input channels with MID sweepable 3-band EQ, 2 aux sends for effects processing
- Four assignable XLR Microphone inputs
- Dedicated 1/4" stereo inputs (channel 7-8)
- Separate main L-R and monitor outputs
- Dedicated 1/4" tape outputs
- Sync output

Getting started with multitrack recording: cassette tape Portastudios

Number of tracks: 4

Number of mixer channels: 1 to 6

Recording medium: analog cassette tapes

Mixdown to: external cassette or CD recorder

Extras: none

TASCAM's Portastudios® are the easiest and least expensive way to get started in multitrack recording. The **MF-P01**, **Porta02 mkII**, **414 mkII**, and **424 mkIII** are 4-track tape decks complete with sound mixers. They record on the same blank cassette tapes you can buy anywhere and connect to all standard electronic instruments, speaker systems, and microphones. Because of noise reduction technology (and in some cases a faster tape speed), the sound quality is very good even though it's not digital.

On these TASCAM Portastudios, you can record up to four separate tracks or channels on a cassette tape.

What are the differences between the Portastudios?

The biggest differences are the mixers. For example, on the Porta02 mkII, the mixer has only two inputs, so you can't record

more than two tracks at a time. It also has no effect send, so you can't add reverb or other effects while mixing down. The 424 mkIII lets you record up to four tracks at once from its six-input mixer, has two effects sends, a sweepable midrange EQ on each channel, and four high-quality XLR inputs for low-impedance microphones. Another difference is that the larger Portastudios have better sound quality because of dbx noise reduction and faster tape speeds.

If you plan on getting together with friends to record several instruments at once, the 414 mkII or 424 mkIII is probably your best choice. If you like to work alone, even the MF-P01 can do the trick.

Linear or nonlinear?

Portastudios use tape which makes editing more difficult than on the other products. For example, if during the overdubbing process you come up with an idea for a new section in-between two verses, you'll have to erase the second verse (by recording the new bridge over it) and re-record everything after it. By contrast, all the other multitrack systems we'll talk about later are nonlinear, which means they allow you to insert new material in-between other sections without having to re-record anything.

However, most people start tracking only after the structure of a song is complete, so layering and punching-in is more important than cutting up sections.

PORTA02 mkII

Pan Controls (four)

Output Level Controls (four)

These knobs control the playback levels of the tracks you've already recorded during overdubbing and mixdown.

Input Level Faders (two) These faders set the level of the microphone or instrument as you're recording them.

Level Indicators (two)

424 mkIII

3-band (high, mid, low) equalization

Midrange EQ gives you more control over the tone of each track in a mix.

The two EFFECTS knobs on each channel determine how much signal goes to an external effect device like a reverb, so each track can have the right amount of effect (a lot on a vocal, not so much on a guitar).

Pan Controls (six)

Level Controls (six) adjust both input and output levels

Level Indicators (six)

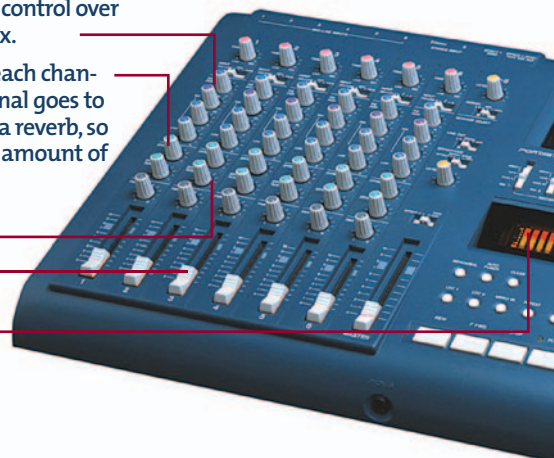
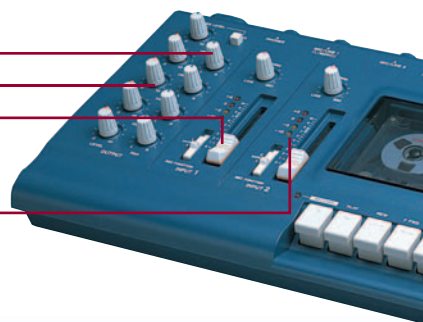

Make the Pocketstudio 5 your own private backup band

Number of tracks:
4 plus up to 16
“virtual” tracks

Number of mixer channels: 2 inputs,
4 faders

Recording medium:
Compact Flash
memory cards

Mixdown to: MP3 files
(internal), external
cassette, CD-R
(via computer)

Extras: 3 effect processors,
MIDI arranger, 16-voice
General MIDI tone
generator with MIDI IN

What if you're beginning to have ideas for your own songs, harmonies, or arrangements, but don't know how to get them out of your head and onto a recording? You could wait until you've learned how to write and play every instrument in a band before you get started. Or, you could get a **Pocketstudio 5**: TASCAM's stand-alone music workstation for people who want to express musical ideas, but can't do everything themselves.

The Pocketstudio 5 is a perfect “step up” for musicians who started out playing along with CDs or singing to karaoke machines and are ready to advance to the next level of musical understanding. It lets you be musical in a fun framework that's flexible enough to start writing your own songs. To call it an “entry-level” product doesn't do it justice, because there is a lot of potential built into this little under-\$500 device.

From the outside, it looks somewhat like a small 4-track recorder,



■ 4-track digital Pocketstudio

■ Up to 9 songs per card

- Mac OS 10.1 and higher support
- Record four digital audio tracks on Compact Flash media
- Internal synthesizer module for playback of MIDI sequence files
- Over 100 built-in high-quality effects for vocals, guitars and other instruments
- Audio/MIDI editing: copy/paste to exact bars/beats, bounce tracks, automate punch-in/out
- USB port for interfacing your music with Mac® and Windows® computers
- Mix down to MP3 format for putting your music on web sites and emailing to friends
- Playback MP3 audio files
- Includes 100 song styles that can be re-arranged to create original music
- Built-in condenser mic included
- Headset mic included
- AC power supply included
- 32MB Compact Flash card included up to 256k cards optional)



but it also contains a “band-in-a-box” or auto-accompaniment device. This means that the Pocketstudio has electronic instruments (such as keyboards, bass, and drums) built right in. These internal instruments can be played by the internal MIDI Arranger, giving you backing tracks in a variety of styles without having to know anything about “MIDI” or “sequencers” (but it will expand your knowledge and let you grow in that direction). That gives the

Pocketstudio the power of an 8-track recorder, since the rhythm section is handled internally via these MIDI “virtual tracks,” leaving the four digital audio tracks open to record live vocals, guitars, or anything you want.

For example, the Pocketstudio lets you select a background style (like “hard rock,” “jazz,” or “country”) that’s not a specific song. This accompaniment isn’t a recording...it’s actually playing the drums, bass, keyboards and other instruments in real time through its internal synthesizer. It’s not quite a “sequencer” (where you’d have to program every single drum and every note of every chord), but it’s much more than just a sequence playback device.

Growing into songwriting.

Most people get interested in multitrack recording equipment to help them with songwriting and arranging. Songwriters have a lot of things to struggle with, and just

Basic Pocketstudio 5 connections.

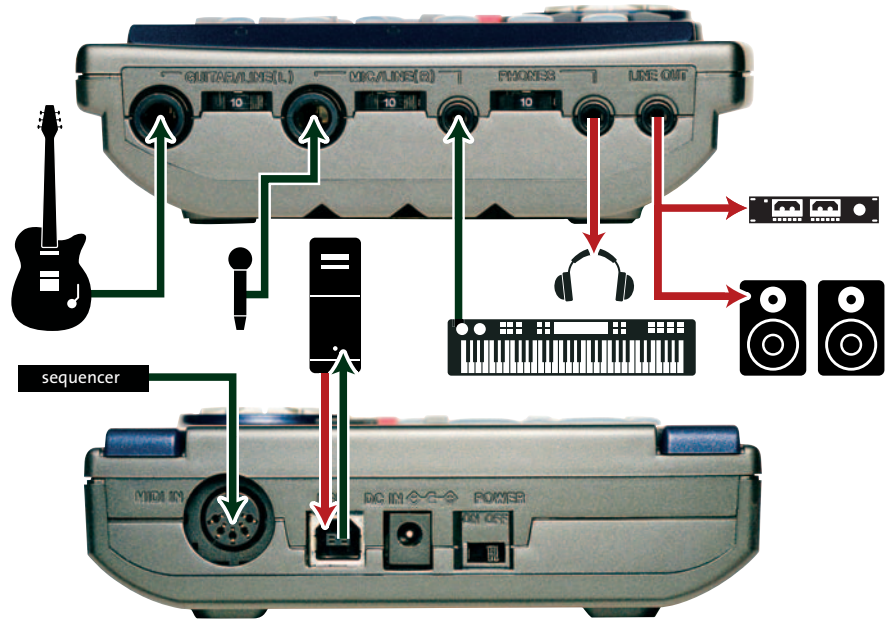

having a drum beat to play with can be a big help. Add a bass part and a keyboard part playing open, general arrangements, and it’s easier to start improvising a melody to those words you jotted down on a napkin last night. The Pocketstudio 5 even provides a headset mic and can run on batteries so you can work on lyrics and melodies while you’re walking down a country road.

New songs don’t always fit into pre-established beats, keys and arrangements. This is where the Pocketstudio goes beyond a “beat box” or “auto-arranger.” You can change the key, harmonies and structure of any arrangement after its initial built-in style has inspired you. As long as you understand the difference between a C major chord and an

E minor chord, you can program the Pocketstudio to play different chords than what came in the “standard” arrangement at any point.

Digital recording with no moving parts.

The Pocketstudio records its audio tracks onto Compact Flash cards instead of tape. A 32 MB card is supplied, which gives you about 10 minutes of 4-track recording plus 10 minutes of 2-track mixdown time, and you can double or quadruple that time with larger cards available at electronics and office supply stores. The sound quality is very good, competitive with the best cassette recorders and similar to commercial MP3 units. Recording onto solid-state memory cards is trouble-free and allows nonlinear editing with simple copy and paste commands. There are built-in effects (like reverb, distortion, chorus) and even a guitar tuner!



Building creative networks via your computer.

The Pocketstudio's mixdown format is MP3, a compressed data file used to send audio over the Internet. If you have a computer with a USB port, you'll be able to post your finished songs on a web site or email them to friends, collaborators and publishing companies. TASCAM has established the **Pocketstudio Network** so you can get together with other musicians to write and record over the Internet. 

Taking it beyond the box.

As you grow as a songwriter and musician, you'll find there are more things you can do to stretch

```
CtGrY: Rock 1
StYle: 60sHrock
Tempo: ♪ = 100
Arrge: Preset
```

The Pocketstudio has 100 built-in preset backing arrangements, selectable by category (in this case, "Rock 1") and style ("60s Hrock", an abbreviation of "1960s hard rock"). You can change the tempo and key of each arrangement, and make them your own.

128 instruments including

Harpsicord
Marimba
Church_OrG
Steel Guitar
Fretless
Cello
SlowString
Trumpet
SoPranoSax
Bassoon
Sitar
SteelDrums
Gunshot

100 song styles including

GlamRock
LatinRock
Motown
DrumNbass
House
Grunge
FastBeBoP
Ska
Western
HighTec
BlueGrass
HiPHoP
Re99ae1

the capabilities of the Pocketstudio. You'll want to control the specific notes played in a chord, or customize a drum fill. No problem—the Pocketstudio can import detailed arrangements in the "Standard MIDI File" (SMF) format. SMFs can be downloaded from the Internet, or written from scratch in most MIDI sequencers.

The next step.

Eventually, you'll run into other musicians who want to work with you, in real time. The Pocketstudio will still be great as a writing tool, but with only two inputs "live" for recording at a time you're limited to overdubbing most parts.

The time has come to look at the next step in your musical and technical development. What tools will you need? Perhaps you need something more elaborate than the units we've described so far. This depends on how you write and perform, and what you find inspiring:

- If you have some keyboard skills and are turning into a composer with ideas for every part of an arrangement, you'll probably be happiest with a computer-based digital audio workstation.
- If you're a musician or singer whose best ideas spring from the moment, or if you're just turned off by computers, you'll be happiest with a top-quality multitrack recorder/mixer. Let's look at that next.



- 8-channel digital mixer with 7.5 gigabyte built-in hard disk for nearly two hours of 8-track recording
- 8 track, 24-bit or 16-bit linear recording with 250 virtual tracks per song, 999 levels of undo/redo and more
- Non-destructive editing (copy, paste, insert, move, cut, clone track, more)
- Two advanced internal effects processors with compression, reverb, distortion, chorus and much more
- Four 1/4" mic/line inputs with 4th input switchable to Guitar Level with processing
- Two 1/4" AUX outputs
- RCA stereo aux inputs, stereo outputs and monitor outputs
- 1/4" headphone output
- MIDI in and out
- SCSI port for connection to external hard disk or...
- Optional CD-RW788 rewriteable CD recorder for stereo mixdown to CD and data backup

US-122



- USB audio/MIDI computer interfacing
- Mac® and Windows® compatible
- Two XLR-fed phantom-powered mic inputs with inserts
- Two line level inputs (switchable to guitar level)
- 16 channels of MIDI I/O
- Adjustable zero-latency direct monitoring
- Two line outputs with level control
- Headphone output with level control
- Self-powered via USB: perfect for both studio and location recording
- Includes ASIO, WDM, GSIF and Apple Core Audio (OS X) drivers
- Includes audio recording/MIDI sequencing software
- Includes GigaStudio 24 sampling workstation software
- Compact and rugged steel construction

Ultimate 8-track: the 788 Digital Portastudio

Number of tracks: 8
(6 recordable at once)

Number of mixer
channels: 8

Recording medium:
internal hard disk (over
3 hours of 8-track at
16-bit, capable of 24-bit),
expandable with
external SCSI drives

Mixdown to: optional
CD recorder or external
cassette

Extras: two effects
processors, mixer
automation, MIDI sync,
internal tempo map/
metronome

TASCAM invented the Portastudio many years ago, and has brought the mixer/multitracker into the digital era with the **788**. The faders and transport controls work the same way they do on a cassette Portastudio.

But we'll admit it — with dozens of switches and lights, and some cryptic names on its top panel, the 788 can be intimidating when you first look at it, especially if you've never recorded before. Don't worry — the 788's "QUICK SETUP" button is designed to help you out. One push sets all the mixer controls to the

Source selection (Inputs A-D, Aux inputs, Track or stereo Input trim controls (four) (inside) hard disk

Effects 1 and 2 buttons
EQ, Send and Fader/Pan buttons work with LCD screen



Track Assign (seven buttons serve eight channels)
Record Ready buttons
Channel faders (seven)

Jog/Shuttle wheel
Editing controls
Transport controls
Cursor controls
Master fader

right settings for tracking, another push sets them for mixing. So, you can be clueless about what some of the buttons do, and still start recording.

When you need no-compromise sound quality.

Of the TASCAM products described so far, the 788 leads the pack in sound quality. Our cassette Portastudios are good, and the Pocketstudio is digital, but the 788's 24-bit digital recording and excellent analog-to-digital

converters are state-of-the-art.

What does that mean? It means that the 788's frequency response is wider, and the noise is lower, than previous generations of analog or digital multitracks, resulting in better-than-CD sound quality. Essentially, what you plug into the 788 is exactly what you'll get out of it—no extra noise or hiss.

Hidden features of the 788's digital mixer.

The 788 has 8 faders and 4 trim knobs, but you don't see any other knobs for EQ and effects sends. That

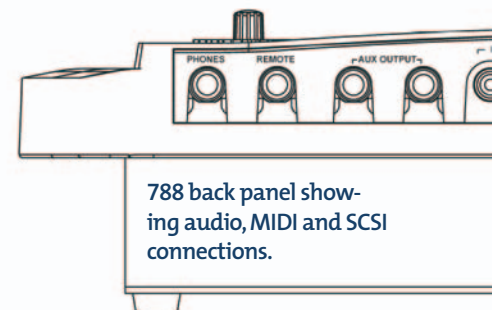

788 back panel showing audio, MIDI and SCSI connections.

doesn't mean they're not there, however. The "knobs" are digital and can be commanded from the LCD screen. In fact, the 788 has the equivalent of over fifty "knobs." What you give up by losing knobs, you gain by having *snapshot automation* that stores your favorite "knob setups" for all the channels at once in computer memory. Each song can have up to ten snapshots, so you can change the mix for each verse, chorus, solo, etc., automatically.

MIDI compatible.

The 788 doesn't have a MIDI sequencer or any internal instruments of its own, but it can synchronize to



Not only is the 788 easy to use, but it's quite powerful. The built-in editing capabilities could be used to cut out a cough or phone ring in the middle of a great take, loop a drum beat, or duplicate well-sung chorus vocals. The wave form screen with audio scrubbing offers a simple visual reference.

an external sequencer via MIDI, and receive transport commands (play, fast forward, etc.) from an external controller (this is called *MIDI Machine Control*). This division of labor between audio and MIDI is perfect for those who already have hardware sequencers.

Pushing the envelope

If you need more inputs (for example, several synthesizers at once) you'll probably want to get an external mixer for the keyboards and plug it into the 788's stereo AUX inputs.

But if your music is heavily keyboard-based, and you have computer skills, you'll probably find it easier to combine MIDI sequencing and digital audio multitracking in a personal computer. That's where the next category of TASCAM gear comes in.

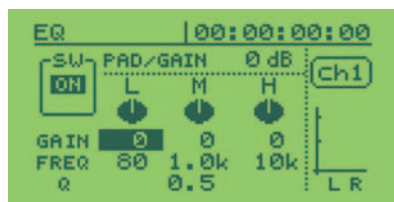

This LCD screen shows how you change the EQ (tone) on a channel of the 788. There are 3 bands of EQ (Low, Mid, and High), each with adjustable frequencies (shown set to 80 Hz, 1 kHz, and 10 kHz). Currently all of the bands are flat (no cut or boost). The Low Gain (bass boost) is selected and can be increased or decreased by moving the large JOG/DATA wheel. If you wanted to change the Mid EQ gain, you'd simply press the right CURSOR key until it was highlighted and change it with the DATA wheel as well.

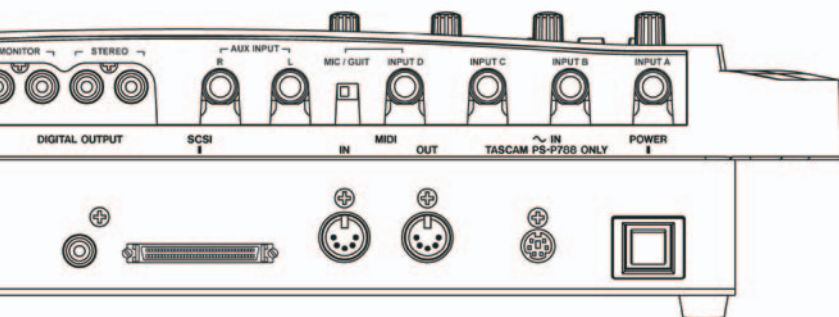

- USB audio and MIDI interface for Mac and PC
- Compatible with many popular audio multitrack software applications; includes version of Steinberg Cubasis VST for Mac and Windows
- 24-bit A/D/A resolution; 44.1 or 48 kHz sampling rates
- Four channel strips plus master fader control surface
- Two analog inputs (1/4"); S/PDIF digital input & output; Stereo RCA analog outputs; MIDI In / MIDI out
- Transport controls, Data/Shuttle Wheel, Solo/mute switches, Headphone jack
- Self-powered via USB...no external power supply required



- USB audio and MIDI interface for Mac and PC
- Compatible with many popular audio multitrack software applications; includes version of Steinberg Cubasis VST for Mac and Windows
- 24-bit A/D/A resolution; 44.1 or 48 kHz sampling rates
- 8 channel strips plus master fader control surface
- 4-band EQ control, Transport controls, Data/Shuttle Wheel, Solo/mute switches, Headphone jack
- Four analog inputs (XLR, balanced line and Hi-Z); S/PDIF digital input & output; Stereo RCA analog outputs; 2x MIDI In / 2x MIDI out
- Four analog or two analog and two digital inputs can be recorded at once

Getting your music into and out of a computer with the US-224, US-428 and US-122.

Number of tracks:
8-24 depending on your computer

Number of inputs:
2 to 4

Recording medium:
computer hard drive,
back-up by CD-R or DVD-R

Mixdown to: computer CD-R or DVD-R drive

Extras: mixer automation, plug-in effects, MIDI sequencing, MIDI inputs and outputs

Personal computers are everywhere today...they're incredibly powerful, reliable, and relatively inexpensive. Computers and music make a natural combination because music can be expressed in numbers. Many of the best software programmers are also musicians, so as a result there's a lot of great music software around. Software such as Steinberg's Cubase® and Nuendo® has made it easier to compose and arrange music...and lets the composer hear the "orchestra" as they write.

The software program that writes and plays back the notes is called a

sequencer. Almost every electronic instrument (keyboard, organ, piano, drum machine) has a MIDI IN jack so it can be "played" by a sequencer and a MIDI OUT jack so anything played on the keyboard can be recorded by the sequencer.

How a computer sequencer helps you write and record your music.

This might be a little confusing, but keep in mind: a MIDI sequencer doesn't record the sound of the keyboard. Instead, the computer is telling the keyboard things like, "Play a low G# now." The computer is acting like "virtual fingers" on the keyboard. The sound is generated directly from the keyboard itself, "live."

If you're not a keyboard player, but you do understand basic harmonies and music theory, a computer sequencer will let you enter notes one at a time, placed exactly where you want them. It will then play back the sequence of notes, and let you make changes on the computer screen. If you read standard music notation, many sequencers will let you enter the data by placing notes on a staff. Most programs also feature a "grid" of notes that many musicians find easier to deal with.

If you *do* play keyboards, a sequencer can edit out mistakes, like a word processor, making corrections you couldn't make with a multitrack—such as erasing a single wrong note inside a chord. Sequencers also allow you to quantize the notes: if you play a little bit off the beat, the computer can "pull" your notes so they hit right on the beat.

Once you've entered the notes into the sequencer, you can change the speed or tempo of the music, without changing the key (something you couldn't do with an analog tape recorder).

Going beyond sequencers: Digital audio workstations.

A MIDI sequence can be a great basic track to a song, and may be all you need for an instrumental track. But not everything can be sequenced, notably guitars and vocals. That's where the marriage between a MIDI sequencer and digital audio recording comes in.

A human being singing into a microphone is still the most important part of a successful

The components of a multi

Compare this drawing to the one on page 3 of this booklet.

Same six components but now some of the functions are being handled by the computer.

Multitrack recording is now a function of the Digital Audio Workstation (DAW) program and your computer's

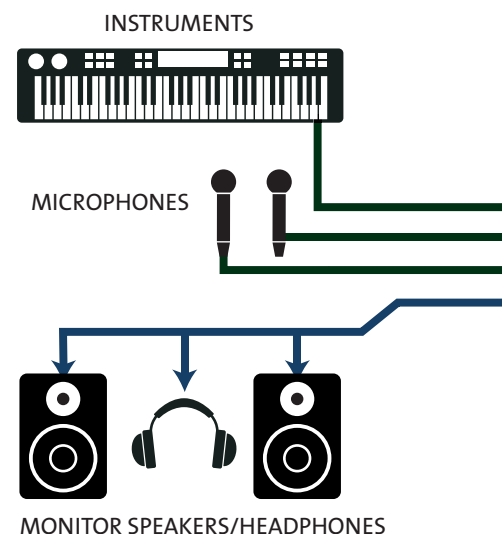

song. Today's music software, like Steinberg's Cubase, can record audio tracks and MIDI tracks in the same program, side-by-side. This has a lot of advantages, especially when you're experimenting with a song's structure. Want to repeat the chorus? Simply copy and paste all the audio and MIDI data in the new location. Want to add a bridge between two sections? Don't start from scratch—simply create new space in the middle without erasing anything. For people who come up with new ideas all the time but don't want to re-do tracks over and over again, the digital audio workstation is a godsend. This is a real advantage over "linear systems" (like the Portastudios) that use tape.

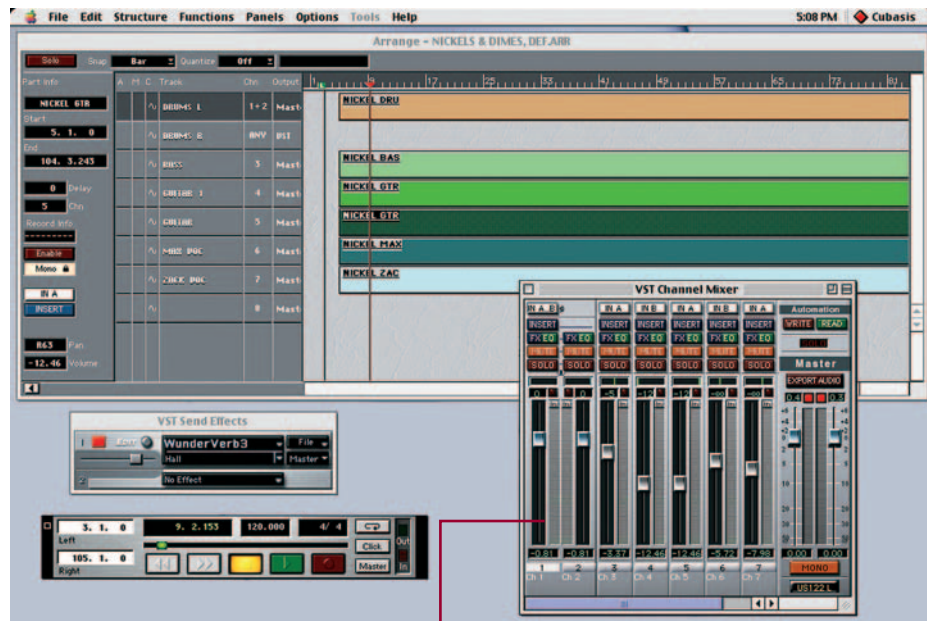

Steinberg's Cubasis, a basic digital audio workstation/sequencer program that ships free with the TASCAM US-122, US-224 and US-428. Note the "virtual" mixer that can be mapped to US-224

or US-428 faders for hands-on control. TASCAM computer interfaces can also be used with more complex DAW programs such as Nuendo, Digital Performer, Logic Audio, etc.

track studio revisited.

hard disk. MIDI sequencing is also controlled through the computer.

On the other hand, the US-224 Interface provides the functions of the mixer in our first drawing, as well as better access to DAW functions such as transport controls.

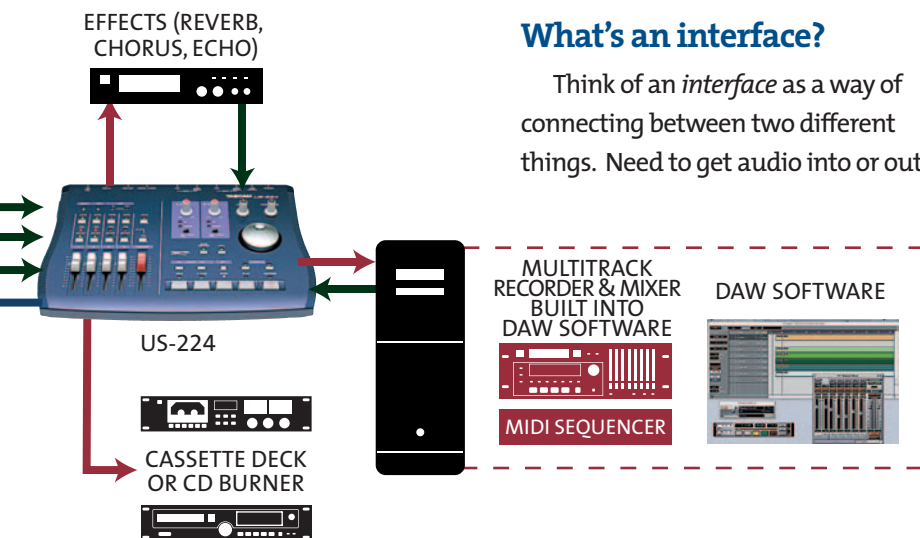

Some computers come with a tiny speaker for playing back computer-generated tones, others might even have a microphone, but they're usually meant more as a minor accessory than for serious recording. If you want to use a computer as a digital audio workstation (DAW), you'll need an interface.

What's an interface?

Think of an *interface* as a way of connecting between two different things. Need to get audio into or out

of a computer? You need an audio interface. Want to get MIDI data in and out so you can "play" a keyboard from a computer sequencer? You need a MIDI interface. The arrangement of windows on a computer screen may be called a *user interface*, because that's where you "connect" with the software. The computer connects with the outside world with a USB interface, or to a hard disk with a Firewire interface.

Making a computer into a digital audio workstation with TASCAM interfaces.

TASCAM makes three multipurpose interfaces that can bridge the gap between the computer and your music. We call them "multipurpose" because they act as an audio interface, a MIDI interface, and a fader

control surface simultaneously. The **US-428**, **US-224** and **US-122** connect to a computer via its USB port. See pages 11 and 13 for details.

The US-428 and US-224 look very similar to the tape-based Portastudios we talked about before. Like the Portastudios, the difference between the US-428 and US-224 is primarily in the number of channels and controls. Both of them come with a free version of Steinberg's **Cubasis VST** software, and are compatible with more advanced software from Steinberg and other companies.

The great thing about these interfaces is that you don't need to purchase a separate mixer. The US-428 has 4 audio inputs complete with mic preamps, XLRs, (the 3-pin connectors used with professional low-impedance microphones) and 1/4" connectors, so you can plug in your microphone, guitar, or keyboard. It also has two sets of MIDI IN and MIDI OUT jacks for controlling external synthesizers. It has four *analog-to-digital converters* which change the sound into a stream of numbers that can be read by the computer soft-

ware and recorded onto hard disk. The US-224 has 2

analog inputs. Both have S/PDIF inputs and outputs (which connect to external digital devices like CD-Rs), headphone outputs, and transport control switches.

About virtual audio channels.

Unlike the analog Portastudios, computer software can have many more channels than there are corresponding faders on the top panel of the US-224 and US-428. For example, up to 8 with Cubasis VST and as many as 64 with some DAW programs. It doesn't matter that the US-428 has only 8 physical faders on its top panel, or the US-224 has only 4; those faders can be assigned to control any of the channels in the software.

The faders don't actually control the audio level directly—instead, they act as controllers sending messages to the computer, which actually does the "mixing." But that's just a detail...as far as you're concerned, you simply reach for a fader to change the level of a track, just as you would in a traditional non-computerized studio.

This expandability is one of the big pluses of going the computer route—it may look like an 8-track on top, while it's controlling 48 tracks

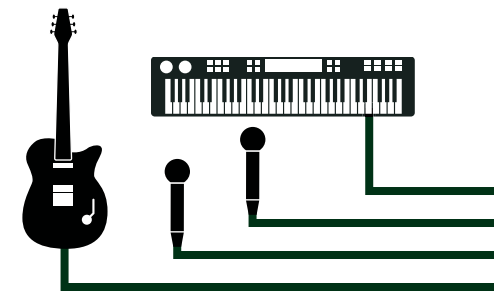

Basic US-428 connections.

in the software. It's perfect if you're someone who likes to build a wall of sound with no limitations. Many software packages also provide a way to record several different alternate "takes" in one track, and (for example) compile the best phrases or even words from different takes into a final vocal.

What the computer needs to record audio on the hard disk.

Make sure you have enough space before you record. Multitrack audio uses a lot of disk space—over 8 megabytes per minute per 24-bit track. If you record 10 tracks for 5 minutes, you've occupied over 400 MB. Luckily, large hard drives are cheap now. You can get fast drives with 80 gigabytes or more for



A USB cable specimen (*QuickusConnectus ComputerInterfaceae*).

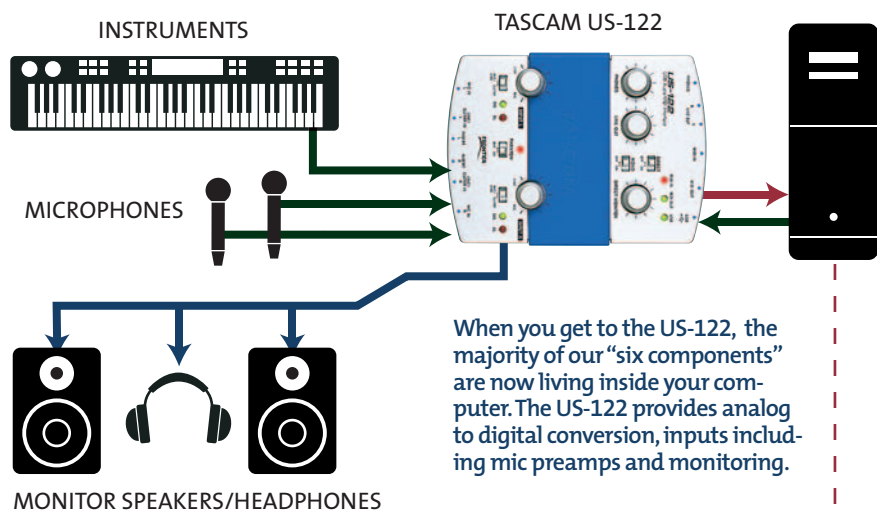

When you get to the US-122, the majority of our "six components" are now living inside your computer. The US-122 provides analog to digital conversion, inputs including mic preamps and monitoring.

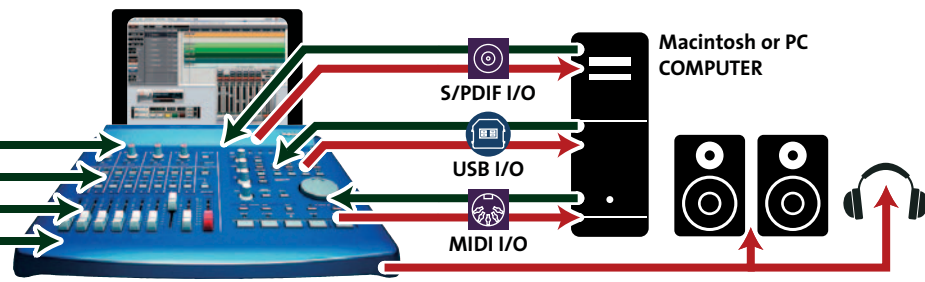

about \$100. Most computer stores or knowledgeable friends can connect the drives for you.

It's good to have a lot of computer memory, too — 128 MB will work, but 256 MB is better; 512 MB will keep you out of trouble if you're running a lot of effects and tracks.

Finally, you'll need to have something to back up with, since you can't keep your music on the hard drive forever. Most musicians use recordable CD drives, which make both CD-ROMs to store the multitrack data, and audio CDs to play the stereo mix-downs. TASCAM's parent company TEAC makes CD-Rs and DVD-R drives that work well with any PC or Mac.

The US-122.

Our new **US-122** foregoes faders, displays and controls to provide an

incredibly compact "bridge" for getting audio into your computer. It features two XLR-based, phantom-powered mic inputs.

As one of the only small computer interfaces with analog inserts, you can use the US-122 to place hardware devices (compressors, etc.) into the recording signal chain. Two line-level inputs on balanced 1/4" TRS jacks are included, and are switchable to guitar-level for direct instrument recording into your computer.

In addition to audio interfacing, the US-122 gives you 16 channels of MIDI I/O for use with synthesizers and other sound generating equipment.

Computer-based DAWs have incredible potential.

They give you virtually unlimited recording space and the ability to try different variation without losing your original.

However, keep in mind that they present certain hassles that not everyone enjoys dealing with such as optimizing the hard drive, software conflicts, crashes, viruses, updates, etc. When you first start out, it may take a while before you get all the "bugs" out of a system. So, it helps to have a friend or dealer you can call on to answer specific questions. This will save you a lot of time.

Having said that, many people just find a non-computer recording system easier to use. This is especially true if you only record occasionally; it's easy to forget some of the software commands if you haven't turned on the computer for a few weeks.

Need more information?

We hope this Guide has given you an idea of all the different multitrack technologies TASCAM has developed, and how you might be able to use it to take your music to the next level. The next step is to narrow your focus to the products that seem right for you, and to try them out at your TASCAM dealer. You might want to prepare by downloading more information about specific products from www.tascam.com. You can even read the manuals first if you want. But there's no substitute for having a knowledgeable salesperson show you the ropes. TASCAM dealers have gone through special training programs designed to help them help you.



INTERNAL OR EXTERNAL CD BURNER



MIDI SEQUENCER



DAW SOFTWARE



REVERB, CHORUS, ECHO ETC. VIA DAW PLUG-INS

MULTITRACK RECORDER BUILT INTO DAW SOFTWARE



VIRTUAL MIXER BUILT INTO DAW SOFTWARE



No matter what your level of expertise musically or technically, no matter what kind of music you play, we know that multitrack recording can be a valuable artistic tool. We hope we've helped you find the right equipment for you. Good luck with your music!





CAPTURE YOUR ART!

www.tascam.com



TEAC CORPORATION

3-7-3 Nakacho • Musashino-shi • Tokyo
180-8550 JAPAN • +81-422-52-5082
www.tascam.com

TEAC AMERICA, INC.

7733 Telegraph Road • Montebello
CA 90640 USA • +1-323-726-0303
www.tascam.com

TEAC CANADA LTD.

5939 Wallace Street • Mississauga
Ontario L4Z 1Z8 • CANADA
+1-905-890-8008 • www.tascam.com

TEAC MEXICO, S.A de C.V

Campesinos N°184 • Colonia Granjas
Esmeralda Delegacion Iztapalapa
CP 09810 Mexico DF MEXICO
+52-555-581-5500 • www.tascam.com

TEAC UK LIMITED

5 Marlin House, Croxley Business Park
Watford Hertfordshire • WD18 8TE
UNITED KINGDOM • +44-1923-438880
www.tascam.co.uk

TEAC DEUTSCHLAND GmbH

Bahnstrasse 12 • 65205 Wiesbaden-
Erbenheim GERMANY • +49-611-71580
www.tascam.de

TEAC FRANCE SA

17 Rue Alexis-de-Tocqueville • CE 005
92182 • Antony Cedex FRANCE
+33-1-42-37-01-02
www.tascam-europe.com

TEAC BELGIUM NV/SA

PATEAC NEDERLAND BV • Oeverkruid
15 • NL-4941 VV Raamsdonksveer
NETHERLANDS • +31-162-510860
www.tascam-europe.com

TEAC NEDERLAND BV

Oeverkruid 15 • NL-4941 VV
Raamsdonksveer NETHERLANDS
+31-162-510210
www.tascam-europe.com

TEAC ITALIANA S.p.A.

Via C Cantu 11 • 20092 Cinisello
Balsamo • Milano ITALY
+39-02-66010500 • www.teac.it

TEAC AUSTRALIA PTY., LTD.

280 William St • Melbourne • Victoria
3000 AUSTRALIA • +61-3-9646-1733
www.teac.com.au

© 2003 TEAC Corporation. All trademarks are the property
of their respective holders. All rights reserved. Design and
specifications subject to change without notice.
PRINTED IN USA TAS/85684/CP/603/35K

TASCAM®

7733 Telegraph Road
Montebello, California 90640
323.726.0303