



NOTES:

1. SYMBOL  INDICATES MOUNTING POINT, 1/4-20 THREADED HOLE (CASTER).
2. SYMBOL  INDICATES RUBBER FOOT.
3. SYMBOL  INDICATES CENTER OF BALANCE.
4. WEIGHT APPROX. 113 LBS.
5. SHIPPING WEIGHT APPROX. 132 LBS..

REV	DESCRIPTION	APVD/DATE
1	REVISED PER ECO #4923 DM 10/11/00.	KFH 10/13/00

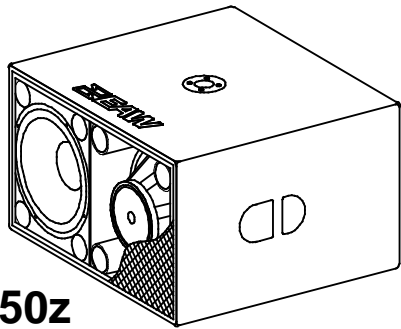

FR250z

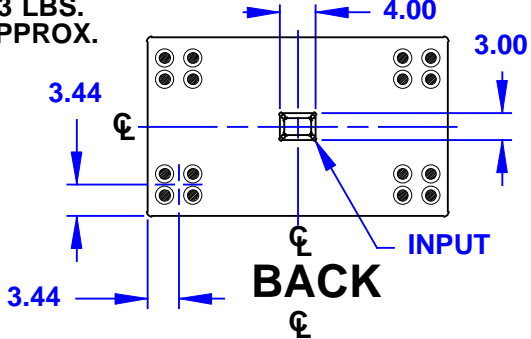

BACK

POLE MOUNT SOCKET

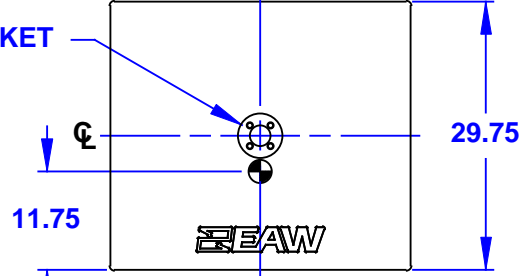

TOP

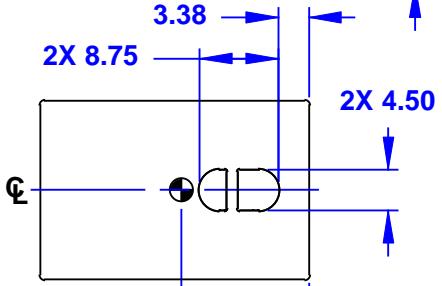

LEFT SIDE

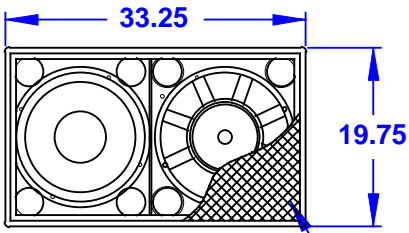

FRONT

GRILLE PARTIALLY SHOWN

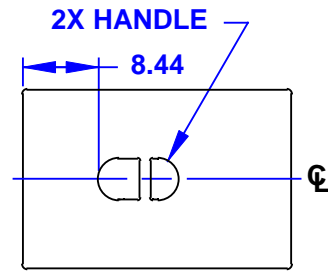

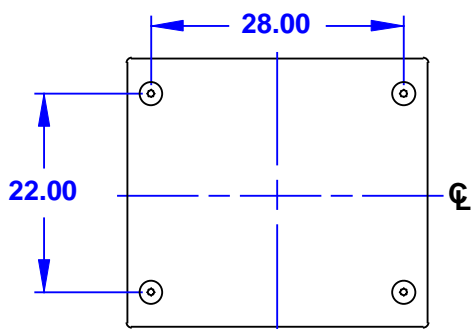

RIGHT SIDE

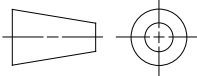

BOTTOM

DOCUMENT CONTROL PER SPECIFICATION 4.5.201

	UNLESS OTHERWISE SPECIFIED: ALL DIMENSIONS ARE IN INCHES TOLERANCE IN INCHES .XX ± .13 ANGLES ± 1° (X.XX) = REF DIMS NO TOLERANCE IMPLIED T.S.C.=THEORETICAL SHARP CORNER DIMENSIONS ACROSS CENTERLINES TO BE SYMMETRICAL	STATUS: PRODUCTION		 EASTERN ACOUSTIC WORKS ONE MAIN STREET WHITINSVILLE, MA 01588 USA	
		APPROVALS	DATE		TITLE: CABINET/FINISHED/FR250z [MECHANICAL SPECIFICATION]
THIS DRAWING IS THE PROPERTY OF EAW AND SHALL NOT BE COPIED, REPRODUCED, OR USED AS THE BASIS FOR MANUFACTURE OR SALE OF APPARATUS WITHOUT WRITTEN AUTHORIZATION. DO NOT SCALE DRAWING.		DRAWN: MFL	7/19/99	A SHEET 1 OF 1	SCALE: 1 TO 20
		CHECKED: FEL	3/29/00		
		DES ENG: RJM	3/31/00		
		MFG ENG: DBD	4/6/00		