

# STEALTH WASH ZOOM

**Introduction:**

The Stealth Wash Zoom is a unique DMX intelligent moving head unit. The Stealth Wash Zoom has 3 operating modes; sound active mode, show mode, or controlled via DMX controller. The Stealth Wash Zoom has 2 DMX Channel modes; 5 or 16 channels. The unit can be run as a stand alone unit or in a Master/Slave set up. This unit has been tested and there is no assembly required. Follow the instructions on the following pages to operate your fixture. To enhance the beams effects you can use a fog machine.

**CAUTION!** Please read and understand these instructions before installing or operating this unit.

**CAUTION!** Please read and understand these instructions before installing or operating this unit.

**Fuse Replacement:** Locate and remove the unit's power cord. Once the cord has been removed, the fuse holder is located inside the power socket. Insert a flat-head screw driver into the fuse holder and gently pry out the holder. Remove the bad fuse and replace with a new one. The fuse holder has a built-in second holder for a spare fuse.

**SPECIFICATIONS:**

<b>Model:</b>	Stealth Wash Zoom
<b>Supply Voltage:</b>	100V-240V 50/60Hz
<b>LED:</b>	7 x 12W RGBW LED's
<b>Weight:</b>	10lbs./ 4.5 kgs.
<b>Size:</b>	6.22" (L) x 9.4" (W) x 12.63" (H)
<b>Fuse:</b>	2 Amp
<b>Power Consumption:</b>	95W
<b>Working Position:</b>	Any Safe position
<b>Duty Cycle:</b>	None
<b>DMX Channels:</b>	2 DMX Channel Modes: 5 Channel Mode & 16 Channel Mode
<b>Colors:</b>	RGBW
<b>Warranty:</b>	1 Year

**AXXX:** In this menu you can set the DMX address. Press the Up or Down buttons until “AXXX” is displayed. “XXX” is the current displayed DMX address. Press Enter and use the UP or Down buttons to find your desired address. When you have found your desired address press the Enter button to set it.

**CHNd:** The Stealth Wash Zoom has 2 DMX channel modes; 5 channel mode and 16 channel mode. In this menu you can select your desired channel mode. Press the Up or Down buttons until “CHNd” is displayed and press ENTER. Either “16CH” or “5CH” will be displayed. Use the Up and Down buttons to toggle between the two modes and press Enter to make your selection and press Menu to exit.

**SPNd (Sound Active Speed):** In this menu you can adjust the sound active moving speed. Press the Up or Down buttons until “SPNd” is displayed and press ENTER. Either “Low” (Low Speed) or “High” (High Speed) will be displayed. Use the Up and Down buttons to toggle between the two speeds and press Enter to make your selection. Press the Menu button to exit.

**SLNd (Master/Slave):** In this menu you can designate the fixture as either a Master or Slave in a master-slave set up. Press the Up or Down buttons until “SLNd” is displayed and press Enter. Either “Mast” or “SL 1” will be displayed. Use the Up and Down buttons to find your desired setting and press Enter to make your selection. Press the Menu button to exit

**SHNd (Show Mode):** In this menu you can activate 1 of the 8 show mode’s. Press the Up or Down buttons until “SHNd” is displayed and press Enter. 1 of 8 shows will be displayed. Use the Up and Down buttons find your desired show and press Enter to make your selection. Press the Menu button to exit

**Soun (Sound Active):** In this menu you can activate Sound Active mode. Press the Up or Down buttons until “Soun” is displayed and press Enter. Either “On” or “Off” will be displayed. Use the Up and Down buttons toggle between the choices and press Enter to make your selection. Press the Menu button to exit.

**PAn (Reverse Pan):** In this menu you can reverse the Pan function. Press the Up or Down buttons until “PAn” is displayed and press Enter. Press the Up or Down buttons until “On” is displayed, and press Enter. Press the Menu button to exit. This function works better when you have two units connected in a Master/Slave setup. Have one unit set to reverse Pan and the other unit in normal Pan.

**tIL (Reverse Tilt):** In this menu you can reverse the Tilt function. Press the Up or Down buttons until “tIL” is displayed and press Enter. Press the Up or Down buttons until “On” is displayed, and press Enter. Press the Menu button to exit. This function works better when you have two units connected in a Master/Slave setup. Have one unit set to reverse Tilt and the other unit in normal Tilt.

**dISP (Display):** In this menu you can “flip” the display 180°. Press the Up or Down buttons until “dISP” is displayed and press Enter. Either “ON” or “OFF” will now be displayed. If you want to “flip” the display press the Up button so that “ON” is displayed, and press Enter. Press the Menu button to exit.

**rFAC (Default Setting):** In this menu you can reset the unit to its default settings. Press the Up or Down buttons until “rFAC” is displayed and press Enter. Select “On” and press Enter to revert to default settings. Press the Menu button to exit without any changes.

**rSt (Reset):** In this menu you can activate reset function. Press the Up or Down buttons until “rSt” is displayed and press Enter. The unit will now begin to reset. Press the Menu button to exit.

## **Ad t (OFFSET MENU) -**

To enter the Offset Menu, press the Up or Down buttons until “Ad t” is displayed and press Enter. “P000” will now be displayed. Press the Up button so that the display reads “P018” and press Enter. In this submenu you are able to adjust the home positions of the pan and tilt motor’s, and focus motor. If you select delete, it will reset all home positions to “0000”. Press the Menu button to exit.

### **Ad t:**

**(Delt)** - Selecting this will default all offset values to “0000”.

**(P)** - Use the Up and Down buttons to adjust the offset of the Pan motor.

**(t)** - Use the Up and Down buttons to adjust the offset of the Tilt motor.

**(F)** - Use the Up and Down buttons to adjust the offset of the Focus motor.

### **OPERATION:**

**UNIVERSAL DMX CONTROL:** This unit allows you to use any universal DMX-512 controller to control head movement, LED colors, and the shutter (strobe). A DMX controller allows you to create unique programs tailored to your individual needs. Follow the set-up specifications that are included with your DMX controller.

1. The Stealth Wash Zoom has two DMX channel modes; 5 DMX channels and 16 DMX channels.
2. Press the Up or Down buttons until “Chnd” is displayed, and press Enter.
3. Press the Up or Down buttons until your desired DMX channel mode is displayed, and press Enter.
4. Press the Mode button until “AXXX” is displayed. “XXX” is the current displayed DMX address. Press the Enter button.
4. Use the Up and Down buttons to find your desired address and press Enter.
5. Connect your DMX Controller and use the controller’s faders to control the various DMX fixture traits.
6. For longer cable runs (more than a 100 feet) use a terminator on the last fixture.
7. For help operating in DMX mode consult the manual included with your DMX controller.

### **SOUND ACTIVE MODE:**

1. To activate Sound Active mode, press the Up or Down buttons until “SOUN” is displayed, and press Enter.
2. Either “On” or “Off” will be displayed. To activate sound active mode press the Up or Down buttons until “On” is displayed, and press Enter to select. Press the Menu button to exit
3. To adjust the movement speed in sound active mode press the Up or Down buttons until “SPnd” is displayed. Either “HISP” (High Speed) or “LoSP” (Low Speed) will be displayed. Use the Up or Down buttons to switch between the two modes and press Enter to make your selection. Press the Menu button to exit.

### **SHOW MODE:**

1. To activate Show mode, press the Up or Down buttons until “SHnd” is displayed, and press Enter.
2. 1 of 8 shows will be displayed. Use the Up or Down buttons to scroll through the shows and press Enter to make your selection. Press the Menu button to exit.

**MASTER-SLAVE SET UP:** This function will allow you to link up to 16 units together and operate without a controller. The units can be sound active or in show mode. In a Master-Slave set up one unit will act as the controlling unit and the others will react to the controlling units programs. Any unit can act as a Master or as a Slave.

1. Using approved DMX data cables, daisy chain your units together via the XLR connector on the rear of the units. Remember the Male XLR connector is the input and the Female XLR connector is the output. The first unit in the chain (master) will use the female XLR connector only - The last unit in the chain will use the male XLR connector only. For longer cable runs we suggest a terminator at the last fixture.
2. On the Master unit press the Menu button until “SLnd” is displayed, and press Enter. Use the UP and DOWN buttons to scroll to the “Mast” setting and press Enter. Press the Menu button to exit.
3. After setting the Master unit to the master setting find and set your desired operating mode.
4. On the slave units press the Menu button until “SLnd” is displayed, and press ENTER. Press the Up or Down buttons until “SL 1” and press Enter. Press the Menu button to exit.
5. The slave units will now follow the Master unit.

---

## **DMX TRAITS: 5 CHANNELS**

CHANNEL 1: PAN

CHANNEL 2: TILT

CHANNEL 3: COLORS

0 - 5 = NOTHING  
6 - 10 = RED  
11 - 15 = GREEN  
16 - 20 = BLUE  
21 - 25 = WHITE  
26 - 30 = RED + GREEN  
31 - 35 = GREEN + BLUE  
36 - 40 = BLUE + WHITE  
41 - 45 = RED + BLUE  
46 - 50 = GREEN + WHITE  
51 - 55 = RED + WHITE  
56 - 60 = RED + GREEN + BLUE  
61 - 65 = RED + GREEN + WHITE  
66 - 70 = GREEN + BLUE + WHITE  
71 - 75 = RED + GREEN + BLUE + WHITE  
76 - 127 = COLOR CHANGE SLOW - FAST  
128 - 133 = NOTHING  
134 - 255 = COLOR FADE SLOW - FAST

CHANNEL 4: INTERNAL PROGRAMS

0 - 20 = NOTHING  
21 - 40 = PROGRAM 1  
41 - 60 = PROGRAM 2  
61 - 80 = PROGRAM 3  
81 - 100 = PROGRAM 4  
101 - 120 = PROGRAM 5  
121 - 140 = PROGRAM 6  
141 - 160 = PROGRAM 7  
161 - 180 = PROGRAM 8  
181 - 200 = NOTHING  
201 - 225 = MOTOR RESET  
226 - 255 = NOTHING

CHANNEL 5: FOCUS

0 - 255 = FOCUSING NARROW - WIDE

## **DMX TRAITS: 16 CHANNELS**

CHANNEL 1: PAN

CHANNEL 2: PAN FINE

CHANNEL 3: TILT

CHANNEL 4: TILT FINE

CHANNEL 5: RED

0 - 255 = 0% - 100%

CHANNEL 6: GREEN

0 - 255 = 0% - 100%

CHANNEL 7: BLUE

0 - 255 = 0% - 100%

CHANNEL 8: WHITE

0 - 255 = 0% - 100%

CHANNEL 9: MASTER DIMMER

0 - 255 = 0% - 100%

CHANNEL 10: SHUTTER/STROBING

0 - 9 = SHUTTER CLOSED

10 - 245 = STROBING SLOW - FAST

246 - 255 = SHUTTER OPEN

CHANNEL 11: FOCUS

0 - 255 = FOCUSING NARROW - WIDE

CHANNEL 12: COLOR TEMPERATURES

0 - 255 = COLOR TEMPERATURES

CHANNEL 13: COLOR EFFECT

0 - 10 = NOTHING

11 - 20 = RED

21 - 30 = GREEN

31 - 40 = BLUE

41 - 50 = WHITE

51 - 60 = RED + GREEN

61 - 70 = GREEN + BLUE

71 - 80 = BLUE + WHITE

81 - 90 = RED + BLUE

91 - 100 = GREEN + WHITE

101 - 110 = RED + WHITE

111 - 120 = RED + GREEN + BLUE

121 - 130 = RED + GREEN + WHITE

131 - 140 = GREEN + BLUE + WHITE

141 - 150 = RED + GREEN + BLUE + WHITE

151 - 255 = COLOR CHANGE SLOW - FAST

CHANNEL 14: COLOR FADE

0 - 10 = NOTHING

11 - 194 = COLOR FADE SLOW - FAST

CHANNEL 15: PAN/TILT SPEED

0 - 255 = FAST - SLOW

CHANNEL 16: INTERNAL PROGRAMS

0 - 20 = NOTHING

21 - 40 = PROGRAM 1

41 - 60 = PROGRAM 2

61 - 80 = PROGRAM 3

81 - 100 = PROGRAM 4

101 - 120 = PROGRAM 5

121 - 140 = PROGRAM 6

141 - 160 = PROGRAM 7

161 - 180 = PROGRAM 8

181 - 200 = NOTHING

201 - 225 = MOTOR RESET

226 - 255 = NOTHING

Screw one clamp (3) via a M12 screw and nut to the included bracket (1). Attach the bracket using the provided screws to the bottom of the Stealth Wash Zoom. Attach the included eyehole screw (2) to the bottom of the fixture and pull the safety-cable through eyehole screw and over the trussing system or a safe fixation spot. Insert the end in the carabine and tighten the safety screw.

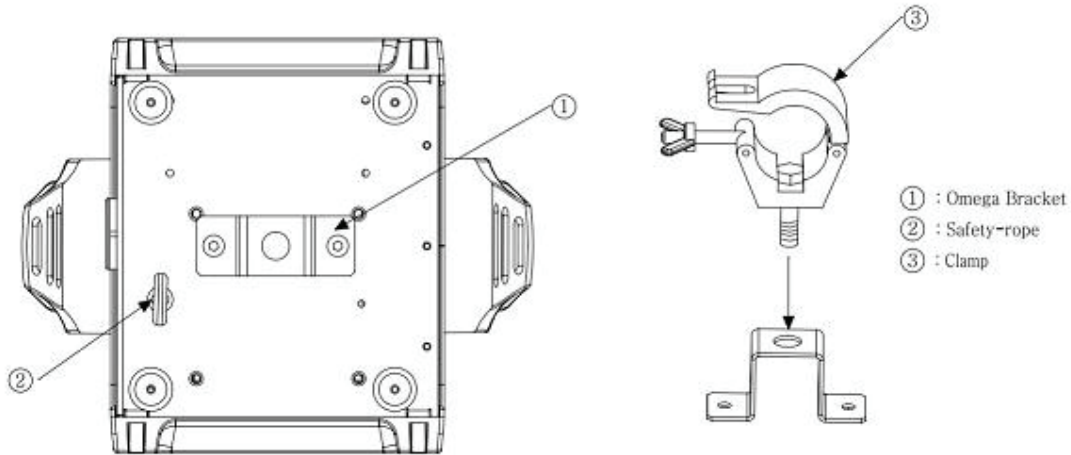

## Dimensional Drawings

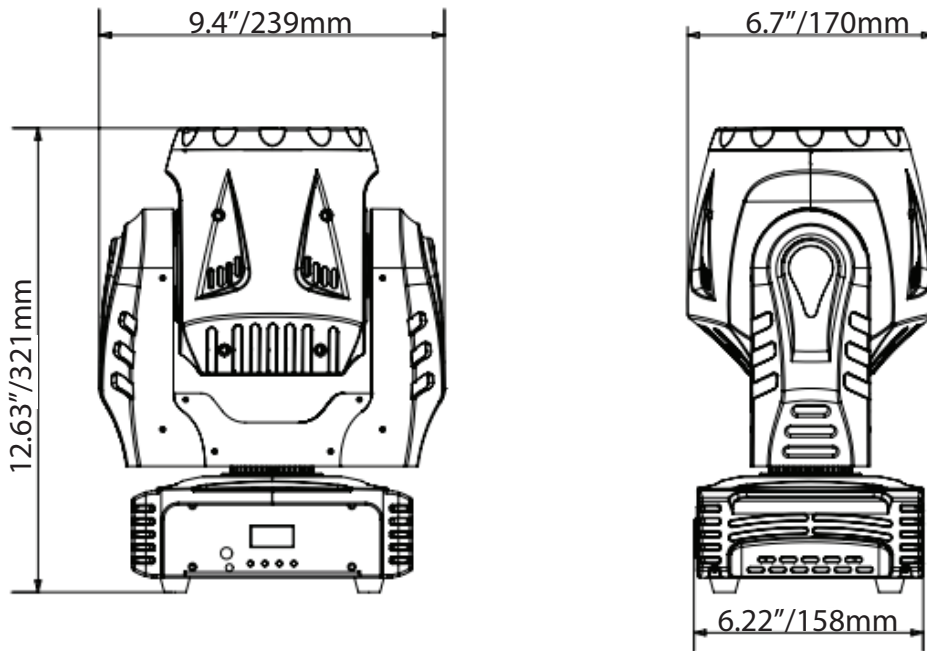

**1 Year Limited Warranty:** Eliminator Lighting warranty is valid from the date of purchase. Our 1 year limited warranty covers manufacturing defects only. Serial number, place of purchase with dated valid receipt must be submitted at time of service. Eliminator Lighting warranty does not cover items or parts prone to wear and tear: motors, fuses, brushes and belts. Eliminator Lighting warranty is only valid with-in the United States.