



Little Giant 5 112 Combo Guitar Amplifier

User's Guide



TABLE OF CONTENTS

Introduction	3
BH5-112 Special Features	4
The Front Panel	5
The Rear Panel	6
Important Information About Tubes and Tube Products	7
A Brief History of Tubes	7
Tube Types and Usage	7
The Nature of Tubes: Why (and When) to Replace Them	8
The Importance of Proper Biasing	9
Survival Tips for Tube Amplifiers	10
System Block Diagram	11
Technical Specifications	12
Service Information	12

	CAUTION RISK OF ELECTRIC SHOCK DO NOT OPEN	
<small>WARNING: TO REDUCE THE RISK OF FIRE OR ELECTRIC SHOCK, DO NOT EXPOSE THIS APPARATUS TO RAIN OR MOISTURE. TO REDUCE THE RISK OF ELECTRIC SHOCK, DO NOT REMOVE COVER. NO USER-SERVICEABLE PARTS INSIDE. REFER SERVICING TO QUALIFIED SERVICE PERSONNEL.</small>		

	PRECAUCION RIESGO DE CORRIENTAZO NO ABRA	
<small>PRECAUCION: PARA REDUCIR EL RIESGO DE INCENDIOS O DESCARGAS ELECTRICAS, NO PERMITA QUE ESTE APARATO QUEDE EXPUESTO A LA LLUVIA O LA HUMEDAD. PARA DISMINUIR EL RIESGO DE CORRIENTAZO NO ABRA LA CUBIERTA. NO HAY PIEZAS ADENTRO QUE EL USUARIO PUEDE REPARAR DEJE TODO MANTENIMIENTO A LOS TECNICOS CALIFICADOS.</small>		

	ATTENTION RISQUE D'ELECTROCUTION NE PAS OUVRIR	
<small>ATTENTION: PROTEGEZ CET APPAREIL DE LA PLUIE ET DE L'HUMIDITE AFIN D'EVITER TOUT RISQUE D'INCENDIE OU D'ELECTROCUTION. POUR REDUIRE D'ELECTROCUTION NE PAS ENLEVER LE COUVERCLE. AUCUNE PIECE INTERNE N'EST REPARABLE PAR L'UTILISATEUR. POUR TOUTE REPARATION, S'ADRESSER A UN TECHNICIEN QUALIFIE.</small>		

IMPORTANT SAFETY INSTRUCTIONS

- READ, FOLLOW, HEED, AND KEEP ALL INSTRUCTIONS AND WARNINGS.
- DO NOT OPERATE NEAR ANY HEAT SOURCE AND DO NOT BLOCK ANY VENTILATION OPENINGS ON THIS APPARATUS. FOR PROPER OPERATION, THIS UNIT REQUIRES 3" (75mm) OF WELL VENTILATED SPACE AROUND HEATSINKS AND OTHER AIR FLOW PROVISIONS IN THE CABINET.
- DO NOT USE THIS APPARATUS NEAR SPLASHING, FALLING, SPRAYING, OR STANDING LIQUIDS.
- CLEAN ONLY WITH LINT-FREE DAMP CLOTH AND DO NOT USE CLEANING AGENTS.
- ONLY CONNECT POWER CORD TO A POLARIZED, SAFETY GROUNDED OUTLET WIRED TO CURRENT ELECTRICAL CODES AND COMPATIBLE WITH VOLTAGE, POWER, AND FREQUENCY REQUIREMENTS STATED ON THE REAR PANEL OF THE APPARATUS.
- PROTECT THE POWER CORD FROM DAMAGE DUE TO BEING WALKED ON, PINCHED, OR STRAINED.
- UNPLUG THE APPARATUS DURING LIGHTNING STORMS OR WHEN UNUSED FOR LONG PERIODS OF TIME.
- THIS APPARATUS HAS BEEN DESIGNED WITH CLASS-I CONSTRUCTION AND MUST BE CONNECTED TO A MAINS SOCKET OUTLET WITH A PROTECTIVE EARTHING CONNECTION (THE THIRD GROUNDING PRONG).
- THIS APPARATUS HAS A DETACHABLE POWER CORD THAT IS CONNECTED TO THE IEC SOCKET ON THE REAR PANEL AND SHOULD REMAIN READILY ACCESSIBLE TO THE USER.
- THIS APPARATUS HAS BEEN EQUIPPED WITH A DOUBLE-POLE ROCKER-STYLE AC MAINS POWER SWITCH. THIS SWITCH IS LOCATED ON THE FRONT PANEL AND SHOULD REMAIN READILY ACCESSIBLE TO THE USER.
- ONLY USE ATTACHMENTS, ACCESSORIES, STANDS, OR BRACKETS SPECIFIED BY THE MANUFACTURER FOR SAFE OPERATION AND TO AVOID INJURY.
- WARNING: TO REDUCE THE RISK OF ELECTRIC SHOCK OR FIRE, DO NOT EXPOSE THIS UNIT TO RAIN OR MOISTURE.
- SERVICE MUST BE PERFORMED BY QUALIFIED PERSONNEL.
- OUR AMPLIFIERS ARE CAPABLE OF PRODUCING HIGH SOUND PRESSURE LEVELS. CONTINUED EXPOSURE TO HIGH SOUND PRESSURE LEVELS CAN CAUSE PERMANENT HEARING IMPAIRMENT OR LOSS. USER CAUTION IS ADVISED AND EAR PROTECTION IS RECOMMENDED IF UNIT IS OPERATED AT HIGH VOLUME.
- WARNING: THIS UNIT REQUIRES A SAFETY GROUNDED OUTLET WIRED TO CURRENT ELECTRIC CODES HAVING THE LINE SUPPLY VOLTAGE, POWER, AND FREQUENCY IDENTIFIED ON THE REAR OF THE UNIT. THE OUTLET MUST REMAIN ACCESSIBLE TO DISCONNECT THE UNIT IF A FAULT SHOULD ARISE WHILE IN USE. THIS UNIT SHOULD BE UNPLUGGED WHEN NOT IN USE.

EXPLANATION OF GRAPHICAL SYMBOLS:

EXPLICACION DE SIMBOLOS GRAFICOS:

EXPLICATION DES SYMBOLES GRAPHIQUES:



= "DANGEROUS VOLTAGE"

= "VOLTAJE PELIGROSO"

"DANGER HAUTE TENSION"



= "IT IS NECESSARY FOR THE USER TO REFER TO THE INSTRUCTION MANUAL"

= "ES NECESARIO QUE EL USUARIO SE REFIERA AL MANUAL DE INSTRUCCIONES."

"REFERREZ-VOUS AU MANUAL D'UTILISATION"



Introduction

Congratulations! You have just purchased what we believe to be one of the most significant objects that you'll acquire in your lifetime—a tube amp. If that's not enough, you've gone and gotten yourself a Blackheart Engineering tube amp. So let's take a big picture view of this for a second: You're a guitar player that could have bought anything to bring your mind-bending chops to life, to unleash upon the masses the wrath of your otherworldly, mad riffin' skills. Did you settle? No, because you're more than just "whatever." You're like, "hear me roar!" so you go tube. Not "hybrid," not "solid state," but all tube—from when you scream "jump!" until your speaker wails "how high sir!"

We like you. You've got style. Speaking of which, take a look at the way this amp is built. 16 gauge steel, ½" radius corners in a void-free birch ply cabinet that looks like Michelangelo covered it for you personally. How about double-sided PCB with 2 ounce copper tracers so your big fat sound has lots to hold on to traveling through a classic boutique circuit path designed by none other than Pyotr Belov himself. The guy's got a soldering iron in his hands most hours of the night so if he says make the thing like a tank, everyone agrees real quickly. Who knows, you might be in some sort of edge band; knock the thing around a bit. That's a Blackheart thing. We make rock-solid, no compromise music gear that sounds like choruses of angels that sing in big, beefy power chords. We work with glass, metal and wood just like the powers that be intended when they created rock and roll. We take every amp personally and we do it assuming you worked hard to get it and we're not letting you down. That fancy tattoo logo was inspired by one of our test animals.* He said a great amp leaves a permanent mark on your tone and shapes how you play, write, perform, etc. So, when you laid down coin for a Blackheart, you kind of got hitched.

And it didn't set you back much, especially when you consider what you got. Every Blackheart design starts as a hand-built masterpiece with no thoughts about cutting cost or going for it on the cheap. Pyotr picks every component one by one and tweaks until his ears hear the tone. Once he's given birth to the prototype (ouch!), he personally works with offshore manufacturing to translate that exact tone into the most affordable piece of gear that won't let you down. Literally, he works in the factory, training other people how to build boutique-quality amps and sits on the QC line before anything gets into a box. Blackheart isn't the cheapest—plenty of other amps are cheap and you can have your pick. We prefer to be ultra-high quality and performance for a price that anyone can afford.

So thanks for laying down your hard earned cash for a Blackheart Engineering product. We're not going to disappoint you. You've got, in your hands, one of the best sounding, best quality, old school inspired amps that's ever been made.

Vous avez notre coeur,

Pyotr Belov

Kevin Van Pamel

Walter Hsu

Blackheart Engineering

* We don't test on little furry helpless animals of course. We call our artists animals because, well, we've eaten with them. They give their time and opinions to us on a regular basis and have a lot to do with how good your Blackheart is.



BH5-112 Special Features:

- Single-ended Class A circuit
- All tube signal path
- One 12AX7/ECC83 dual-triode preamp tube and one EL84/6BQ5 pentode output tube
- Pentode (5W rms) Triode (3W rms) switch
- DC filament power supply for all tubes
- 3-band EQ
- 16-gauge (1.5 mm) thick, folded and spot welded steel chassis
- Double-sided custom color PCB with 2 oz. copper
- 15-ply, 18 mm thick, void-free birch plywood construction
- Custom-designed 12" Eminence Blackheart speaker
- 16 ohm, 8 ohm, and 4 ohm speaker outputs





The Front Panel

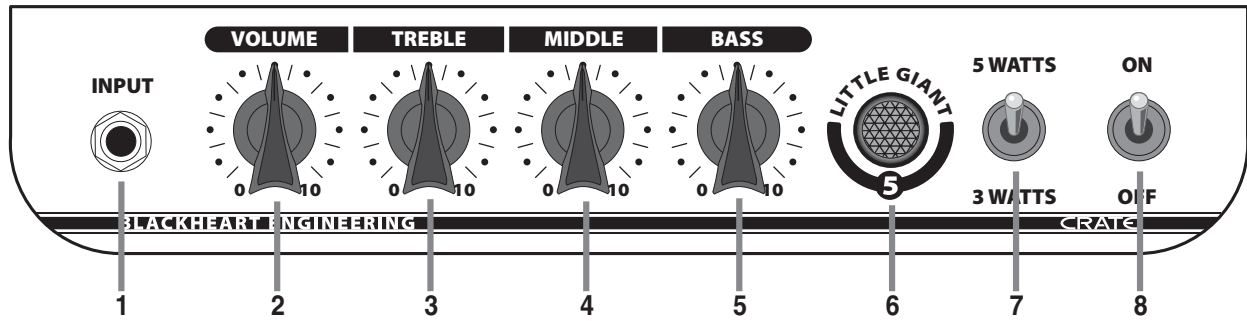

- 1. INPUT:** Use this jack to connect your guitar to the amplifier using a high-quality shielded instrument cable.
- 2. VOLUME:** Use this to adjust the output level.
- 3. TREBLE:** Use this to adjust the output level of the high frequencies. The adjustment range is 20 dB at 10 kHz.
- 4. MIDDLE:** Use this to adjust the output level of the mid frequencies. The adjustment range is 7 dB at 1 kHz.
- 5. BASS:** Use this to adjust the output level of the low frequencies. The adjustment range is 11 dB at 100 Hz.
- 6. Indicator Lamp:** This illuminates when the amplifier is turned on (power, that is).
- 7. 5 WATTS/3 WATTS:** This is the Pentode/Triode switch. It allows you to operate the amplifier in two distinct modes of operation and output power rating. The Pentode is the aggressive setting that gives you full output power of 5 watts rms. The Triode is a gentler setting with more head room that reduces the output power to 3 watts rms.
- 8. ON/OFF SWITCH:** Use this switch to turn the amplifier on and off.



The Rear Panel

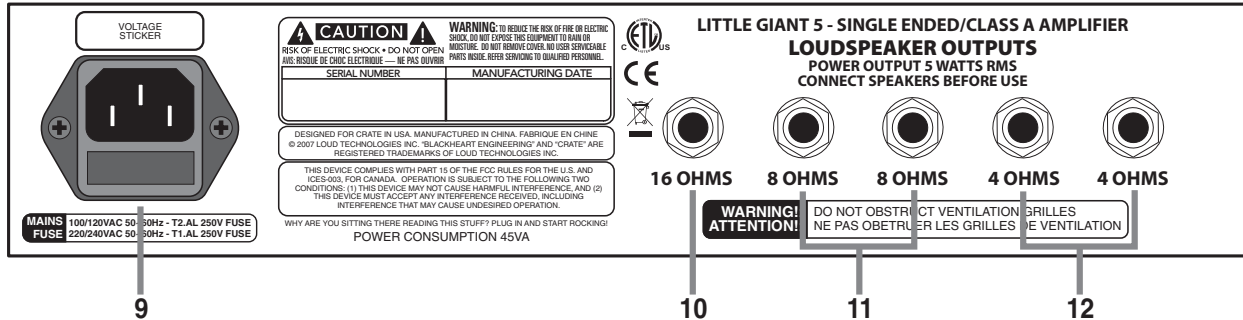

WARNING! Never turn on or use the amplifier without a load or speaker connected to the amplifier. **ALWAYS** use a good quality (non-shielded) speaker cable. Never use (shielded) instrument cable. **ALWAYS** match the amplifier's speaker output impedance to the impedance of the speaker that is being used. Use only one type impedance output at a time. If more than one speaker is connected at the same time, make sure they all have the same impedance rating. Never use two or more cabinets with different impedance ratings. This will create an unbalanced load. When using multiple speaker cabinets (with the same impedance rating), match the total load impedance of the speaker cabinets to the speaker output of the amplifier.

SPEAKER CABINET IMPEDANCE divided by NUMBER OF CABINETS = TOTAL LOAD

- 4 x 16 ohm cabinets with parallel inputs = 4 ohm load. For this application use 4 ohm output jacks.
- 2 x 16 ohm cabinets = 8 ohm load. For this application use the 8 ohm speaker jacks.
(If using the internal 16 ohm speaker with an external 16 ohm speaker, connect them both to the 8 ohm jacks.)
- 1 x 16 ohm cabinet = 16 ohm load. For this application use the 16 ohm speaker jack.
- 2 x 8 ohm cabinets = 4 ohm load. For this application use the 4 ohm output jacks.
- 1 x 8 ohm cabinet = 8 ohm load. For this application use the 8 ohm speaker jack.
- 1 x 4 ohm cabinet = 4 ohm load. For this application use the 4 ohm speaker jack.

9. AC Power Input with Mains Fuse

Assembly: Your amplifier is equipped with a detachable power cable that plugs into the IEC Mains socket of the amplifier (located inside the open hole in the back of the cabinet, towards the top). The AC power cord should only be plugged into a grounded power outlet that meets all applicable electrical codes and is compatible with the voltage, power, and frequency requirements stated on the rear panel of the amplifier. Do not attempt to defeat the safety ground connection. The AC Mains fuse is located in the IEC Mains socket and is used to protect the amplifier from electrical faults. If the fuse needs to be replaced, please refer to the correct fuse specifications located on the back panel of the amplifier. Never bypass the fuse or replace it with a wrong type or value.

10. **16 OHMS:** The 16 ohms speaker output jack is designated for 16 ohm speaker cabinets only. The Blackheart Little Giant 5 112 Combo is equipped with a Custom Designed

Eminence Speaker rated at 16 ohms. Be sure the combo's speaker is plugged into the 16 OHMS jack before the amp is turned on.

NOTE: Use the 8 OHMS and 4 OHMS speaker outputs if you want to use external speaker cabinets instead of the built-in 16 ohm Eminence speaker. **Unplug the built-in speaker when using the 8 OHMS or 4 OHMS speaker outputs.**

11. **8 OHMS:** The two 8 ohms speaker output jacks are wired in parallel. Use a single jack when using one 8 ohm speaker cabinet. Use both speaker jacks when using two 16 ohm speaker cabinets.
12. **4 OHMS:** The two 4 ohms speaker output jacks are wired in parallel. Use a single jack when using one 4 ohm speaker cabinet. Use both speaker jacks when using two 8 ohm speaker cabinets. If you have four 16 ohm cabinets with parallel speaker jacks (i.e., Blackheart 112 or 412 Cabinet), you can link all four 16 ohm cabinets in a parallel wiring configuration, totaling a 4 ohm load.



Important Information about Tubes and Tube Products:

A Brief History Of The Tube:

In 1883, Edison discovered that electrons would flow from a suspended filament when enclosed in an evacuated lamp. Years later, in 1905, Fleming expanded on Edison's discovery and created the "Fleming Valve." Then, in 1907, Dr. Lee de Forest added a third component – the grid – to the "Fleming Valve" and the vacuum tube was a fact of life. The door to electronic amplification was now open.

During World War II, data gleaned from their intensive research on the detectors used in radar systems, led Bell Telephone Laboratories to the invention of the transistor. This reliable little device gained quick support as the new component for amplification. The death of the vacuum tube seemed imminent as designers, scientists, and engineers reveled in the idea of replacing large, fragile glass tubes with these small, solid-state devices.

However, there were (and still are) many serious listeners who realized that the sound produced by a "transistor" amplifier is significantly different from that produced by a tube amplifier with identical design specifications. They considered the sound produced by these new solid-state devices to be hard, brittle, and lifeless. It was determined that solid-state devices produced a less musical set of harmonics than tubes. When pushed past their limits, they tend to mute the tone and emphasize the distortion.

Tubes, on the other hand, produce a more musical set of harmonics, the intensity of which can be controlled by the player. This characteristic adds warmth and definition to the sound which has become the hallmark of tube amplifiers. When tubes are driven into clipping, the harmonic overtones can be both sweet and pleasing or intense and penetrating, depending on the musician's musical taste and playing technique.

Over the years, application engineers have designed a number of outstanding solid-state amplifiers that sound very, very good. Some use special circuitry which enables them to simulate the distortion characteristics of a tube amplifier. However, the tube amplifier, still held in the highest esteem by many musicians, offers a classic "vintage" sound in a contemporary market.

Tube Types And Usage:

Tube amplifiers are based primarily on two types of tubes – preamplifier tubes and power tubes. The tubes used in preamplifiers (12AX7, 12AU7, 12AT7, etc.) are smaller than the power tubes. These tubes amplify the signal from your instrument and shape the sound. They are inherently microphonic (they can mechanically pick up and transmit external noises). Since these tubes are used in the critical first stages of a tube amplifier's circuitry, it is very important to use high-quality, low noise/low microphonic tubes for this application. Although tubes of this quality may be difficult to find and typically cost more than "off-the-shelf" tubes, the improvement in performance is worth the investment.

Preamplifier tubes are also used to drive the power tubes. When used in this application, a 12AX7 will produce a more distorted tone than a 12AT7, which produces a clearer, sweeter sound. A 12AU7 is even cleaner and brighter than a 12AT7, giving more definition to the sound. (In some cases it is possible to change the sound by changing the type of preamp and/or driver tubes. When making any modification to your equipment, it is highly recommended that you consult with a qualified service center.)



Important Information About Tubes and Tube Products (continued):

The power tubes are the largest tubes used in an amplifier. These tubes convert the low-level, conditioned signal from the preamplifier into a level that is sufficient to drive the speakers. There are several types of power tubes available, each of which offers a different performance/sound characteristic. For example, the EL34 power tube produces a great classic rock sound. When an EL34 is driven into distortion, it produces a unique sound (“crunch”). When compared to the 6L6, the EL34 distorts more quickly, exhibits a “looser” low-end response and produces more harmonics at mid and high frequencies (“creamier” sound). These differences become more noticeable at higher volumes.

The EL84 is similar to the EL34 but produces less output power. It can be easily driven into distortion and is characterized by a smooth, sweet tone with excellent touch sensitivity.

6L6 tubes produce a big low-end thump and have a very good dynamic range. They offer a more traditional “American Rock” sound. The 6V6 tubes produce a creamy sound with nice distortion. On the other hand, the KT88 produces a big low-end but sounds more like an EL34 in the mid and high frequencies.

6550 power tubes are more rugged and stay cleaner-sounding even at full power. When they do distort, the sound produced is more solid and has a tighter low end; more of a “heavy metal” type distortion with lots of power.

Some tubes are available in matched sets. These tubes have been extensively tested for optimum performance and longevity.

The Nature Of Tubes — Why (And When) To Replace Them:

Tubes are made up of a number of fragile mechanical components that are vacuum-sealed in a glass envelope or bubble. The tube’s longevity is based on a number of factors which include how hard and often the amplifier is played, vibration from the speakers, road travel, repeated set up and tear down, etc.

Any time you notice a change in your amplifier’s performance, check the tubes first.

If it’s been a while since the tubes were replaced and the sound from your amplifier lacks punch, fades in and out, loses highs or lows or produces unusual sounds, the power tubes probably need to be replaced. If your amplifier squeals, makes noise, loses gain, starts to hum, lacks “sensitivity”, or feels as if it is working against you, the preamplifier tubes may need to be replaced.

The power tubes are subjected to considerably more stress than the preamplifier tubes. Consequently, they almost always fail/degrade first. If deteriorating power tubes aren’t replaced they will ultimately fail. Depending on the failure mode, they may even cause severe damage to the audio output transformer and/or other components in the amplifier. Replacing the tubes before they fail completely has the potential to save you time, money and unwanted trouble. Since power tubes work together in an amplifier, it is crucial that they (if there is more than one) be replaced by a matched set. If you’re on the road a lot, we recommend that you carry a spare matched set of replacement power tubes and their associated driver tubes.

After turning off the power and disconnecting the amplifier from the power source, carefully check the tubes (in bright light) for cracks or white spots inside the glass or any other apparent damage. Then, with the power on, view the tubes in a dark room. Look for preamplifier tubes that do not glow at all or power tubes that glow excessively red.



Important Information About Tubes and Tube Products (continued):

Whenever you replace the power tube(s):

- Always have the amplifier's bias voltage checked by a qualified service center. Improper bias voltage will cause degradation in performance and possibly damage the tubes and/or the amplifier. (See "The Importance of Proper Biasing", below for more information).
- We highly recommend that you replace the driver tube(s) as well. The driver tube determines the shape and amplitude of the signal applied to the power tube(s) and has to work almost as hard as the power tube(s).

You can check your preamplifier tubes for microphonics by turning the amplifier on, turning up the gain and tapping lightly on each tube with the end of a pencil or a chop stick (my favorite). You will be able to hear the tapping through your speakers, which is normal. It is not normal for a tube to ring like a bell after it's tapped. If it does ring then it's microphonic and should be replaced. Remember to use only high quality, low microphonic tubes in the preamplifier section.

Even though power tubes are rarely microphonic, you should check them anyway. The power tubes can be checked for microphonics just like pre-amp tubes.

In the case of very high gain amps, you may be able to reduce the amount of noise generated by simply swapping the preamp tubes around.

The Importance Of Proper Biasing:

For the best performance and longest tube life, proper biasing is imperative. Bias is the negative voltage which is applied to the power tube's control grid to set the level of idle current. We cannot over emphasize the difference in warmth of tone and dynamic response that come with proper biasing. If the bias is set too high (over biased), the sound from the amp will be distorted at all levels. If the bias is set too low, (under biased) the power tubes will run hot (the plates inside the tubes may glow red due to excessive heat) and the sound from the amplifier will lack power and punch. The excessive heat greatly reduces tube life – from a few days to as little as a few hours in extreme cases. Setting the bias on your amp is like setting the idle on your car. If it's too high or hot it's running away with you and if it's too low or cold it will choke when you step on it.

The bias is adjusted at the factory in accordance with the type of power tube(s) installed in your amplifier. It is important to point out that tubes of the same type and specification typically exhibit different performance characteristics. Consequently, whenever power tubes are replaced, the bias voltage must be checked (unless the amplifier is equipped with "self-biasing" circuitry) and readjusted to accommodate the operating parameters of the replacement tubes.

Depending on the model and amplifier type, there may be hum balance controls, trim pots, or bias adjustment controls on its rear panel. However, the bias adjustment should be performed only by qualified service personnel with the proper, calibrated test equipment.



Important Information About Tubes and Tube Products (continued):

Survival Tips For Tube Amplifiers:

To prolong tube life, observe these tips and recommendations:

- Match the impedance of your speaker cabinet(s) to your amplifier. Improper impedance matching will contribute to early tube degradation and may cause premature tube failure.
- Make sure the speaker(s) are properly connected prior to turning on the amplifier.
- After playing the amplifier, allow sufficient time for it to properly cool down prior to moving it. A properly cooled amplifier prolongs tube life due to the internal components being less susceptible to the damage caused by vibration.
- Allow the amplifier to warm up to room temperature before turning it on. The heat generated by the tube elements can crack a cold glass housing.
- Replace the output tube(s) before the performance degrades or the tubes fail completely. Replace the tube(s) on a regular basis (at least once per year or as often as every 4 to 6 months if you play long and hard every day).
- Always have the bias checked after replacing the output tubes (unless the amplifier is equipped with “selfbiasing circuitry”). This should be done **ONLY** at a qualified service center. Improper biasing could result in the tubes running too hot, which greatly reduces the life of the tubes – or too cold, which results in distorted sound regardless of level settings. Do not play the amplifier if it exhibits these symptoms – get the bias checked/adjusted immediately to prevent tube failure and/or other damage.
- If the locating notch on the base of a power tube breaks off, replace the tube. This significantly reduces the risk of damaging your amplifier by incorrectly inserting the tube.
- Protect the amplifier from dust and moisture. If liquid gets into the amplifier proper, or if the amplifier is dropped or otherwise mechanically abused, have it checked out at an authorized service center before using it.
- Proper maintenance and cleaning in combination with routine checkups by your authorized service center will insure the best performance and longest life from your amplifier.

CAUTION: Tube replacement should be performed only by qualified service personnel who are familiar with the dangers of hazardous voltages that are typically present in tube circuitry.



System Block Diagram

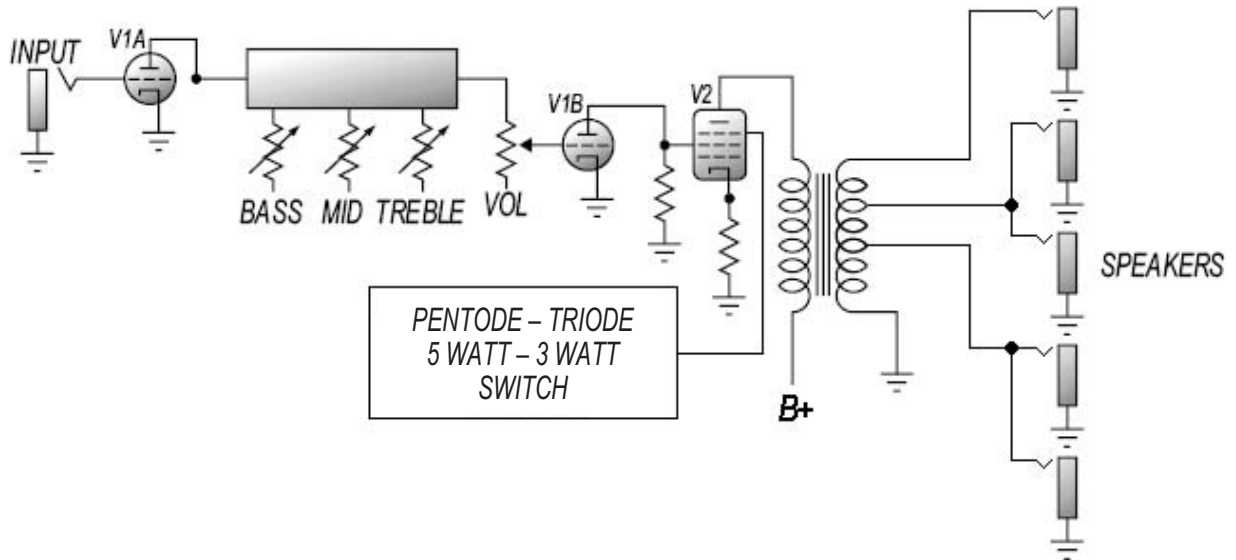

Declaration Of Conformity

Manufacturer:

LOUD Technologies Inc.
16220 Wood-Red Rd. NE
Woodinville, WA 98072, USA

Product Name:

Blackheart BH5-112

Product Type:

Audio Amplifier

Complies with Standards:

LVD:

92/31/EEC, 93/68/EEC, & 73/23/EWG

Safety:

EN60065

EMC:

EN55013, EN55020, EN55022, EN55103, EN61000-3-2,
& EN61000-3-3

The official Declaration of Conformity for this product is kept on file at:
LOUD Technologies Inc., 16220 Wood-Red Road NE, Woodinville, WA 98072 • Tel: 1-866-858-5832



BH5-112 TECHNICAL SPECIFICATIONS

Output Power Rating	Pentode: 5 W rms @ 22% THD, 16 ohm load Triode: 3 W rms @ 9% THD, 16 ohm load
Signal-to-Noise Ratio	63 dB, Typical
Input Impedance	1 Meg Ohm
EQ	Treble: 20 dB range @ 10 kHz Middle: 7 dB range @ 1 kHz Bass: 11 dB range @ 100 Hz
Preamp Tube	1 x 12AX7/ECC83
Power Tube	1 x EL84/6BQ5
Rectifier	Solid State
Speaker Specs	Custom Designed Eminence Blackheart Speaker Model 1216A, American Voiced, 12", 75 W, 16 ohm, 1.75" voice coil diameter, 34 oz magnet
Speaker Outputs	1 x 16 ohms 2 x 8 ohms (8 ohms total load impedance required) 2 x 4 ohms (4 ohms total load impedance required)
Power Requirements	110/120 VAC, 50/60 Hz, 45 VA 220/240 VAC, 50/60 Hz, 45 VA
AC Mains Fuse	100/120 VAC: T2.AL 250V Fuse 220/240 VAC: T1.AL 250V Fuse
Size (H x W x D)	18.6 in/473 mm (including feet) x 18.0 in/460 mm x 11.0 in/280 mm
Weight	38.6 lb/17.5 kg

The Blackheart Little Giant 5 112 Combo is covered with a durable fabric-backed vinyl material. Wipe it clean with a lint-free cloth. Never spray cleaning agents onto the cabinet. Avoid abrasive cleansers which would damage the finish.

Crate continually develops new products, as well as improves existing ones. For this reason, the specifications and information in this manual are subject to change without notice.

"Blackheart" and "Crate" are registered trademarks of LOUD Technologies Inc. All other brand names mentioned are trademarks or registered trademarks of their respective holders and are hereby acknowledged.

Service Information

If you are having a problem with your Blackheart Little Giant 5 112 Combo Guitar Amplifier, you can go to our website (www.blackhearteng.com) and click on "Heart Surgery" for service information, or call 1-800-898-3211 during business hours (7 am to 5 pm PST, Monday-Friday). If you are outside of the U.S., contact your local distributor for technical support and service.

**BLACKHEART ENGINEERING
AMPLIFIER SERIES**

www.blackhearteng.com

@2007 LOUD Technologies Inc.

16220 Wood-Red Road NE • Woodinville, WA 98072

Part No. 0027865 Rev. A1 10/07

