

ATTCO HYBRID 230

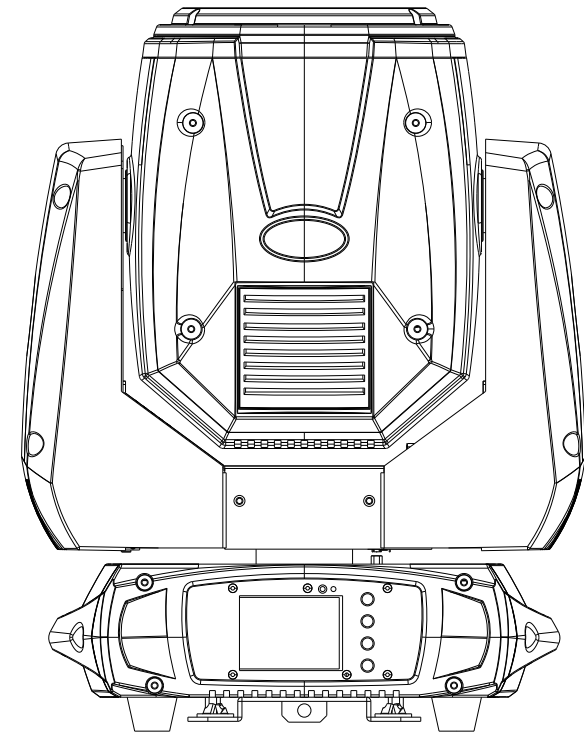

Version 1.0



JMAZ LIGHTING

Address: 313 NEWQUIST PLACE STE B, CITY OF INDUSTRY, CA 91745 USA
Phone: 1-626-380-0883 www.jmazlighting.com support@jmazlighting.com

USER MANUAL

- Be sure to read the USER MANUAL carefully before using this product.
- Be sure to keep the USER MANUAL properly for future needs.
- Use this product correctly when you can fully understand the User Manual

1.Safety instructions

Thank you for choosing our ATTCO HYBRID 230. For your own safety, please read this user manual carefully

BEFORE YOU INITIAL START - UP!

CAUTION!
Be careful with your operations.
With a high voltage you can suffer a dangerous electric shock when touching the wires!

This device has left our premises in absolutely perfect condition. In order to maintain this condition and to ensure a safe operation, it is absolutely necessary for the user to follow the safety instructions and warning notes written in this manual.

CAUTION!
Keep this device away from rain and moisture!
Unplug mains lead before opening the housing!

Important:

The manufacturer will not accept liability for any resulting damages caused by the non-observance of this manual or any unauthorized modification to the device.

Please consider that damages caused by manual modifications to the device are not subject to warranty.

During the operation the housing becomes hot). Allow the fixture to cool approximately 20 minutes prior to manipulate with it.

Make sure that the available voltage is not higher than stated on the rear panel.

WARNING! This unit does not contain an ON/OFF switch. Always disconnect power input cable to completely remove power from unit when not in use or before cleaning or servicing the fixture.

Make sure that the power-cord is never crimped or damaged by sharp edges. Check the device and the power-cord from time to time.

Always disconnect from the mains, when the device is not in use or before cleaning it. Only handle the power-cord by the plug. Never pull out the plug by tugging the power cord.

This device falls under protection class I. Therefore it is essential to connect the yellow/green conductor to earth.

The electric connection, repairs and servicing must be carried out by a qualified employee.

Do not connect this device to a dimmer pack.

Do not switch the fixture on and off in short intervals as this would reduce the lamp's life.

During the initial start-up some smoke or smell may arise. This is a normal process and does not necessarily mean that the device is defective.

Do not touch the device's housing bare hands during its operation (housing becomes hot)!

For replacement use lamps and fuses of same type and rating only.

CAUTION ! EYE DAMAGES !
Avoid looking directly into the light source
(meant especially for epileptics) !

11.Maintenance and cleaning

It is absolutely essential that the fixture is kept clean and that dust, dirt and smoke-fluid residues must not build up on or within the fixture. Otherwise, the fixture's light-output will be significantly reduced. Regular cleaning will not only ensure the maximum light-output, but will also allow the fixture to function reliably throughout its life. A soft lint-free cloth moistened with any good glass cleaning fluid is recommended, under no circumstances should alcohol or solvents be used!

DANGER !
Disconnect from the mains before starting any
maintenance work

The front objective lens will require weekly cleaning as smoke-fluid tends to building up residues, reducing the light-output very quickly. The cooling-fans should be cleaned monthly.

The interior of the fixture should be cleaned at least annually using a vacuum-cleaner or an air-jet. Remove dust and dirt from the fans and cooling vents using a soft brush and vacuum-cleaner.

Important! Check the air filters periodically and clean before they become clogged!

Clean two air filters placed in the fixture's covers and two in the fixture base. Use a vacuum cleaner, compressed air or you can wash them and put back dry.

After replacing the air filters, reset the elapsed time counter in the menu "Information" (Information--->Air Filters--->Elapsed Time).

Replacing the fuse. Before replacing the fuse, unplug mains lead.

- 1) Remove the fuse holder on the rear panel of the base with a fitting screwdriver from the housing (anti-clockwise).
- 2) Remove the old fuse from the fuse holder.
- 3) Install the new fuse in the fuse holder (only the same type and rating).
- 4) Replace the fuseholder in the housing and fix it.

9	9	0-255	In(near) to Out(far)
10	10		Rotating prism 1
		0-5	Prism 1 swing out(hole)
		6-127	Prism 1 swing in
		128-189	Prism 1 Forwards rotation from fast to slow
		190-193	Prism 1 rotation stop
		194-255	Prism 1 Backwards rotation from slow to fast
11	11		Rotating prism 2
		0-5	Prism 2 swing out(hole)
		6-127	Prism 2 swing in
		128-189	Prism 2 Forwards rotation from fast to slow
		190-193	Prism 2 rotation stop
		194-255	Prism 2 Backwards rotation from slow to fast
12	12		Frost
		0-199	Frost swing out
		200-255	Frost swing in
13	13		Speed pan/tilt
		0-225	Max to min speed
		226-235	Block out by movement
		236-245	Blackout by all wheel changing
		246-255	No function
14	14		Special function
		0-19	No function
		20-29	No function
		30-39	No function
		40-59	Lamp on
		60-79	Lamp switch off
		80-84	Total Reset
		85-87	Pan/Tilt Reset
		88-90	Color Reset
		91-93	Gobo Reset
		94-96	Strobe Reset
		97-99	The Others Reset
		100-119	Internal program 1
		120-139	Internal program 2
		140-159	Internal program 3
		160-179	Internal program 4
		180-199	Internal program 5
		200-219	Internal program 6
		220-239	Internal program 7
		240-255	Internal program 8
	15		Color Time
		0-255	Max to min speed
	16		Gobo Time
		0-255	Max to min speed

2.UNPACKING

The ATTCO HYBRID 230 adopts a 231W lamp which features high brightness and stability. Please carefully unpack it when you receive the fixture and check whether it is damaged during the transportation. And please check whether the following items are included inside the box:

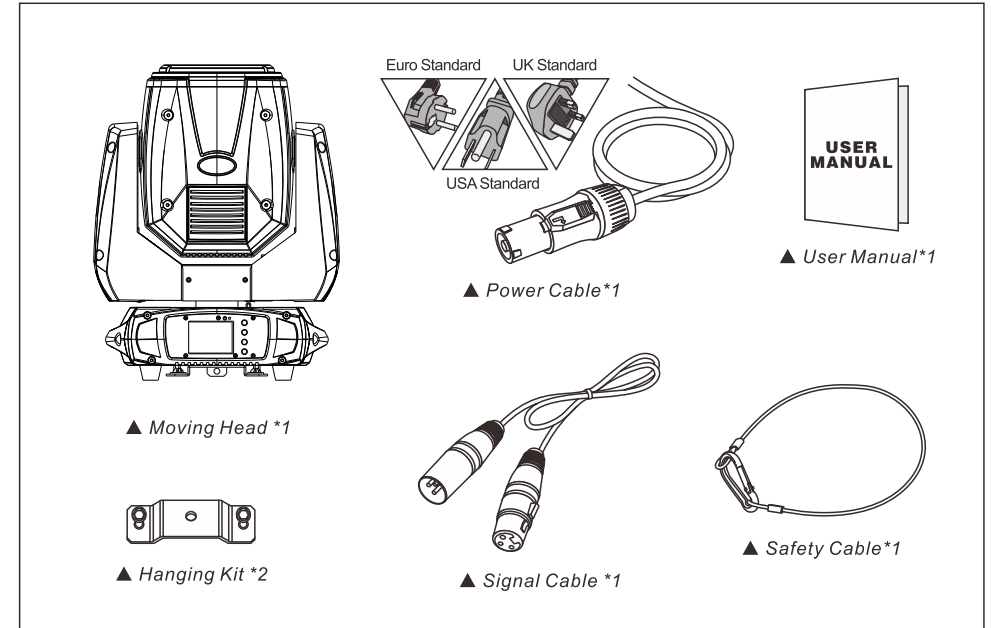

The ATTCO HYBRID 230 is made of a new type of high temperature strength of engineering plastics and cast aluminum casing with nice outlook . The fixture is designed and manufactured strictly following CE standards, complying with international standard DMX512 protocol. It's available independently controlled and linkable with each other for operation. And it is applicable for large-scale live performances, theater, studio, nightclubs and discos.

This manual covers the important information on installation and applications. Meanwhile, please keep this manual well for future needs.

3. TECHNICAL INFORMATION

SPECIFICATIONS:

- 1X OSRAM SIRIUS HRI 231W Lamp
- 2000 Hours rated lamp source
- Input voltage: AC90-260V 50/60Hz
- Power consumption: 310W
- Control signal: DMX512, master-slave and sound activated or auto operation (8 built-in programs)
- Control channel: 14/16 DMX channels USITT DMX-512
- Dimensions: 12"x 8.8"x 17" / 30.7*22.4*43.5cm
- Packing dimensions: 17"x 10"x 20" / 44*26.5*51.5cm
- Net weight: 28.16 lbs. / 12.8kgs
- Gross weight: 34 lbs. / 15.6kgs

FEATURES:

- 2.5° Beam angle
- Anti-reflection 136mm front lenses
- Motorized focus from near to far (2.5M-30M)
- Dual prism wheel, 8-facet prism + 24-facet prism with variable speed
- 8 Built-in lighting shows
- Built-in wireless DMX technology
- Frost filter available (Hybrid effect for wash)
- Dual flag mechanical dimming system
- 20T/sec high speed LED shutter/strobe effect with variable speed
- Preset variable/random strobe and dimming pulse effect
- 2.4" TFT LCD display (320*240pix)
- Display reversible for up side down application
- Powercon IN/OUT
- 3-Pin XLR connectors IN/OUT
- Lamp using time readable on the display
- IP20 protection rating
- 55dB at 3'dB rating
- 2*1/4 turn fastening Omega clamps
- 1* Safety attachment point available

MOVEMENT:

- Smooth and precise resolution for PAN/TILT movement 630° / 540° / 360° PAN and 270° / 180° / 90° TILT movement optional

- Scan position memory, auto reposition after unexpected movement

COLORS:

- 1 Color wheel with 11 colors plus open.

GOBOS:

- 1 Static gobo wheel with 16 gobos plus open

FUNCTION:

- Electronic ballast and power supply
- Improved optics and flat beam field
- No need for adjustment of reflector or lamp
- Variable direction rainbow effect with speed adjustable
- Vector mode with blackout MIB function
- Constant temperature readout and management function
- Fan cooling system
- -35-45°C max ambient temperature

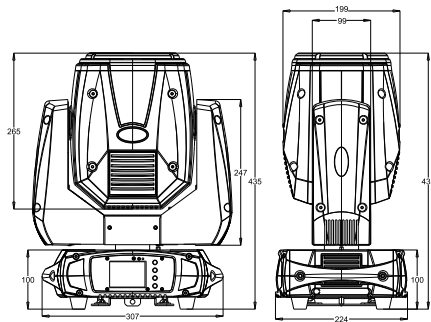

Static Gobo Wheel



Color Wheel

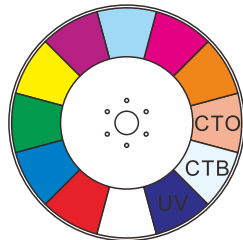

		15-19	gobo 3
		20-24	gobo 4
		25-29	gobo 5
		30-34	gobo 6
		35-39	gobo 7
		40-44	gobo 8
		45-49	gobo 9
		50-54	gobo 10
		55-59	gobo 11
		60-64	gobo 12
		65-69	gobo 13
		70-74	gobo 14
		75-79	gobo 15
		80-84	gobo 16
		85-92	Gobo 1 shake slow to fast
		93-100	Gobo 2 shake slow to fast
		101-107	Gobo 3 shake slow to fast
		108-116	Gobo 4 shake slow to fast
		117-124	Gobo 5 shake slow to fast
		125-132	Gobo 6 shake slow to fast
		133-140	Gobo 7 shake slow to fast
		141-148	Gobo 8 shake slow to fast
		149-156	Gobo 9 shake slow to fast
		157-164	Gobo 10 shake slow to fast
		165-172	Gobo 11 shake slow to fast
		173-180	Gobo 12 shake slow to fast
		181-188	Gobo 13 shake slow to fast
		189-196	Gobo 14 shake slow to fast
		197-204	Gobo 15 shake slow to fast
		205-212	Gobo 16 shake slow to fast
		213-255	Rot. gobo wheel cont. rotation slow to fast
7	7		Shutter
		0-31	Shutter closed
		32-63	Shutter open
		64-95	Strobe effect slow to fast
		96-127	Shutter open
		128-143	Opening pulse in sequences slow to fast
		144-159	Closing pulse in sequences fast to slow
		160-191	Shutter open
		192-223	Random strobe effect slow to fast
		224-255	Shutter open
8	8		Dimmer
		0-255	Dimmer 0%...100%
9	9		Focus

10.DMX PROTOCOL

Mode/Channel		Values	Function
Standard	Vector		
1	1		Pan
		0-255	PAN Movement
2	2		Pan-fine
		0-255	Fine control of Pan movement
3	3		Tilt
		0-255	Tilt Movement
4	4		Tilt-fine
		0-255	Fine control of Tilt movement
5	5		Color wheel
		0-4	Open / white
		5-9	White+Color 1
		10-14	Color 1
		15-19	Color 1+Color 2
		20-24	Color 2
		25-29	Color 2+Color 3
		30-34	Color 3
		35-39	Color 3+Color 4
		40-44	Color 4
		45-49	Color 4+Color 5
		50-54	Color 5
		55-59	Color 5+Color 6
		60-64	Color 6
		65-69	Color 6+Color 7
		70-74	Color 7
		75-79	Color 7+Color 8
		80-84	Color 8
		85-89	Color 8+Color 9
		90-94	Color 9
		95-99	Color 9+Color 10
		100-104	Color 10
		105-109	Color 10+Color 11
		110-114	Color 11
		115-127	Color 11+White
		128-189	Forwards rainbow effect from fast to slow
		190-193	Color rotation stop
		194-255	Backwards rainbow effect from slow to fast
6	6		Gobo Wheel 1
		0-4	Open
		5-9	gobo1
		10-14	gobo 2

4.PHOTOMETRICS DIAGRAM

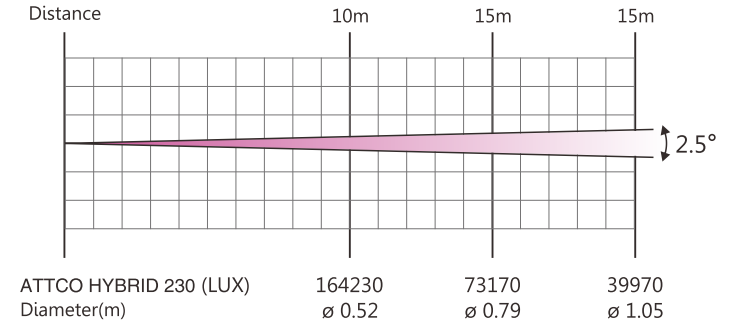

5.OPERATION INSTRUCTIONS

- The ATTCO HYBRID 230 is for beam effect for on-site decoration purpose.
- Don't turn on the fixture if it's been through severe temperature difference like after transportation because it might damage the light due to the environment changes. So make sure to operate the fixture until it is in normal temperature.
- This light should be keep away from strong shaking during any transportation or movement.
- Don't pull up the light by only the head, or it might cause damages to the mechanical parts.
- Don't expose the fixture in overheat, moisture or environment with too much dust when installing it. And
- don't lay any power cables on the floor. Or it might cause electronic shock to the people.
- Make sure the installation place is in good safety condition before installing the fixture.
- Make sure to put the safety chain and check whether the screws are screwed properly when installing the fixture.
- Make sure the lens are in good condition. It's recommended to replace the units if there are any damages or severe scratch.
- Make sure the fixture is operated by qualified personnel who knows the fixture before using.
- Keep the original packages if any second shipment is needed.
- Don't try to change the fixtures without any instruction by the manufacturer or the appointed repairing agencies.
- It is not in warranty range if there are any malfunctions from not following the user manual to operate or any illegal operation, like shock short circuit, electronic shock, lamp broke, etc.

6.INSTALLATIONS

Cautions:

For added protection mount the fixtures in areas outside walking paths, seating areas, or in areas where the fixture might be reached by unauthorized personnel.

Before mounting the fixture to any surface, make sure that the installation area can hold a minimum point load of 10 times the device's weight.

Fixture installation must always be secured with a secondary safety attachment, such as an appropriate safety cable.

Never stand directly below the device when mounting, removing, or servicing the fixture.

from a ceiling, or set on a flat level surface (see illustration below). Be sure this fixture is kept at least 0.5m (1.5 f t) away from any flammable materials (decoration etc.).

Always use and install the supplied safety cable as a safety measure to prevent accidental damage and/or injury in the event the clamp fails.

Mounting points:

Overhead mounting requires extensive experience, including amongst others calculating working load limits, a fine knowledge of the installation material being used, and periodic safety inspection of all installation material and the fixture. If you lack these qualifications, do not attempt the installation yourself. Improper installation can result in bodily injury.

Be sure to complete all rigging and installation procedures before connecting the main power cord to the appropriate wall outlet.

Clamp Mounting:

ATTCO HYBRID 230 provides a unique mounting bracket assembly that integrates the bottom of the base, and the safety cable rigging point in one unit (see the illustration below). When mounting this fixture to truss be sure to secure an appropriately rated clamp to the included omega bracket using a M10 screw fitted through the center hole of the "Hanging Kit". As an added safety measure be sure to attached at least one properly rated safety cable to the fixture using one of the safety cable rigging points integrated in the base assembly .

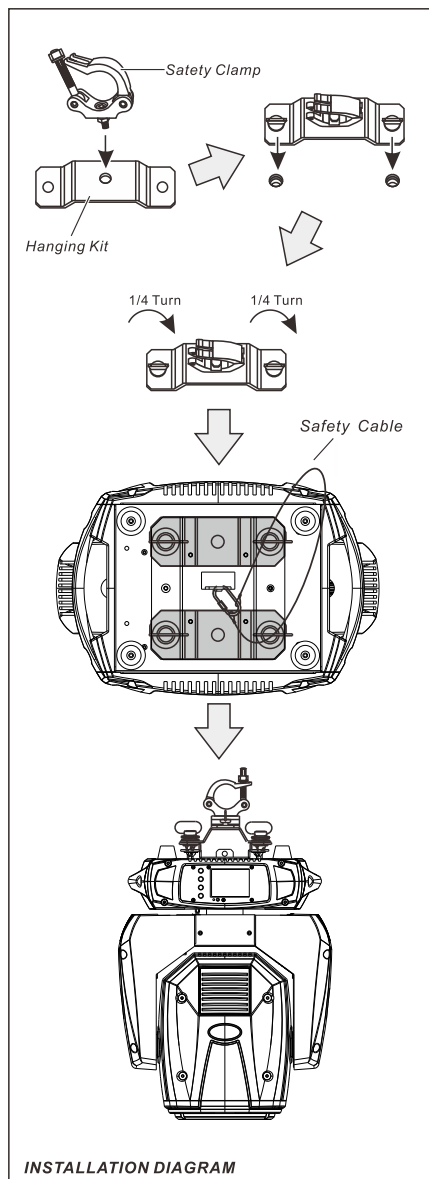

Description of the Wireless Indicator for Wireless DMX

1. Under the Set-up mode, each color on the indicator means different communication protocols:

1. Red ----- WIDMX Protocol
2. Green ----- WDMX Receive Protocol
3. Blue ----- WDMX Transmit Protocol
4. Yellow ----- (Generic) Protocol

2. Under the Operation mode, explanation of the indicator's status:

Protocol	Action	Status Description
WIDMX or Generic Protocol	Red, Green, Blue, Yellow, Cyan, Purple, (White)	Different Wireless Groups
	Flashing Red	Transmitting Wireless DMX Signal
	Flashing Green	Receiving Wireless DMX Signal
WDMX Receive Protocol	White	Connection is not
	Red	Deleting Connection
	Red(Fast-Flash)	Connection is Lost
	Green(Fast-Flash)	Connecting to Transmitter
	Green(Slow-Flash)	Connected, Without DMX Signal
WDMX Transmit Protocol	Green	Connected, Receiving DMX Signal
	Red	Deleting all Receivers'
	Blue(Fast-Flash)	Connecting with the Receiver(s)
	Blue(Slow-Flash)	No DMX Signal Input
	Blue	Transmitting DMX

9. Operation Guide for the Wireless DMX

How to Set-up the Wireless DMX Mode:

Turn the power switch to off on the back of the light, press and hold the "SELECT" button then turn the power switch to ON. When you see status indicator turns into the white color, release the button to enter the Set-up mode. In this mode you can select different transmission protocols. Each time you press the "SELECT" button, you would see the status indicator changes in following order: red, green, blue and yellow. Choose one of the protocols (**recommended using RED- WIDMX protocol**), then press and hold the "SELECT" button for two seconds, when you see the indicator light turns to white color, release the "SELECT" button and it will enter the operation mode, the set up for wireless DMX is done.

* Under the WIDMX protocol or Generic protocol, you can select different DMX Group:

Press the "SELECT" button once, it will indicated the current DMX group. Press the "SELECT" button twice, you can switch over to different DMX group.

* Under the WDMX Transmit protocol:

1. By pressing the "SELECT" button once, the transmitter will try to connect all of the receivers within the coverage area
2. Press and hold the "SELECT" button for more than three seconds, the indicator will turn to red. The device will delete all the receivers' connection within the coverage range.
3. In WDMX Receive protocol:
Press and hold the "SELECT" button for more than three seconds until the indicator turns white. The device would delete the current connection setting with the transmitter.

Explanation of the DMX Signal setting on the menu

Options:	Function:
Wire DMX	Using wire DMX signal input
Wireless DMX	Using Wireless DMX signal input
Act WDMX & Out	Using Wireless DMX signal input, at the same time, it will send out DMX signal to the DMX output on the back of the light
WIDMX Out	Using wire DMX signal input, at the same time, it will send out wireless DMX signal through the wireless transmitter. (In case if there is no wire DMX input signal, the device will stay at Wireless DMX receiving mode)

7. CONTROL CONNECTION

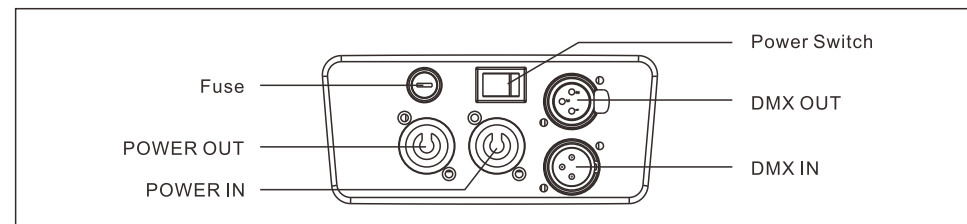

Connect the provided XLR cable to the female 3-pin XLR output of your controller and the other side to the male 3-pin XLR input of the moving head. You can chain multiple Moving head together through serial linking. The cable needed should be two core, screened cable with XLR input and output connectors. Please refer to the diagram below. DMX-512 connection with DMX terminator.

For installations where the DMX cable has to run a long distance or is in an electrically noisy environment, such as in a discotheque, it is recommended to use a DMX terminator. This helps in preventing corruption of the digital control signal by electrical noise. The DMX terminator is simply an XLR plug with a 3 resistor connected between pins 2 and 3, which is then plugged into the output XLR socket of the last fixture in the chain. Please see illustrations below.

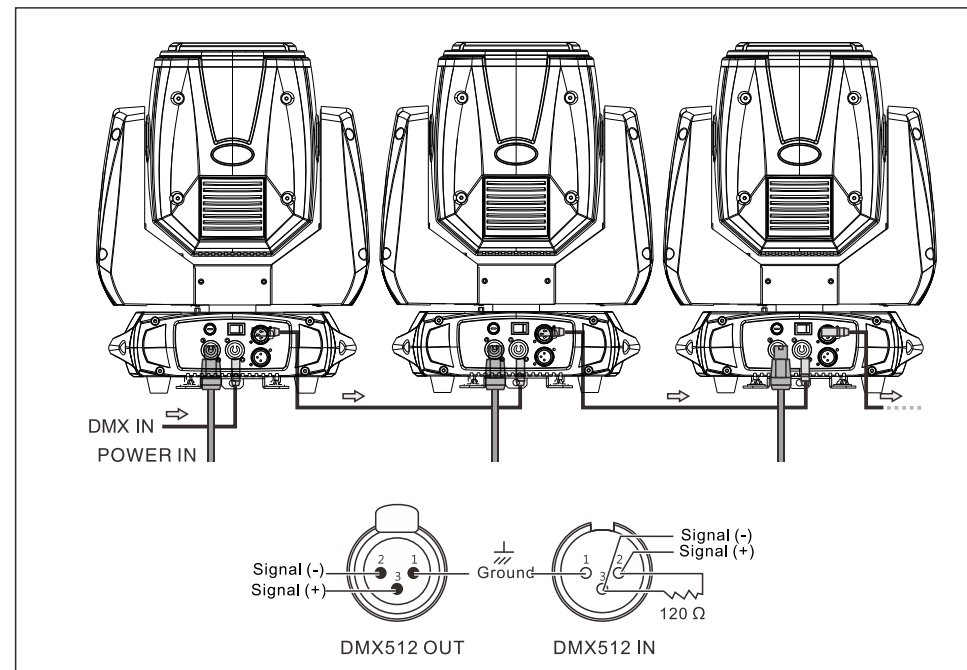

8.MENU OPERATIONS

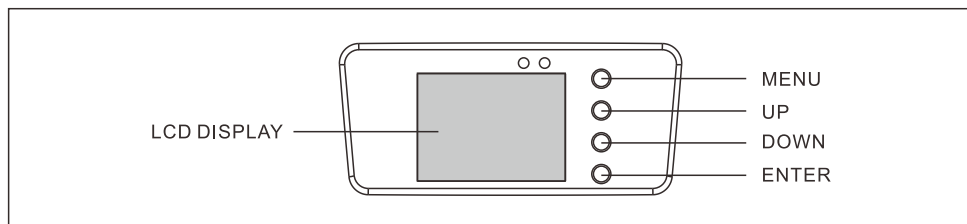

MENU		Description
Function Mode	Dmx Address	A001~AXXX DMX address setting
	Channel Mode	CH14 MODE Standard mode
		CH16 MODE Vector mode
	Auto Run	Internal Program1~8 Auto run
State: Master/Alone State: Master/Alone		
Auto Run (On/Off) Auto Run (On/Off)		
Music Control	Internal Program1~8 Sound Control	
	State: Master/Alone State: Master/Alone	
	Music Run (On/Off) Music Run (On/Off)	
Option	Reset Default	Yes/No Reset Default
	Signal Set	Wire DMX Wire DMX
		Wireless DMX Wireless DMX
		Act WDMX & Out Act WDMX & Out
		WiDMX Out WiDMX Out
	Pan / Tilt	Reverse Pan (On/Off) Reverse Pan
		Reverse Tilt (On/Off) Reverse Tilt
		Select Pan 540°/360°/630° Pan Degree, default is 540°
	UI SET	Select Tilt 270°/90°/180° Tilt Degree, default is 270°
		Mic SEN 0~99% MIC Sensitivity Setting
		OFF Signal Mode (On/Off) OFF at original status and ON at reset status when no DMX signal
		Half Color Wheel(On/Off) Default ON
Start Up Lamp(On/Off) Default ON		
Fan Protect(On/Off) Default ON		
Information	Lamp Hours	XXXX(Hours) Lamp Hours
	Temperature	XXX°C/°F Current Temperature
	Software Version	V1.0~V9.9 Software Version
	Fan Parameter	Current = xxx mA Voltage = xxx mV Lamp Fan Parameter

Manual Control	Lamp	On/Off	Lamp ON/OFF
		Total Reset	Total Reset
		Pan/Tilt Reset	Pan/Tilt Reset
		Color Reset	Color Reset
		Gobo Reset	Gobo Reset
		Strobe Reset	Strobe Reset
Channel	The Others Reset	The Others Reset	
	PAN=XXX.....	Channel Control	
Advanced (Access Code 088)	Calibration	PAN=XXX.....	Calibration
	Clear Lamp Time	Yes/No	Clear Lamp Time