

American DJ®

MEGA BAR LED RC



User Instructions

American DJ®
6122 S. Eastern Ave.
Los Angeles Ca. 90040
www.americandj.com

Mega Bar LED RC

Introduction

Unpacking: Thank you for purchasing the Mega Bar LED RC by American DJ®. Every Mega Bar LED RC has been thoroughly tested and has been shipped in perfect operating condition. Carefully check the shipping carton for damage that may have occurred during shipping. If the carton appears to be damaged, carefully inspect your fixture for any damage and be sure all accessories necessary to operate the unit has arrived intact. In the case damage has been found or parts are missing, please contact our toll free customer support number for further instructions. Do not return this unit to your dealer without first contacting customer support.

Introduction: The Mega Bar LED RC is part of American DJ's continuing pursuit for creating high quality affordable intelligent fixtures. The Mega Bar LED RC is a DMX intelligent LED color wash. This wash can be used in a stand alone mode or connected in a Master/Slave configuration. The unit can also be controlled via DMX controller. This wash has four operating modes: Sound Active mode, Auto mode, Program mode, and DMX control mode.

Customer Support: American DJ® provides a toll free customer support line, to provide set up help and to answer any question should you encounter problems during your set up or initial operation. You may also visit us on the web at www.americandj.com for any comments or suggestions. Service Hours are Monday through Friday 9:00 a.m. to 5:00 p.m. Pacific Standard Time.

Voice: (800) 322-6337

Fax: (323) 582-2941

E-mail: support@americandj.com

To purchase parts online visit <http://parts.americandj.com>

Warning! To prevent or reduce the risk of electrical shock or fire, do not expose this unit to rain or moisture.

Caution! There are no user serviceable parts inside this unit. Do not attempt any repairs yourself, doing so will void your manufactures warranty. In the unlikely event your unit may require service please contact American DJ®.

PLEASE recycle the shipping carton when ever possible.

Mega Bar LED RC

General Instructions

To optimize the performance of this product, please read these operating instructions carefully to familiarize yourself with the basic operations of this unit. These instructions contain important safety information regarding the use and maintenance of this unit. Please keep this manual with the unit, for future reference.

Mega Bar LED RC

Features

- Multicolor
- Color Strobe
- Electronic Dimming 0-100%
- Built in Microphone
- DMX-512 protocol
- 6 DMX Channel Modes: 2, 3, 4, 6, 7, or 11 DMX Channels

Mega Bar LED RC

Warranty Registration

The Mega Bar LED RC carries a 3 year (1095 days) limited warranty. Please fill out the enclosed warranty card to validate your purchase and warranty. You may also register your product online at www.americandj.com. All returned service items whether under warranty or not, must be freight pre-paid and accompany a return authorization (R.A.) number. If the unit is under warranty you must provide a copy of your proof of purchase invoice. Please contact American DJ® customer support for a R.A. number.

Mega Bar LED RC

Cleaning

Due to fog residue, smoke, and dust cleaning the internal and external optical lenses must be carried out periodically to optimize light output.

1. Use normal glass cleaner and a soft cloth to wipe down the outside casing.
2. Clean the external optics with glass cleaner and a soft cloth every 20 days.
3. Always be sure to dry all parts completely before plugging the unit back in.

Cleaning frequency depends on the environment in which the fixture operates (i.e. smoke, fog residue, dust, dew).

Mega Bar LED RC

Safety Precautions

- To reduce the risk of electrical shock or fire, do not expose this unit to rain or moisture
- Do not spill water or other liquids into or on to your unit.
- Be sure that the local power outlet matches that of the required voltage for your unit.
- Do not attempt to operate this unit if the power cord has been frayed or broken. Do not attempt to remove or break off the ground prong from the electrical cord. This prong is used to reduce the risk of electrical shock and fire in case of an internal short.
- Disconnect from main power before making any type of connection.
- Do not remove the cover under any conditions. There are no user serviceable parts inside.
- Never operate this unit when its cover is removed.
- Never plug this unit into a dimmer pack
- Always be sure to mount this unit in an area that will allow proper ventilation. Allow about 6" (15cm) between this device and a wall.
- Do not attempt to operate this unit, if it becomes damaged.
- This unit is intended for indoor use only, use of this product outdoors voids all warranties.
- During long periods of non-use, disconnect the unit's main power.
- Always mount this unit in a safe and stable manner.
- Power-supply cords should be routed so that they are not likely to be walked on or pinched by items placed upon or against them, paying particular attention to the point they exit from the unit.
- Cleaning -The fixture should be cleaned only as recommended by the manufacturer. See page 3 for cleaning details.
- Heat -The appliance should be situated away from heat sources such as radiators, heat registers, stoves, or other appliances (including amplifiers) that produce heat.
- The fixture should be serviced by qualified service personnel when:
 - A. The power-supply cord or the plug has been damaged.
 - B. Objects have fallen, or liquid has been spilled into the appliance.
 - C. The appliance has been exposed to rain or water.
 - D. The appliance does not appear to operate normally or exhibits a marked change in performance.

Power Supply: The American DJ® Mega Bar LED RC contains an electronic ballast, which will auto sense the voltage when it is plugged into the power source. With the electronic power supply unit you do not need to worry about wall voltage, this unit can be plugged in anywhere.

DMX-512: DMX is short for Digital Multiplex. This is a universal protocol used as a form of communication between intelligent fixtures and controllers. A DMX controller sends DMX data instructions from the controller to the fixture. DMX data is sent as serial data that travels from fixture to fixture via the DATA “IN” and DATA “OUT” XLR terminals located on all DMX fixtures (most controllers only have a DATA “OUT” terminal).

DMX Linking: DMX is a language allowing all makes and models of different manufactures to be linked together and operate from a single controller, as long as all fixtures and the controller are DMX compliant. To ensure proper DMX data transmission, when using several DMX fixtures try to use the shortest cable path possible. The order in which fixtures are connected in a DMX line does not influence the DMX addressing. For example; a fixture assigned a DMX address of 1 may be placed anywhere in a DMX line, at the beginning, at the end, or anywhere in the middle. When a fixture is assigned a DMX address of 1, the DMX controller knows to send DATA assigned to address 1 to that unit, no matter where it is located in the DMX chain.

Data Cable (DMX Cable) Requirements (For DMX Operation):

The Mega Bar LED RC can be controlled via DMX-512 protocol. The Mega Bar LED RC can be a two, three, four, six, seven or 11 channel DMX unit. The DMX address is set on the back panel of the Mega Bar LED RC. Your unit and your DMX controller require a approved DMX-512 110 Ohm Data cable for data input and data output (Figure 1). We recommend Accu-Cable DMX cables. If you are making your own cables, be sure to use standard 110-120 Ohm shielded cable (This cable may be purchased at almost all professional sound and lighting stores). Your cables should be made with a male and female XLR connector on either end of the cable. Also remember that DMX cable must be daisy chained and cannot be split.



Figure 1

Notice: Be sure to follow figures two and three when making your own cables. Do not use the ground lug on the XLR connector. Do not connect the cable’s shield conductor to the ground lug or allow the shield conductor to come in contact with the XLR’s outer casing. Grounding the shield could cause a short circuit and erratic behavior.

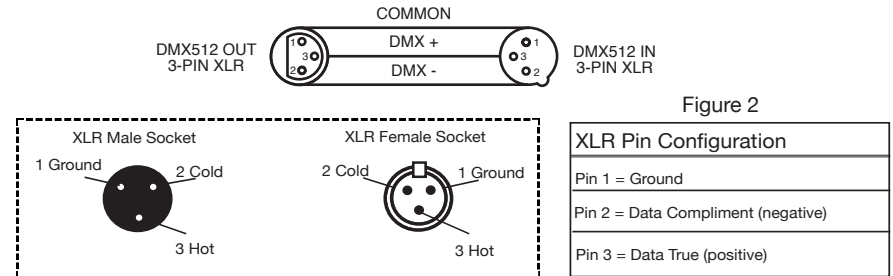

Figure 3

Special Note: Line Termination. When longer runs of cable are used, you may need to use a terminator on the last unit to avoid erratic behavior. A terminator is a 110-120 ohm 1/4 watt resistor which is connected between pins 2 and 3 of a male XLR connector (DATA + and DATA -). This unit is inserted in the female XLR connector of the last unit in your daisy chain to terminate the line. Using a cable terminator (ADJ part number Z-DMX/T) will decrease the possibilities of erratic behavior.



Termination reduces signal errors and avoids signal transmission problems and interference. It is always advisable to connect a DMX terminal, (Resistance 120 Ohm 1/4 W) between PIN 2 (DMX-) and PIN 3 (DMX +) of the last fixture.

Figure 4

5-Pin XLR DMX Connectors. Some manufactures use 5-pin XLR connectors for DATA transmission in place of 3-pin. 5-pin XLR fixtures may be implemented in a 3-pin XLR DMX line. When inserting standard 5-pin XLR connectors in to a 3-pin line a cable adaptor must be used, these adaptors are readily available at most electric stores. The chart below details a proper cable conversion.

Conductor	3-Pin XLR Female (Out)	5-Pin XLR Male (In)
Ground/Shield	Pin 1	Pin 1
Data Compliment (- signal)	Pin 2	Pin 2
Data True (+ signal)	Pin 3	Pin 3
Not Used		Do Not Use
Not Used		Do Not Use

LED Display On/Off: To make the display stay ON all of the time press the MODE and UP buttons at the same time. To make the display turn OFF after 20 seconds, press the MODE and DOWN buttons at the same time.

Operating Modes:

You can use the Mega Bar LED RC in either a stand alone mode or a master/slave configuration, there are 4 modes to choose from:

- Programs Mode - Select one of 16 different programs and adjust the speed and flash rate of the program.
- Auto Mode - The unit will automatically chase through the different programs.
- Sound-Active mode - The unit will react to sound, chasing through the built in programs.
- DMX control mode - This function will allow you to control each individual fixtures traits with a standard DMX 512 controller such as the Elation® Show Designer™.

Master-Slave Operation:

This function will allows you to link units together to run in a Master-Slave mode. In Master-Slave operation one unit will act as the controlling unit and the others will react to the controlling units built-in programs. Any unit can act as a Master or as a Slave however, only one unit can be programmed to act as the “Master.”

Master-Slave Connections and Settings:

1. Daisy chain your units via the XLR connector on the rear of the unit. Use standard XLR microphone cables to link your units together. Remember that the Male XLR connector is the input and the Female XLR connector is the output. The first unit in the chain (master) will use the female XLR connector only. The last unit in the chain will use the male XLR connector only. **Note: You can also daisy chain the power cords, this can only be done with 40 fixtures. After 40 you will need to use a new power outlet. They must be the same fixtures. DO NOT mix fixtures.**
2. You will also have to link the power cords to each other, as you did with the XLR cables.
3. Using the Master unit, choose your desired mode or program and

connect the “Slave” unit or units.

4. On the “Slave” unit(s) press the MODE button until “SLAV” is displayed. They will now follow the “Master” unit.

Programs Mode:

There are 16 programs to choose from.

Notes: Programs 1-7 are “Static” so you can only adjust the Flash Rate. Programs 8-11 you can adjust the Speed of the program and the Flash Rate. Program 12 you can adjust the Speed, Flash Rate, and the Color. Program 13 you can adjust the Speed, Flash Rate, and First Color and Second Color of the Color Flow. Programs 14-15 you can only adjust the Speed and Fade Time. Program 16 you can adjust the Speed, Fade Time, and First Color and Second Color of the Color Flow.

1. Plug the fixture in and press the MODE button until “PR.XX” is displayed. When “PR.XX” is displayed you are in Program mode.
2. Select your desired program in by pressing either the UP or DOWN buttons. There are 16 programs to choose from.
3. After you have selected your desired program, press the SETUP button to adjust the different features the program has. **Please see above to understand what program features can be adjusted.**

FEATURES AND ADJUSTMENTS

- When “SP.XX” is displayed you are adjusting the speed of the program. Use the UP or DOWN buttons to adjust. The speed can be adjusted from “SP.01” the slowest, to “SP.99” the fastest. Press the SETUP button when you are finished, to either go to the next feature adjustment or to exit to the Program menu. **NOTE: This adjustment is only available with Programs 8-16.**
- When “FS.XX” is displayed you are adjusting the flash rate of the program. Use the UP or DOWN buttons to adjust. The flash rate can be adjusted from “FS.01” the slowest, to “FS.99” the fastest. Press the SETUP button when you are finished, to either go to the next feature adjustment or to exit to the Program menu. **NOTE: This adjustment is available with Programs 1-13.**
- When “CL.XX” is displayed you are adjusting the colors of the program. Use the UP or DOWN buttons to adjust. The colors can be adjusted from “CL.01” to “CL.07”. Scroll through the colors to find your desired color. Press the SETUP button when you are finished,

to either go to the next feature adjustment or to exit to the Program menu. **NOTE: This adjustment is only available with Program 12.**

- When “C1.XX” is displayed you are adjusting the first color of the color flow. Use the UP or DOWN buttons to adjust. The colors can be adjusted from “C1.00” to “C1.07”. Scroll through the colors to find your desired color. Press the SETUP button when you are finished, to go to the next feature adjustment. “C2.XX” will be displayed you are now adjusting the second color of the color flow. Use the UP or DOWN buttons to adjust. The colors can be adjusted from “C2.00” to “C2.07”. Scroll through the colors to find your desired color. Press the SETUP button when you are finished, to exit to the Program menu. **NOTE: This adjustment is only available with Programs 13 & 16.**
- When “FT.XX” is displayed you are adjusting the fade time of the program. Use the UP or DOWN buttons to adjust. The fade time can be adjusted from “FT.01” the slowest, to “FT.99” the fastest. Press the SETUP button when you are finished, to exit to the Program menu. **NOTE: This adjustment is only available with Programs 14-16.**

Auto Mode:

1. Plug the fixture in and press the MODE button until “AUTO” is displayed. You are now in AUTO mode and the fixture will now cycle through the 13 built in programs.

Sound Active Mode:

In this mode the Mega Bar LED RC will react to sound, and chase through the different colors.

1. Plug the fixture in and press the MODE button until “SA.XX” is displayed. The fixture will now change color via sound.
2. You can press the UP or DOWN buttons to adjust the sound sensitivity level. The flash rate can be adjusted from “SA.00” the least sensitive, to “SA.31” the most sensitive.

DMX Mode:

There are six DMX Modes to choose from: 2 Channels, 3 Channels, 4 Channels, 6 Channels, 7 Channels, or 11 Channels. Operating through a DMX controller give the user the freedom to create their own programs tailored to their own individual needs.

1. This function will allow you to control each individual fixture’s traits with a Elation® DMX 512.
2. To run your fixture in DMX mode, plug in the fixture via the XLR connections to any standard DMX controller.
3. Press the MODE button until “d.XXX” is displayed. Press the UP or DOWN buttons to select your desired address. Once you have set your desired DMX address press the SETUP button to choose your desired DMX mode.
4. When you press the SETUP button “D-PX” should be displayed. Press the UP or DOWN buttons to select your desired DMX mode. The Modes go as follows: **“D-P1” is 3 Channel mode, “D-P2” is 4 Channel mode, “D-P3” is 11 Channel mode, “D-P4” is 2 Channel mode, “D-P5” is 6 Channel mode, and “D-P6” is 7 Channel mode.**
5. Please see pages 13-17 for DMX values and traits.

With this feature you can connect the fixtures to one another using the IEC input and output sockets. The quantity that can be connected is 40 fixtures maximum. After 40 fixtures you will need to use a new power outlet. They must be the same fixtures. DO NOT mix fixtures.

The **ADJ LED RC** infrared remote has many different functions and gives you complete control of your Mega Bar LED RC. To control the your desired fixture you must aim the controller at the front of the fixture and be no more the 30 feet away.

BLACKOUT - Pressing this button will blackout the fixture.

AUTO RUN - This button will run an automatic program. You can control the speed of the Auto Run by pressing the SPEED button first and then pressing the “+” and “-” buttons.

PROGRAM SELECTION - This button will let you access the units built-in programs. Pressing this button and then press the “+” or “-” to navigate through the built-in programs.

FLASH - This button will activate the strobe effect. You can control the flash rate by pressing the “+” and “-” buttons. Press this button again to exit strobe mode.

SPEED - Press this button and use the “+” & “-” buttons to adjust the speed of the Auto run.

DMX MODE - This button will let you select which DMX mode you want to use. Some fixtures will come with different DMX channel modes. This button will switch between the different modes. Please see pages 9-12 for DMX modes, values, and traits.

SOUND ACTIVE - This button activates sound active mode.

SLAVE - This designates the fixture as a slave fixture in a master/slave configuration.

SET ADDRESS - Press this button to set the DMX address. Press this button first, then press the numbers to set the address.

Example: DMX Address 1 Press “S001”

DMX Address 245 Press “S245”

R G B - Press either one of these buttons and then press the “+” or “-” to adjust the brightness.

“+” and “-” - Use these buttons to adjust the flash rate, speed of the Auto Run, sound sensitivity, and program selection.

DMX Control:

Operating through an Elation® DMX controller gives the user the freedom to create their own programs tailored to their own individual needs. Follow the directions below to set your DMX Mode and address.

1. Before connecting to an Elation® DMX controller, your fixture has different DMX channel modes, please select your desired mode by pressing the DMX Mode button, then using the “+” or “-” buttons to scroll through the DMX Channel Modes. Set the mode before you address the fixture. See the bottom of this page for the DMX modes.

2. After you have selected your mode, set the DMX address for the fixture by pressing the “S” button. When the “S” button is pressed the LED’s will flash 2-3 times and all the red LED’s will light. Use the number buttons to press in your desired address. See **“SET ADDRESS”** on page 11 for examples.

Note: When setting the DMX address each time a number is pressed a LED color will glow, when you have set the DMX address correctly all LED’s will flash 2-3 times.

3. Now you may connect the fixture via the XLR connections to any standard Elation® DMX controller. Please see pages 13-17 for a detailed descriptions of the DMX modes, values, and traits.

• **If one section of Red LED’s glow you are in DMX Mode 1: 3 DMX Channels**

• **If two section’s of Red LED’s glow you are in DMX Mode 2: 4 DMX Channels**

• **If all of the Red LED’s glow you are in DMX Mode 3: 11 DMX Channels**

• **If one section of Green LED’s glow you are in DMX Mode 4: 2 DMX Channels**

• **If two section’s of Green LED’s glow you are in DMX Mode 5: 6 DMX Channels**

• **If all of the Green LED’s glow you are in DMX Mode 6: 7 DMX Channels**

Mega Bar LED RC DMX Values and Traits - 3 Channels		
Channel	Value	Function
1	0 - 255	RED 0% - 100%
2	0 - 255	GREEN 0% - 100%
3	0 - 255	BLUE 0% - 100%

Mega Bar LED RC DMX Values and Traits - 4 Channels		
Channel	Value	Function
1	0 - 255	RED 0% - 100%
2	0 - 255	GREEN 0% - 100%
3	0 - 255	BLUE 0% - 100%
4	0 - 255	DIMMER CONTROL 0% - 100%

Mega Bar LED RC DMX Values and Traits - 11 Channels		
Channel	Value	Function
1	0 - 255	RED 1 0% - 100%
2	0 - 255	GREEN 1 0% - 100%
3	0 - 255	BLUE 1 0% - 100%
4	0 - 255	RED 2 0% - 100%
5	0 - 255	GREEN 2 0% - 100%
6	0 - 255	BLUE 2 0% - 100%
7	0 - 255	RED 3 0% - 100%
8	0 - 255	GREEN 3 0% - 100%
9	0 - 255	BLUE 3 0% - 100%
10	0 - 2 3 - 255	STROBE OFF SLOW - FAST
11	0 1 - 255	DIMMER OFF 0% - 100%

Mega Bar LED RC		DMX Values and Traits - 2 Channels
Channel	Value	Function
1		<u>MACROS/PROGRAMS</u>
	0 - 14	OFF
	15 - 28	RED
	29 - 42	YELLOW
	43 - 56	GREEN
	57 - 70	CYAN
	71 - 84	BLUE
	85 - 98	PURPLE
	99 - 112	WHITE
	113 - 126	COLOR CHANGE
	127 - 140	COLOR FLOW
	141 - 154	COLOR DREAM
	155 - 168	MULTI COLOR
	169 - 182	DREAM FLOW
	183 - 196	2 COLOR FLOW
	197 - 210	COLOR CHANGE FADE
	211 - 224	COLOR FLOW FADE
225 - 238	2 COLOR FLOW FADE	
239 - 255	SOUND ACTIVE	
2		SPEED/SOUND SENSITIVITY CONTROL
	0 - 255	SLOW - FAST

When the Channel 1 fader level is between the values of 113 and 238, the Channel 2 fader will control the speed of the macro/program.

When the Channel 1 fader is between 239 and 255 (Sound Active) the Channel 2 fader will control the sound sensitivity level. Channel 2 will start at least sensitive to most sensitive.

Mega Bar LED RC		DMX Values and Traits - 6 Channels
Channel	Value	Function
1	0 - 255	RED 0% - 100%
2	0 - 255	GREEN 0% - 100%
3	0 - 255	BLUE 0% - 100%
4		<u>MACROS/PROGRAMS</u>
	0 - 14	OFF
	15 - 28	RED
	29 - 42	YELLOW
	43 - 56	GREEN
	57 - 70	CYAN
	71 - 84	BLUE
	85 - 98	PURPLE
	99 - 112	WHITE
	113 - 126	COLOR CHANGE
	127 - 140	COLOR FLOW
	141 - 154	COLOR DREAM
	155 - 168	MULTI COLOR
	169 - 182	DREAM FLOW
	183 - 196	2 COLOR FLOW
	197 - 210	COLOR CHANGE FADE
	211 - 224	COLOR FLOW FADE
225 - 238	2 COLOR FLOW FADE	
239 - 255	SOUND ACTIVE	
5		<u>STROBING</u>
	0 - 15 16 - 255	NOTHING STROBE SLOW - FAST
6		<u>DIMMER</u>
	0 - 31	NOTHING
	32 - 63	DIM - BRIGHT
	64 - 95	BRIGHT - DIM
	96 - 127	DIM - BRIGHT - DIM
	128 - 159	COLOR MIXING
	160 - 191	3 COLOR CHANGING
	192 - 223	7 COLOR CHANGING
	224 - 255	SOUND ACTIVE

Mega Bar LED RC DMX Values and Traits - 7 Channels		
Channel	Value	Function
1	0 - 255	RED 0% - 100%
2	0 - 255	GREEN 0% - 100%
3	0 - 255	BLUE 0% - 100%
4		<u>MACROS/PROGRAMS</u>
	0 - 14	OFF
	15 - 28	RED
	29 - 42	YELLOW
	43 - 56	GREEN
	57 - 70	CYAN
	71 - 84	BLUE
	85 - 98	PURPLE
	99 - 112	WHITE
	113 - 126	COLOR CHANGE
	127 - 140	COLOR FLOW
	141 - 154	COLOR DREAM
	155 - 168	MULTI COLOR
	169 - 182	DREAM FLOW
	183 - 196	2 COLOR FLOW
	197 - 210	COLOR CHANGE FADE
211 - 224	COLOR FLOW FADE	
225 - 238	2 COLOR FLOW FADE	
239 - 255	SOUND ACTIVE	
5		<u>SPEED/SOUND SENSITIVITY CONTROL*</u>
	0 - 255	SLOW - FAST
6		<u>STROBE</u>
	0 1 - 255	OFF SLOW - FAST
7		<u>DIMMER</u>
	0 1 - 255	OFF 0% - 100%

*When the Channel 4 fader level is between the values of 113 and 238, the Channel 5 fader will control the speed of the macro/program.

When the Channel 4 fader is between 239 and 255 (Sound Active) the Channel 5 fader will control the sound sensitivity level. Channel 5 will start at least sensitive to most sensitive.

Mega Bar LED RC Fuse Replacement

Locate and remove the unit's power cord. Once the cord has been removed locate the fuse holder located inside the power socket. Insert a flat-head screw driver into the power socket and gently pry out the fuse holder. Remove the bad fuse and replace with a new one. The fuse holder has a built-in socket for a spare fuse be sure not to confuse the spare fuse with active fuse.

Mega Bar LED RC Trouble Shooting

Listed below are a few common problems the user may encounter, with solutions.

Unit not responding to DMX:

1. Check that the DMX cables are connected properly and are wired correctly (pin 3 is "hot"; on some other DMX devices pin 2 may be 'hot'). Also, check that all cables are connected to the right connectors; it does matter which way the inputs and outputs are connected.

Unit does not respond to sound:

1. Quiet or high pitched sounds will not activate the unit.

*If problems are not resolved; Contact American DJ® for service.
1-800-322-6337*

Mega Bar LED RC

Photometric Charts

Red

R 380 — 182 — 84 — 47 — 28 — 20 lux

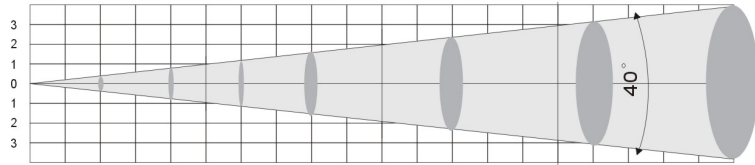

1.64'	3.28'	6.56'	9.84'	13.11'	16.39'	Distance(Feet)
0.5	1	2	3	4	5	Distance(Meters)
2.38'	4.76'	9.51'	14.27'	18.04'	23.79'	Diameter(Feet)

Mega Bar LED RC

Photometric Charts

Blue

B 757 — 412 — 185 — 104 — 65 — 43 lux

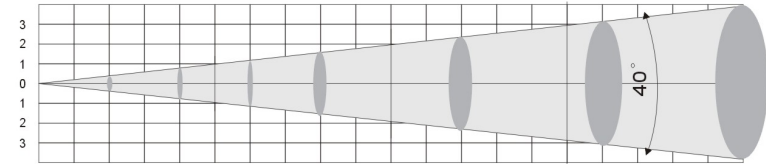

1.64'	3.28'	6.56'	9.84'	13.11'	16.39'	Distance(Feet)
0.5	1	2	3	4	5	Distance(Meters)
2.38'	4.76'	9.51'	14.27'	18.04'	23.79'	Diameter(Feet)

Green

G 980 — 540 — 250 — 143 — 85 — 54 lux

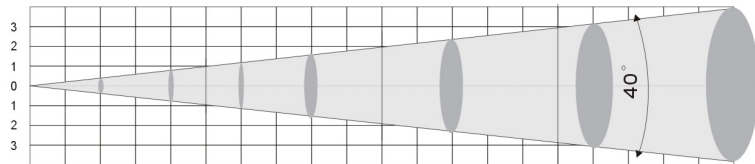

1.64'	3.28'	6.56'	9.84'	13.11'	16.39'	Distance(Feet)
0.5	1	2	3	4	5	Distance(Meters)
2.38'	4.76'	9.51'	14.27'	18.04'	23.79'	Diameter(Feet)

RGB Full On

RGB 2060 — 1085 — 518 — 294 — 185 — 121 lux

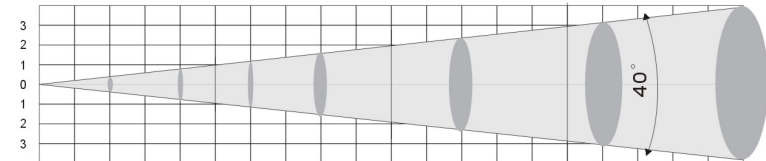

1.64'	3.28'	6.56'	9.84'	13.11'	16.39'	Distance(Feet)
0.5	1	2	3	4	5	Distance(Meters)
2.38'	4.76'	9.51'	14.27'	18.04'	23.79'	Diameter(Feet)

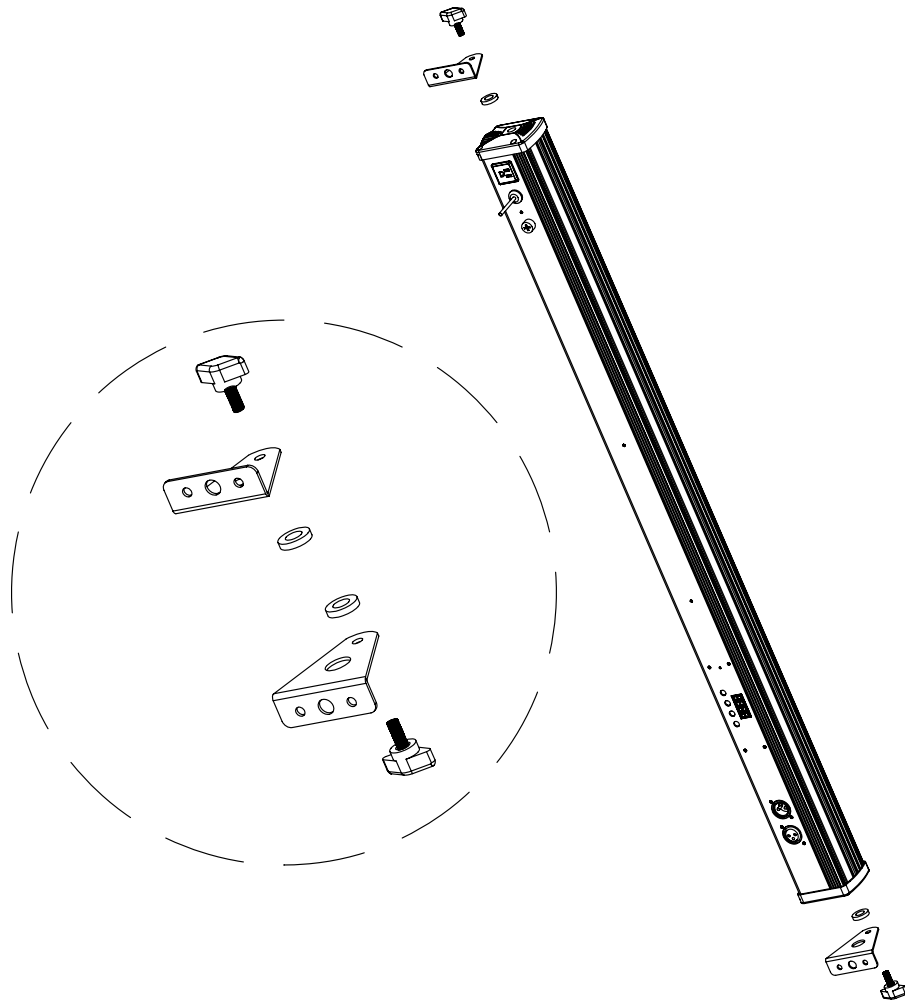

MANUFACTURER'S LIMITED WARRANTY

A. American DJ, Inc. hereby warrants, to the original purchaser, American DJ and American Audio products to be free of manufacturing defects in material and workmanship for a prescribed period from the date of purchase (see specific warranty period on reverse). This warranty shall be valid only if the product is purchased within the United States of America, including possessions and territories. It is the owner's responsibility to establish the date and place of purchase by acceptable evidence, at the time service is sought.

B. For warranty service you must obtain a Return Authorization number (RA#) before sending back the product. Contact American DJ, Inc. Service Department at 800-322-6337. Send the product only to the American DJ, Inc. factory. All shipping charges must be pre-paid. If the requested repairs or service (including parts replacement) are within the terms of this warranty, American DJ, Inc. will pay return shipping charges only to a designated point within the United States. If the entire instrument is sent, it must be shipped in its original package. No accessories should be shipped with the product. If any accessories are shipped with the product, American DJ, Inc. shall have no liability whatsoever for loss of or damage to any such accessories, nor for the safe return thereof.

C. This warranty is void if the serial number has been altered or removed; if the product is modified in any manner which American DJ, Inc. concludes, after inspection, affects the reliability of the product; if the product has been repaired or serviced by anyone other than the American DJ, Inc. factory unless prior written authorization was issued to purchaser by American DJ, Inc.; if the product is damaged because not properly maintained as set forth in the instruction manual.

D. This is not a service contract, and this warranty does not include maintenance, cleaning or periodic check-up. During the period specified above, American DJ, Inc. will replace defective parts at its expense with new or refurbished parts, and will absorb all expenses for warranty service and repair labor by reason of defects in material or workmanship. The sole responsibility of American DJ, Inc. under this warranty shall be limited to the repair of the product, or replacement thereof, including parts, at the sole discretion of American DJ. All products covered by this warranty were manufactured after January 1, 1990, and bear identifying marks to that effect.

E. American DJ, Inc. reserves the right to make changes in design and/or improvements upon its products without any obligation to include these changes in any products theretofore manufactured. No warranty, whether expressed or implied, is given or made with respect to any accessory supplied with products described above. Except to the extent prohibited by applicable law, all implied warranties made by American DJ, Inc. in connection with this product, including warranties of merchantability or fitness, are limited in duration to the warranty period set forth above. And no warranties, whether expressed or implied, including warranties of merchantability or fitness, shall apply to this product after said period has expired. The consumer's and/or Dealer's sole remedy shall be such repair or replacement as is expressly provided above; and under no circumstances shall American DJ, Inc. be liable for any loss or damage, direct or consequential, arising out of the use of, or inability to use, this product.

This warranty is the only written warranty applicable to American DJ and American Audio Products and supersedes all prior warranties and written descriptions of warranty terms and conditions heretofore published.

MANUFACTURER'S LIMITED WARRANTY PERIODS:

- All American Audio Products = 1-year (365 day) Limited Warranty (except V-Plus Series Amplifiers)
- All American Audio V-Plus Series Amplifiers = 3-year (1095 day) Limited Warranty
- American DJ Lighting and American DJ Branded Products = 1-year (365 day) Limited Warranty (Such as: Special Effect Lighting, Intelligent Lighting, UV lighting, Strobes, Fog Machines, Bubble Machines, Mirror Balls, Par Cans, Trussing, Lighting Stands etc. excluding Laser Products, lamps, and Star Tec Series)
- American DJ Laser Products and Star Tec Products = 90-Day Limited Warranty
- American DJ L.E.D. Products = 3-year (1095 day) Limited Warranty (excluding motors which have a 1-year (365 day) Limited Warranty)

Model: Mega Bar LED RCSPECIFICATIONS:

Working Position:	Any safe working position
Voltage:	90V ~ 240V, 50Hz/60Hz
LEDs:	251 x 10mm LEDs (48 Red, 108 Green, 95 Blue)
Power Cord Daisy Chain:	40 Fixtures Max.
Power Consumption:	30W
Beam Angle:	40 Degrees
Fuse:	1Amp
Weight:	8lbs./ 2.8Kgs.
Dimensions:	40.5" (L) x 2.75" (W) x 3.5" (H) 1025 (L) x 65 (W) x 88 (H) mm
Colors:	RGB Color Mixing
DMX Channels:	2, 3, 4, 6, 7, or 11 DMX Channels
Warranty:	3 Year (1095 days)

Auto Sensing Voltage: *This fixture contains a electronic ballast, which will auto sense the voltage when it is plugged into the power source.*

Please Note: Specifications and improvements in the design of this unit and this manual are subject to change without any prior written notice.

©American DJ Supply
American DJ World Headquarters:
6122 S. Eastern Ave. Los Angeles, CA 90040 USA
Tel: 323-582-2650 / Fax: 323-725-6100
Web: www.americandj.com / E-mail: info@americandj.com

American DJ Europe
Junostraat 2
6468 EW Kerkrade
Netherlands
service@americandj.eu / www.americandj.eu
Tel: +31 45 546 85 00 / Fax: +31 45 546 85 99