

Pioneer *sound.vision.soul*

COMPACT DISC PLAYER **CDJ-200**

Operating Instructions

COMPACT
disc
DIGITAL AUDIO

COMPACT
disc
DIGITAL AUDIO
TEXT

Thank you for buying this Pioneer product.

Please read through these operating instructions so you will know how to operate your model properly. After you have finished reading the instructions, put them away in a safe place for future reference.

In some countries or regions, the shape of the power plug and power outlet may sometimes differ from that shown in the explanatory drawings. However the method of connecting and operating the unit is the same.

K015 En

IMPORTANT



The lightning flash with arrowhead symbol, within an equilateral triangle, is intended to alert the user to the presence of uninsulated "dangerous voltage" within the product's enclosure that may be of sufficient magnitude to constitute a risk of electric shock to persons.



CAUTION:
TO PREVENT THE RISK OF ELECTRIC SHOCK, DO NOT REMOVE COVER (OR BACK). NO USER-SERVICEABLE PARTS INSIDE. REFER SERVICING TO QUALIFIED SERVICE PERSONNEL.



The exclamation point within an equilateral triangle is intended to alert the user to the presence of important operating and maintenance (servicing) instructions in the literature accompanying the appliance.

D3-4-2-1-1_En-A

NOTE: THE NO USER-SERVICEABLE PARTS COMPARTMENT WARNING IS LOCATED ON THE APPLIANCE BOTTOM.

IMPORTANT SAFETY INSTRUCTIONS

READ INSTRUCTIONS — All the safety and operating instructions should be read before the product is operated.

RETAIN INSTRUCTIONS — The safety and operating instructions should be retained for future reference.

HEED WARNINGS — All warnings on the product and in the operating instructions should be adhered to.

FOLLOW INSTRUCTIONS — All operating and use instructions should be followed.

CLEANING — The product should be cleaned only with a polishing cloth or a soft dry cloth. Never clean with furniture wax, benzene, insecticides or other volatile liquids since they may corrode the cabinet.

ATTACHMENTS — Do not use attachments not recommended by the product manufacturer as they may cause hazards.

WATER AND MOISTURE — Do not use this product near water — for example, near a bathtub, wash bowl, kitchen sink, or laundry tub; in a wet basement; or near a swimming pool; and the like.

ACCESSORIES — Do not place this product on an unstable cart, stand, tripod, bracket, or table. The product may fall, causing serious injury to a child or adult, and serious damage to the product. Use only with a cart, stand, tripod, bracket, or table recommended by the manufacturer, or sold with the product. Any mounting of the product should follow the manufacturer's instructions, and should use a mounting accessory recommended by the manufacturer.

CART — A product and cart combination should be moved with care. Culek stops, excessive force, and uneven surfaces may cause the product and cart combination to overturn.



VENTILATION — Slots and openings in the cabinet are provided for ventilation and to ensure reliable operation of the product and to protect it from overheating, and these openings must not be blocked or covered. The openings should never be blocked by placing the product on a bed, sofa, rug, or other similar surface. This product should not be placed in a built-in installation such as a bookcase or rack unless proper ventilation is provided or the manufacturer's instructions have been adhered to.

POWER SOURCES — This product should be operated only from the type of power source indicated on the marking label. If you are not sure of the type of power supply to your home, consult your product dealer or local power company.

LOCATION — The appliance should be installed in a stable location.

NONUSE PERIODS — The power cord of the appliance should be unplugged from the outlet when left un-used for a long period of time.

GROUNDING OR POLARIZATION

If this product is equipped with a polarized alternating current line plug (a plug having one blade wider than the other), it will fit into the outlet only one way. This is a safety feature. If you are unable to insert the plug fully into the outlet, try reversing the plug. If the plug should still fail to fit, contact your electrician to replace your obsolete outlet. Do not defeat the safety purpose of the polarized plug.

If this product is equipped with a three-wire grounding type plug, a plug having a third (grounding) pin, it will only fit into a grounding type power outlet. This is a safety feature. If you are unable to insert the plug into the outlet, contact your electrician to replace your obsolete outlet. Do not defeat the safety purpose of the grounding type plug.

POWER-CORD PROTECTION — Power-supply cords should be routed so that they are not likely to be walked on or pinched by items placed upon or against them, paying particular attention to cords at plugs, convenience receptacles, and the point where they exit from the product.

OUTDOOR ANTENNA GROUNDING — If an outside antenna or cable system is connected to the product, be sure the antenna or cable system is grounded so as to provide some protection against voltage surges and built-up static charges. Article B10 of the National Electrical Code, ANS/NFPA 70, provides information with regard to proper grounding of the mast and supporting structure, grounding of the lead-in wire to an antenna discharge unit, size of grounding conductors, location of antenna-discharge unit, connection to grounding electrodes, and requirements for the grounding electrode. See Figure A.

LIGHTNING — For added protection for this product during a lightning storm, or when it is left unattended and unused for long periods of time, unplug it from the wall outlet and disconnect the antenna or cable system. This will prevent damage to the product due to lightning and power-line surges.

POWER LINES — An outside antenna system should not be located in the vicinity of overhead power lines or other electric light or power circuits, or where it can fall into such power lines or circuits. When installing an outside antenna system, extreme care should be taken to keep from touching such power lines or circuits as contact with them might be fatal.

OVERLOADING — Do not overload wall outlets, extension cords, or integral convenience receptacles as this can result in a risk of fire or electric shock.

OBJECT AND LIQUID ENTRY — Never push objects of any kind into this product through openings as they may touch dangerous voltage points or short-out parts that could result in a fire or electric shock. Never spill liquid of any kind on the product.

SERVICING — Do not attempt to service this product yourself as opening or removing covers may expose you to dangerous voltage or other hazards. Refer all servicing to qualified service personnel.

DAMAGE REQUIRING SERVICE — Unplug this product from the wall outlet and refer servicing to qualified service personnel under the following conditions:

- When the power-supply cord or plug is damaged.
- If liquid has been spilled, or objects have fallen into the product.
- If the product has been exposed to rain or water.
- If the product does not operate normally by following the operating instructions. Adjust only those controls that are covered by the operating instructions as an improper adjustment of other controls may result in damage and will often require extensive work by a qualified technician to restore the product to its normal operation.
- If the product has been dropped or damaged in any way.
- When the product exhibits a distinct change in performance — this indicates a need for service.

REPLACEMENT PARTS — When replacement parts are required, be sure the service technician has used replacement parts specified by the manufacturer or have the same characteristics as the original part. Unauthorized substitutions may result in fire, electric shock, or other hazards.

SAFETY CHECK — Upon completion of any service or repairs to this product, ask the service technician to perform safety checks to determine that the product is in proper operating condition.

WALL OR CEILING MOUNTING — The product should not be mounted to a wall or ceiling. **HEAT** — The product should be situated away from heat sources such as radiators, heat registers, stoves, or other products (including amplifiers) that produce heat.

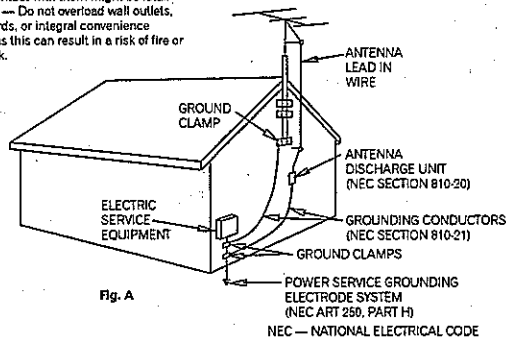

D1-4-2-2_En

NOTE: This equipment has been tested and found to comply with the limits for a Class B digital device, pursuant to Part 15 of the FCC Rules. These limits are designed to provide reasonable protection against harmful interference in a residential installation. This equipment generates, uses, and can radiate radio frequency energy and, if not installed and used in accordance with the instructions, may cause harmful interference to radio communications. However, there is no guarantee that interference will not occur in a particular installation. If this equipment does cause harmful interference to radio or television reception, which can be determined by turning the equipment off and on, the user is encouraged to try to correct the interference by one or more of the following measures:

- Reorient or relocate the receiving antenna.
- Increase the separation between the equipment and receiver.
- Connect the equipment into an outlet on a circuit different from that to which the receiver is connected.
- Consult the dealer or an experienced radio/TV technician for help.

D8-10-1-2_En

WARNING

This equipment is not waterproof. To prevent a fire or shock hazard, do not place any container filled with liquid near this equipment (such as a vase or flower pot) or expose it to dripping, splashing, rain or moisture.

D3-4-2-1-3_A_En

When using this product follow the instructions written on the underside of the unit, which concern rated voltage, etc.

D3-4-2-4_En

IMPORTANT NOTICE — THE SERIAL NUMBER FOR THIS EQUIPMENT IS LOCATED IN THE REAR. PLEASE WRITE THIS SERIAL NUMBER ON YOUR ENCLOSED WARRANTY CARD AND KEEP IN A SECURE AREA. THIS IS FOR YOUR SECURITY.

D1-4-2-6-1_En

CAUTION: USE OF CONTROLS OR ADJUSTMENTS OR PERFORMANCE OF PROCEDURES OTHER THAN THOSE SPECIFIED HEREIN MAY RESULT IN HAZARDOUS RADIATION EXPOSURE.

CAUTION: THE USE OF OPTICAL INSTRUMENTS WITH THIS PRODUCT WILL INCREASE EYE HAZARD.

D6-8-2-1_En

Information to User

Alteration or modifications carried out without appropriate authorization may invalidate the user's right to operate the equipment.

D8-10-2_En

CAUTION: This product satisfies FCC regulations when shielded cables and connectors are used to connect the unit to other equipment. To prevent electromagnetic interference with electric appliances such as radios and televisions, use shielded cables and connectors for connections.

D8-10-3a_En

This Class B digital apparatus complies with Canadian ICES-003.

Cet appareil numérique de la Classe B est conforme à la norme NMB-003 du Canada.

D8-10-1-3_EF

CAUTION — PREVENT ELECTRIC SHOCK DO NOT USE THIS (POLARIZED) PLUG WITH AN EXTENSION CORD, RECEPTACLE OR OTHER OUTLET UNLESS THE BLADES CAN BE FULLY INSERTED TO PREVENT BLADE EXPOSURE.

ATTENTION — POUR PREVENIR LES CHOCS ELECTRIQUES NE PAS UTILISER CETTE FICHE POLARISEE AVEC UN PROLONGATEUR UNE PRISE DE COURANT OU UNE AUTRE SORTIE DE COURANT, SAUF SI LES LAMES PEUVENT ETRE INSEREES A FOND SANS EN LAISSER AUCUNE PARTIE A DECOUVRETT.

D2-4-4-1_EF

WARNING: Handling the cord on this product or cords associated with accessories sold with the product will expose you to lead, a chemical known to the State of California and other governmental entities to cause cancer and birth defects or other reproductive harm.

Wash hands after handling

D36-P4_En

POWER-CORD CAUTION

Handle the power cord by the plug. Do not pull out the plug by tugging the cord and never touch the power cord when your hands are wet as this could cause a short circuit or electric shock. Do not place the unit, a piece of furniture, etc., on the power cord, or pinch the cord. Never make a knot in the cord or tie it with other cords. The power cords should be routed such that they are not likely to be stepped on. A damaged power cord can cause a fire or give you an electrical shock. Check the power cord once in a while. When you find it damaged, ask your nearest PIONEER authorized service center or your dealer for a replacement.

S002_En

FEATURES

Designed for professional use by DJs, the CDJ-200 compact disc player provides all the functions and performance required in disco clubs while offering performance, sound quality and functionality superior to analog players.

DIGITAL JOG BREAK

Equipped with Digital Jog Break for original sound effects. Individual remix assist functions [JET], [ZIP] and [WAH] have been provided individually in three buttons. By choosing a function and operating the jog dial in time with the music, a new remix world can be experienced.

JOG DIAL

A large 100 mm diameter jog dial enables corrections to uneven beats with the feeling of an analog turntable.

■ PITCH BEND

This function changes the music tempo depending on the direction and speed the jog dial is rotated.

■ FRAME SEARCH

Moves the pause position in frame units (1/75 sec) when the jog dial is rotated in the pause mode.

■ SUPER-FAST SEARCH

By turning the jog dial while holding down the manual search button or the track search button, disc search can be performed faster than normal search or track search functions.

TEMPO CONTROL

100 mm long high-precision slider allowing free speed adjustment

With a digital display calibrated in 0.02 % units (within a ± 6 % range), tempo adjustments can be made more easily and accurately.

■ TEMPO CONTROL RANGE

The maximum variable range can be set to three variable ranges; ± 6 %, ± 10 %, ± 16 %, to provide easier operation environment.

■ MASTER TEMPO

Maintains the same pitch of sound while changing the music tempo.

CUE

■ BACK CUE

After storing cue points in memory, press the CUE button while playing a track to return and start from the stored cue point.

■ AUTO CUE

Skips the non-recorded part at the top of a track and automatically enters stand-by mode at the track's starting point, allowing playback to begin instantly when the PLAY/PAUSE button (▶/||) is pressed.

■ CUE POINT SAMPLER

Playback can be started at one touch from a stored cue point, convenient for confirming start points and as sampler.

REAL TIME SEAMLESS LOOP

This function simplifies the setting and canceling of loops. The loop can be set at the very instant the track is being played. By setting a loop just before the end of the track, the track can be made so that it doesn't stop. In addition, an ADJUST mode has been added to enable one-touch adjustments to the loop-out point, thereby facilitating the loop operation.

RELOOP

Allows returning to the set loop position any number of times. Press the RELOOP/EXIT button after canceling loop play to return to the loop start position. By using the loop ON and OFF combined with the rhythm of the track, new sound effects can be created.

PLAYING ADDRESS

The bar graph provides a visual reference of the track playback progress that enables the user to visualize the current playback position, in the same way as is done with an analog record by checking the position of the needle. The current position can be confirmed by the length of the graph, and in addition, the graph flashes to notify the ending of the track.

SLOT IN

The disc can be inserted without the opening of trays and doors, making possible quick track selection.

FADER START

By connecting this unit to DJ mixer DJM-500, DJM-600, DJM-300, DJM-3000, DJM-909, or DJM-707, QUICK START and BACK CUE functions can be performed by using the mixer's fader function.

RELAY PLAY

Two CDJ-200 units can be connected in tandem to perform automatic relay play.

When track playback stops on one of the players, the standby mode of the other player is released and playback begins automatically.

OIL DAMPER FLOAT

OIL DAMPER FLOAT construction helps resist shakes and impacts.

This unit features an OIL DAMPER FLOAT design, making it harder for distortions and sound breakup to occur due to impacts from operation and vibrations from the floor.

MULTI READ

Supports playback of CD-R and CD-RW discs. (Some discs may not replay properly, however, due to certain special characteristics of some discs and recorders, as well as due to dirty or damaged discs.)

CD TEXT

Displays CD TEXT on CD TEXT-supported discs.

PLAYING MP3 FILES

MP3 files must follow the format requirements listed below.

MP3 format	MPEG-1	Supports Audio Layer-3 sampling frequency 32 kHz, 44.1 kHz, 48 kHz, BitRate 32 Kbps ~ 320 Kbps.
	MPEG-2	Supports Audio Layer-3 sampling frequency 16 kHz, 22.05 kHz, 24 kHz, BitRate 16 Kbps ~ 160 Kbps.
		Does not support Variable BitRate (VBR).
	ID3 tag	Displays only file name, artist, album name. ID3 tag title not displayed.
Disc format	File extension	.mp3, .MP3, .mP3, .Mp3
	Folder levels	Maximum of 8 folders. Files located in folders exceeding 8 levels cannot be played.
	Maximum number of folders	99 (99 folders + 1 root)
	Maximum number of files	999 (per folder)
	Multi-session	Does not support multi-session. When the disc used is a multi-session disc, only the first session will be played.
	CD-R recording method	Record following the ISO9660 CD-ROM file system. Supports only Disc At Once or Track At Once. CDJ-200 does not support Packet Write recorded discs.

* The song title displayed in the text mode will be the file name.

* CDJ-200 is not equipped with a File Sort function; tracks will be played in the order in which they were recorded.

CONTENTS

BEFORE OPERATING			
FEATURES	3	Fast-Forward/Fast-Reverse	12
PLAYING MP3 FILES	4	Track Cueing	12
CAUTIONS REGARDING HANDLING	5	Folder Search	12
CONNECTIONS	6	Change Playback Speed	12
PANEL FACILITIES	8	Applying Master Tempo	13
OPERATIONS		Digital Jog Break	13
DISC LOADING/UNLOADING	10	Cue Point Settings	13
OPERATIONS	11	Mixing Different Tracks	14
Auto Cue Function	11	Loop Playback	14
Starting Playback	11	Fader Start Playback	15
Resume Function	11	Relay Play Using Two Players	15
To Stop Playback	11	OTHER	
To Temporarily Interrupt Playback	11	TROUBLESHOOTING	16
Jog Dial Functions	11	SPECIFICATIONS	18

CAUTIONS REGARDING HANDLING

Location

Install the player in a well-ventilated location where it will not be exposed to high temperatures or humidity.

Do not install the player in a location which is exposed to direct sunlight, or near stoves or radiators. Excessive heat can adversely affect the cabinet and internal components. Installation of the player in a damp or dusty environment may also result in a malfunction and can be hazardous. Avoid installation near cookers etc., where the player may be exposed to oily smoke, steam or heat.

Installation Guidelines

- Placing and using the compact disc player for long periods on heat-generating sources such as amplifiers or near spotlights, etc. will affect product performance. Avoid placing the player on heat-generating sources.
- Install this compact disc player as far as possible away from tuners and TV sets. A compact disc player installed in close proximity to such equipment may cause noise or degradation of the picture.
- Noise may be noticeable when an indoor antenna is used. In such cases, make use of an outdoor antenna or turn off power to the compact disc player.
- When the unit is used in a loud-sound environment, e.g., near a speaker, sound skip may occur. Install the unit away from the speaker or reduce the listening volume.
- Place this unit on a level surface and a stable platform.
- Be sure the player, including its audio and power supply cords, does not touch vibrating materials. Any cause of vibration other than the insulators may cause the disc to skip. Take special care when using the player while it is installed in a carrying case.

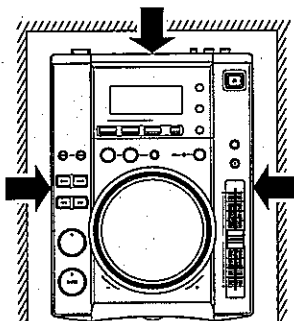

• Please be sure to leave a space to allow for heat radiation.

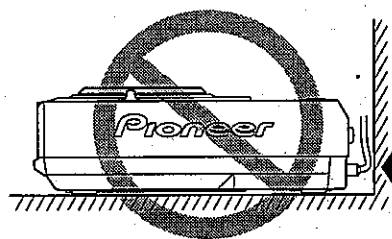

Do not place on or against vibrating materials!

Cleaning the Player

To clean the PLAYER wipe with a polishing or a soft, dry cloth. For stubborn dirt, moisten a soft cloth with a weak solution of neutral detergent (diluted in five to six parts water), wring the cloth well, and wipe away the dirt. Use a dry cloth to wipe the surface dry. Do not use volatile liquids such as benzene or thinner which will damage the unit.

CD Lens Cleaner

The player's pickup lens should not become dirty in normal use. If for some reason, the lens becomes soiled and malfunctions, contact your nearest PIONEER authorized service center. Lens cleaners for CD players are commercially available, but special care should be exercised in their use as some may cause damage to the lens.

Copy Controlled CDs

This product is designed to play discs in conformity with CD standards; no guarantee is given for operation or performance when using CDs which do not conform to these CD standards.

Storing Discs

- Discs are made of the same kinds of plastic used for conventional analog audio records. Be careful not to allow discs to warp. Always store discs in their cases vertically, avoiding locations with high heat, humidity, or extremely low temperatures. Avoid leaving discs in cars; the interior of a car in direct sunlight can become extremely hot.
- Always read and abide by the precautionary notes listed on disc labels.

Condensation

When this unit is brought into a warm room from previously cold surroundings or when the room temperature rises sharply, condensation may form inside the unit and impair its performance. In such cases, allow the unit to stand for about an hour or raise the room temperature gradually.

Cleaning and Handling Compact Discs

- The presence of fingerprints or smudges on the surface of the disc will not directly affect the recorded signals, but, depending on the degree of contamination, the brightness of the light reflected from the signal surfaces may be reduced causing degradation of sound quality. Always keep your discs clean by wiping them gently with a soft cloth from the inner edge toward the outer edge.



- If a disc becomes very dirty, dampen a soft cloth with water, (be sure to wring it out well) and wipe the away dirt gently. Remove any water drops with another soft, dry cloth.
- Do not use record cleaning sprays or anti-static agents on discs. Never clean discs with benzene, thinner, or other volatile solvents or damage to the disc surface may result.

- With this player, use only those discs which display the mark shown right (Optical audio digital discs).



- SACD hybrid discs cannot be played.

- When holding discs, do not touch their signal surfaces. Hold by the edges, or by one edge and the center hole.
- Do not affix gummed labels or tape to the disc surface. Also, do not scratch or damage the label.
- Discs rotate at high speeds inside the player. Do not use damaged, cracked or warped discs.

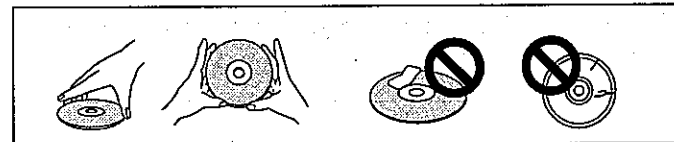

Do not play a CD with a special shape

Do not play a CD having other shape than a circular disc, such as heart shaped disc. Otherwise malfunction may occur.

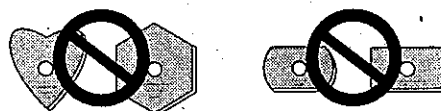

CONNECTIONS

Before making or changing connections, switch off the power and disconnect the power cord from the AC outlet.

1. Connecting to a DJ mixer (DJM-600, DJM-500, DJM-300, DJM-3000, DJM-909, DJM-707 (sound output and CONTROL connector))

Using the supplied audio cables, connect the white plug into the L (left) terminal and the red plug to the R (right) terminal. Connect the supplied control cable to enable control of the unit from the mixer for fader start play and back cue.

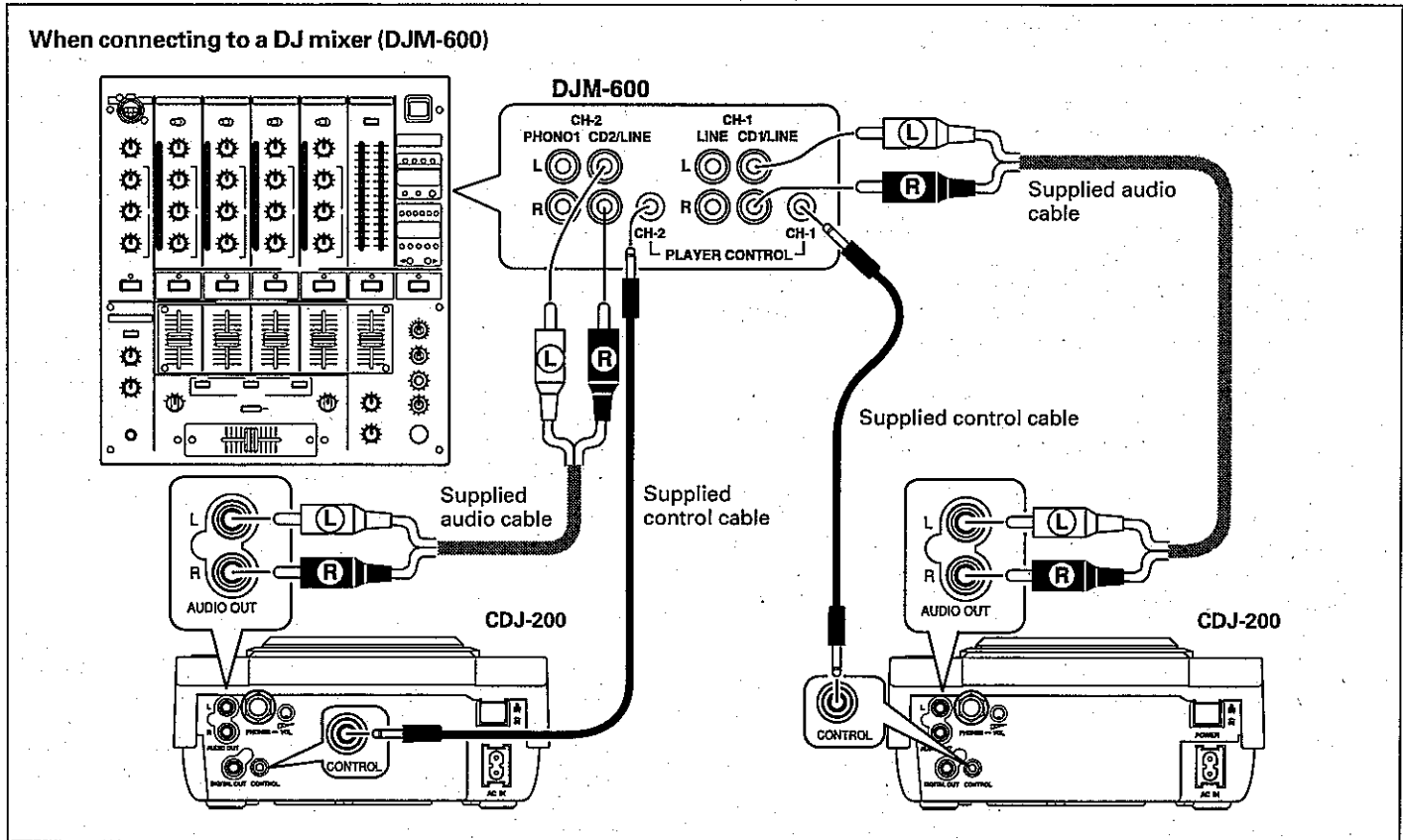

- When connecting to DJM-300 and DJM-500, connect as shown in the accompanying illustration.
- When connecting to DJM-909 and DJM-707, connect CH-1 CD with A PLAYER, CH-2 CD with B PLAYER using the supplied audio cables.
- When connecting to DJM-3000, connect A PLAYER to LINE 1 of CH-1, and B PLAYER to LINE 3 of CH-2.
- When connecting to an audio mixer other than the ones listed above, connect the unit's AUDIO OUT terminal to the mixer's line in terminal, or the AUX terminal (* do not connect to the PHONO terminal, since distortion or improper operation may occur).

2. Connecting control cable for relay play

Alternating playback can be automatically performed when the CONTROL connectors of the two units are connected with the supplied control cable. (P.15)

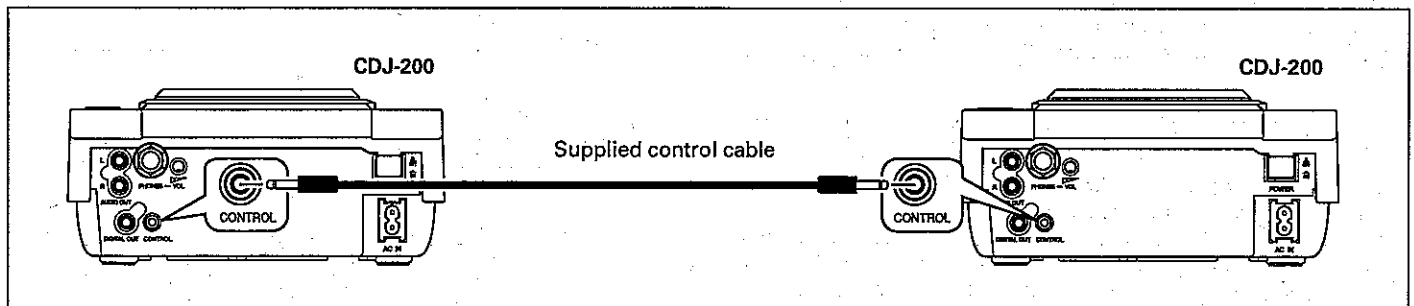

3. Connecting to other devices

A Connecting to headphones

- Headphones equipped with standard $\phi 6.3$ phone plug can be connected.
- Volume can be adjusted by the PHONES VOL dial.

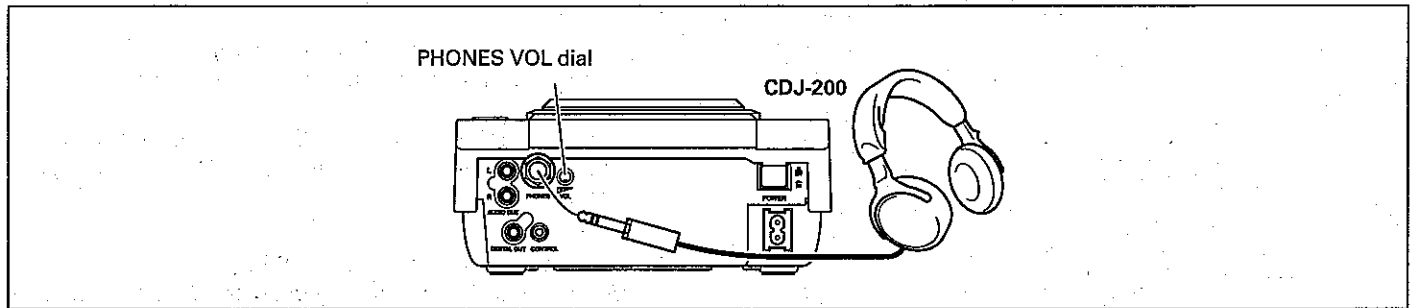

B Connecting to a stereo amplifier (when not using a DJ mixer)

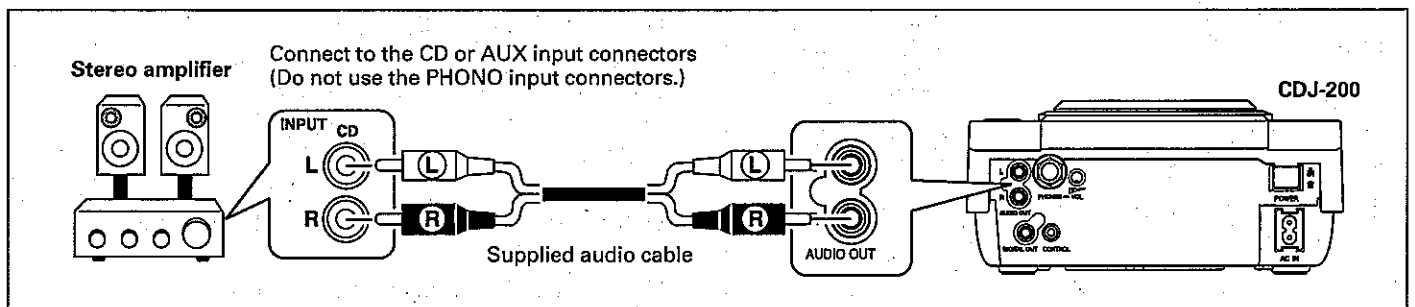

C Connecting to a component with digital input connectors

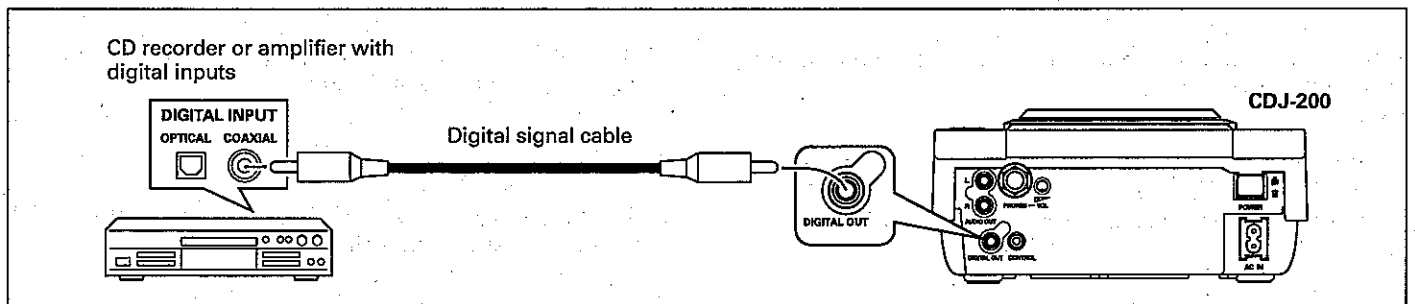

- The DIGITAL OUT connectors output only audio data without sub-codes. (Does not support CD Graphics.)
- DJ functions are not restricted when using audio data from the DIGITAL OUT connectors.

4. Connecting the power cord

After all other connections have been made, connect the power cord to the AC inlet on the rear panel of the player and connect the power plug to an AC wall outlet or to a power receptacle on the rear panel of the amplifier.

PANEL FACILITIES

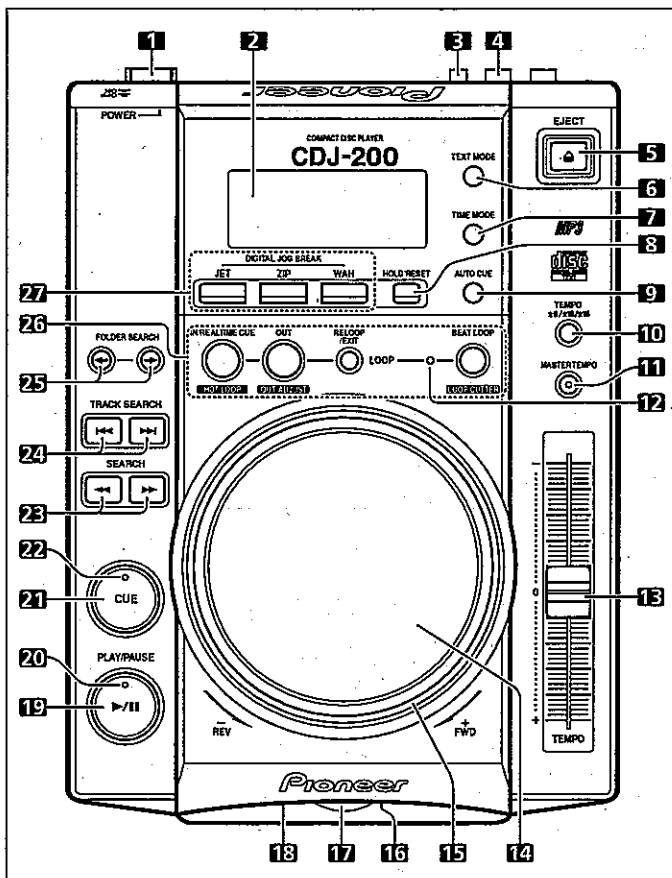

1. POWER switch (■OFF/ _ON)

This switch is located on the rear panel of the unit. Switches the unit's power ON/OFF.

2. Display

See 31~47.

3. PHONES VOL dial

Located on the rear panel of the unit. Adjusts the volume of the headphones.

4. PHONES connector

Located on the rear panel of the unit. ϕ 6.3 phone plug headphones can be connected.

5. EJECT button (▲)

Ejects the disc. (P.10)

6. TEXT MODE button

Changes the TEXT display. (P.9)

7. TIME MODE button

Toggles the time display between the remaining track time and elapsed time. (P.9)

8. HOLD/RESET button

Preserves the effect of the Digital Jog Break. (P.13)

9. AUTO CUE button

Toggles the Auto Cue ON/OFF. (P.11)

10. TEMPO control range button ($\pm 6/\pm 10/\pm 16$)

Changes the variable range of the tempo control. (P.12)

11. MASTER TEMPO button/indicator

Turns the Master Tempo function ON/OFF (lights when turned ON). (P.13)

12. BEAT LOOP indicator

Lights at the loop-in point during loop play.

13. TEMPO control slider

Controls the track's tempo (playback speed). (P.12)

14. Jog dial (-REV/+FWD)

15. Jog indicator

- When no disc is inserted, the indicator is turned off.
- When disc is inserted and in normal mode, indicator is turned on.
- When the Digital Jog Break is ON, indicator flashes rapidly.
- When Digital Jog Break is in HOLD ON mode, indicator flashes slowly.

16. Disc indicator

Located on the front panel of the unit.

- When no disc is inserted, the indicator is turned on.
- When disc is loading and unloading, indicator flashes.
- When disc loading is completed, indicator turns off.

17. Disc loading slot

Located in front panel. (P.10)

18. Forced ejection hole

Located in front panel of the unit. (P.10)

19. PLAY/PAUSE button (▶/||)

(P.11)

20. PLAY/PAUSE indicator (▶/||)

Lights when playing, and turns off when in pause mode.

21. CUE button

Use to set and confirm cue point. (P.13)

22. CUE indicator

Lights when cue point is set, and turns off when in pause mode.

23. SEARCH buttons (◀◀, ▶▶)

Use to perform fast-forward and fast-reverse (with sound) during playback mode. (P.12)

24. TRACK SEARCH buttons (◀, ▶)

Changes tracks in the forward/reverse direction. (P.12)

25. FOLDER SEARCH buttons (◀, ▶)

When using a CD-ROM with folder layers, use to change folders in the forward/reverse direction. (P.12)

26. LOOP buttons

■ IN/REALTIME CUE/HOT LOOP button/indicator

Use to input loop-in point. (IN P.14)

Use to set the current playback point as cue point (REALTIME CUE P.13).

When pressed during loop play, returns playback to loop-in point and begins replay (HOT LOOP P.14)

■ OUT/OUT ADJUST button/indicator

Use to input loop-out point. (OUT P.14)

When pressed during loop play, adjusts loop-out point. (OUT ADJUST P.15).

■ RELOOP/EXIT button

After finishing loop play, the stored loop-in/out information can be used to begin loop play again. (RELOOP P.15).

When pressed during loop play, loop play stops and playback returns to normal playback mode. (EXIT P.14)

■ BEAT LOOP/LOOP CUTTER button

When pressed during play or pause modes, the loop end is automatically set based on the track's BPM (Beat Per Minutes), and loop play starts (BEAT LOOP P.14).

When pressed during loop play, the length of the loop is cut to half its length (LOOP CUTTER P.14).

27. DIGITAL JOG BREAK buttons

Turns each sound effect ON/OFF: JET, ZIP, WAH. (P.13)

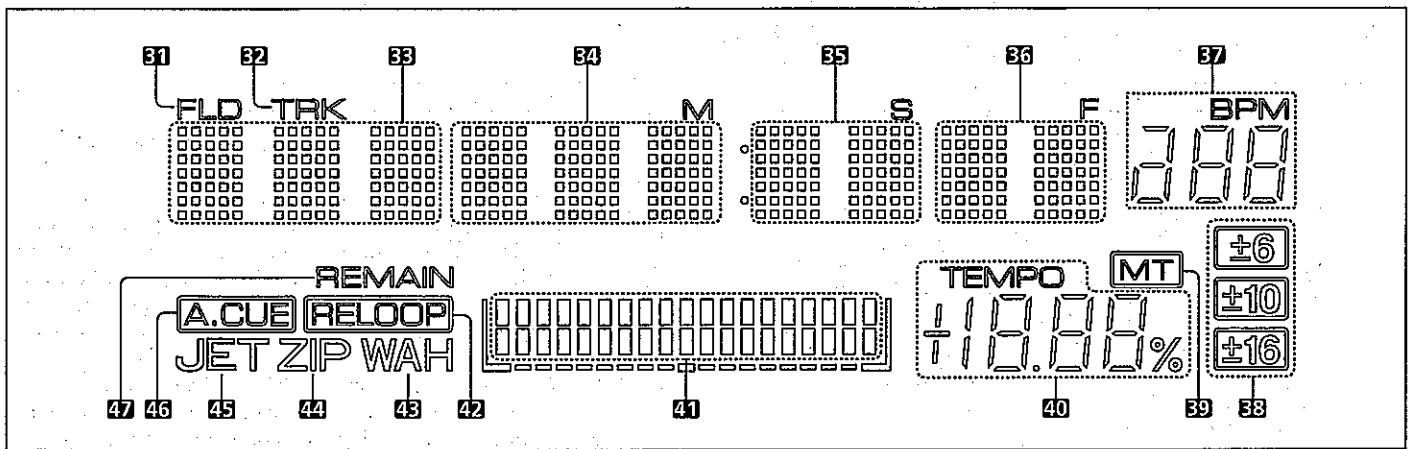

Display

31. FLD indicator

Lights when folder number is displayed.

32. TRK

Lights when track number is displayed.

33. Dot matrix display (7x5)x3

Displays folder number, track number, or alphanumeric data.

34. Dot matrix display (7x5)x3

Displays time (minutes) or alphanumeric data.

35. Dot matrix display (7x5)x2

Displays time (seconds) or alphanumeric data.

36. Dot matrix display (7x5)x2

Displays time (frame) or alphanumeric data.

37. BPM

Displays the BPM of the track displayed.

38. ±6, ±10, ±16

Lights to display tempo range.

39. MT

Lights when Master Tempo function is ON.

40. TEMPO

Displays the change rate of tempo.

41. Playing address display

Displays the current playback position in a one-track full-scale graph.

When displaying elapsed time, the graph lights from the left, and when displaying the remaining time the graph light turns off from the left.

When remaining time is less than 30 seconds, the graph flashes slowly, and when remaining time is less than 15 seconds the graph flashes rapidly.

42. RELOOP

Lights during reloop standby and loop play.

43. WAH

Flashes when Digital Jog Break WAH is turned on.

44. ZIP

Flashes when Digital Jog Break ZIP is turned on.

45. JET

Flashes when Digital Jog Break JET is turned on.

46. A.CUE

Lights when Auto Cue function is turned on.

47. REMAIN

Lights when the track remaining time is displayed.

Time display

- When the **TIME MODE** button is pressed, the display switches into Time Mode, and by pressing the **TIME MODE** button again, the display alternates between elapsed time (TIME) and remaining track time (REMAIN).
- The display mode is saved when the power is turned off.

Text display

- By pressing the **TEXT MODE** button when playing CD-TEXT or MP3s, the dot matrix display changes alternately as follows:
 - Track title (when playing MP3s, the file name)→Album title→Artist name.
- When no **TEXT** data is recorded, the display shows [NO TEXT].
- No more than 48 characters can be displayed.
- If all text data cannot be displayed at once, the text will scroll.
- To return to Time Mode display, press **TIME MODE** button.

DISC LOADING/UNLOADING

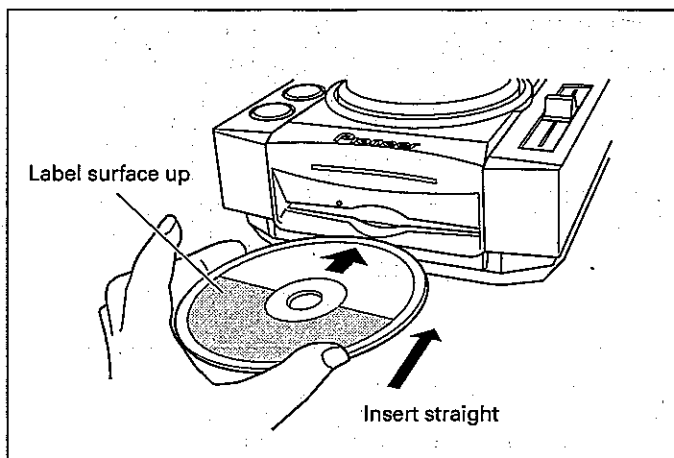

1. Set the rear-panel POWER switch to ON.

Do not force a disc into the unit when the POWER switch is set to OFF as this may damage the disc and the unit.

2. Insert a disc.

- Hold the disc with label surface upwards, and insert into the front panel disc loading slot.
- When playing 8cm discs, be sure to install an adaptor.
- Only one disc can be loaded at a time. Never attempt to load more than one disc at the same time, or attempt to load a second disc when one disc has already been loaded.
- When loading a disc, do not place any twisting force on the disc, or try to force the disc into the slot. Also, do not attempt to interrupt or defeat the motion of the disc when the player begins to draw a disc into the slot or to eject a disc, since damage to the disc or player could occur.

PRECAUTIONS ON PLAYING CD SINGLES (8 cm/3-inch Discs)

- ① When playing CD singles (8 cm/3-inch discs), always use the adaptor for 8 cm/3-inch discs. Before loading the disc into the CD player, be sure to check that it is secured properly by the catches of the adaptor. If discs have been inserted without the adaptor by mistake, remove the disc immediately by pressing the EJECT button (▲). If the disc does not come out with one press, press another time.
- ② Use 8 cm/3-inch disc adaptors labeled with the  mark (recommended standard product). Do not use adaptors which cause the disc to idle, nor adaptors which are bent or curved.

3. Press the EJECT button (▲) to remove the disc.

- When the EJECT button (▲) is pressed, disc rotation stops and the disc is ejected from the loading slot.
- If the disc cannot be ejected with the EJECT button (▲), insert a pin in the forced ejection hole on the front panel of the player.

■ Canceling eject command

In the event the EJECT button (▲) is pressed by mistake, if the PLAY/PAUSE (▶/II) button is pressed immediately (before [EJECT] is displayed), the eject command will be canceled and playback will restart from the place immediately before the EJECT button (▲) was pressed (during this time, sound output will be temporarily interrupted).

CAUTION:

Do not attempt to press a disc back into the slot when the [EJECT] indicator appears. Pressing a disc back into the slot while the [EJECT] indicator appears may cause the player to stop. In this case, press the EJECT button (▲) again and wait until the [EJECT] indicator goes out before reinserting the disc.

Forced disc ejection

If the EJECT button (▲) does not function or the disc cannot be removed, pushing the pin provided into the forced ejection hole on the front panel will enable the disc to be removed.

When performing forced ejection, be sure to follow the precautions below.

- ① Be sure to turn OFF the power of the CD player, and check that the disc has stopped rotating. It takes about 60 seconds for the disc to stop rotating after the power has been turned OFF.

If forced ejection is performed while the disc is rotating;

- As the disc will be ejected outside the CD player rotating, it may hit your finger and cause injuries.
- As the disc will be rotating with the clamp unstable, it may be scratched.

For the above reasons, never attempt to eject the disc forcibly while it is rotating.

- ② Always use the pin provided (Do not use other objects). **The provided pin is found in a groove in the bottom surface of the player.**

When the provided forced eject pin is inserted fully into the forced eject hole on the front panel, the loaded disc is ejected about 5-10 mm from the loading slot, making it possible to remove it by hand.

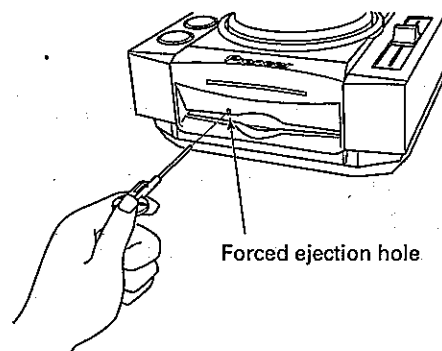

OPERATIONS

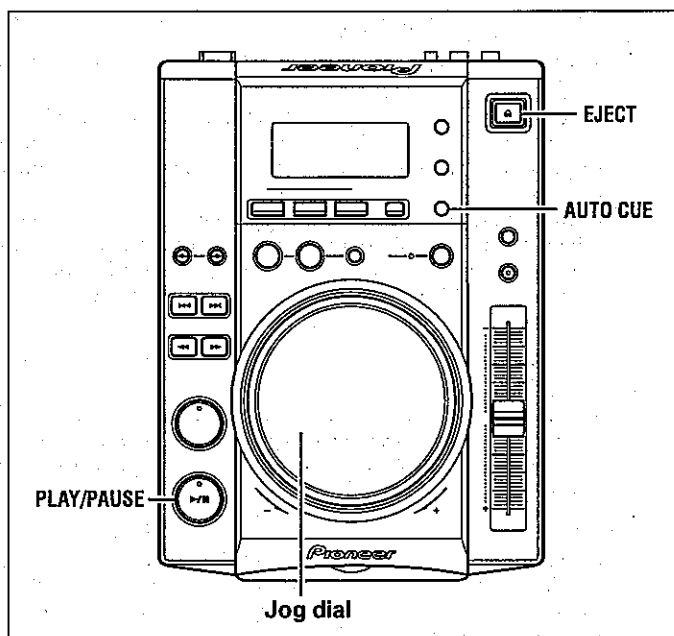

Auto Cue Function

When a disc is loaded or track search is performed, this function automatically sets the cue point (☞P.13) right before the track is actually played.

To turn ON/OFF

The Auto Cue function can be turned ON/OFF by pressing the AUTO CUE button. The Auto Cue is turned on when the Auto Cue indicator [A.CUE] appears in the display.

- The ON/OFF status of the Auto Cue function is stored in memory when the power is turned off.
- Auto Cue level is fixed to -60 dB.

Starting Playback

1. Insert disc in the player.

- When inserting a disc, keep the label-side up, and insert only one disc into the disc loading slot located in the front panel of the unit. (☞P.10)
- If a CD-ROM with no MP3 file in the first session is inserted, the display will read [NO TRACK] and the CD-ROM will not be played.

2. When Auto Cue function is ON, press the PLAY/PAUSE button (▶/||).

- Wait for the display's time display to appear before pressing the button. The non-recorded portion at the beginning of the displayed track will be skipped and playback will begin instantly. When the first track's playback ends, the player will automatically search for the beginning of the next track. The indicator on the CUE button will light, the PLAY/PAUSE button (▶/||) indicator will flash and the player will then wait for the PLAY/PAUSE button (▶/||) to be pressed before beginning playback of the next track.

When the Auto Cue function is turned off, playback will begin automatically from the first track.

- When Auto Cue function is turned off, playback will continue after the first track has been played, with all subsequent tracks being played in sequence.
- When playback of the final track is complete, playback will automatically come to an end.

When playing MP3s, after the playback of all the tracks inside a folder has finished, the unit will enter the standby mode at the end of the final track. When the PLAY/PAUSE button (▶/||) is pressed, playback will begin from the first track of the same folder.

Resume Function

When the same disc is inserted after being ejected once, the disc will be restarted from the place immediately before the disc was ejected. However, the Digital Jog Break function will not be restored. If desired, the TRACK SEARCH button can be pressed before playback begins to perform normal track search and playback.

If the disc is protruding from the disc loading slot, pressing the EJECT button (▲) will cause the resume function to be canceled.

To Stop Playback

1. Press the EJECT button (▲).

- Playback will stop and the disc will be ejected.
- The CDJ-200 is not provided with a conventional stop button.
- In the event the EJECT button (▲) is pressed accidentally, immediately (before [EJECT] is displayed in the display) press the PLAY/PAUSE button (▶/||) to cancel the eject command; playback will then restart from the place immediately before the EJECT button (▲) was pressed (during this time, sound output will be temporarily interrupted).

To Temporarily Interrupt Playback

Press the PLAY/PAUSE button (▶/||) during playback.

- The PLAY/PAUSE button (▶/||) indicator and the CUE button indicator will flash and playback will be paused.
- When the PLAY/PAUSE button (▶/||) is pressed again, the indicator on the button will light and the playback will continue.
- Broken sound will still be audible during the pause mode; to stop all sound, lower the output sound volume of the audio mixer.
- If there has not been any operation for more than 100 minutes in the pause mode, the disc rotation will automatically be stopped. By pressing the PLAY/PAUSE button (▶/||), the playback will be resumed from the first track.

Jog Dial Functions

[Pitch Bend]

Rotate dial during play.

- The track will accelerate (FWD+ =Clockwise)/slowdown (REV- =Counter-Clockwise) according to the amount and direction the jog dial is turned. The rate of change is up to $\pm 20\%$ (essentially linear change).
- When jog dial rotation stops, the speed returns to the speed before the jog dial was first rotated.
- Pitch Bend is disabled when the Digital Jog Break function is turned ON.

[Frame Search]

Rotate dial during pause.

- Moves audible pause position in frame units.
- Searches frames in the play direction when rotated clockwise, and the reverse direction when rotated counter-clockwise.
- 48 frames are searched in one full cycle of the jog dial.

[Cue point adjust]

☞P.13 "Changing the cue point"

[Super-Fast Search]

☞P.12 "Super-Fast search"

[Super-Fast track search]

☞P.12 "Super-Fast track search"

[Super-Fast folder search]

☞P.12 "Super-Fast folder search"

[Digital Jog Break]

☞P.13 "Digital Jog Break"

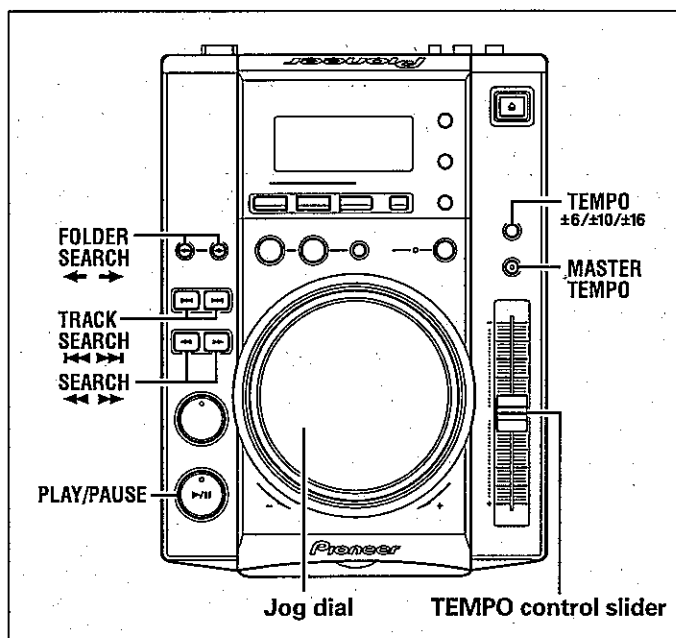

Fast-Forward/Fast-Reverse

SEARCH buttons (◀◀, ▶▶)

Press one of the SEARCH buttons (◀◀, ▶▶) during playback. Press and hold the ▶▶ button for fast forward the disc; press and hold the ◀◀ button for fast reverse.

- During playback of MP3s, fast-forward/fast-reverse are supported only for tracks inside the same folder.

Super-Fast search

Rotate the jog dial while pressing one of the SEARCH buttons (◀◀, ▶▶).

- Hold down one of the SEARCH buttons (◀◀, ▶▶) while turning the jog dial in the desired direction to enter super-fast forward or super-fast reverse mode.
- During Super-Fast search, the search direction is determined by the direction the jog dial is turned. The direction of the pressed SEARCH button (◀◀, ▶▶) is ignored.
- When the jog dial rotation stops, the unit returns to playback mode.
- When the SEARCH button (◀◀, ▶▶) is released, Super-Fast search is canceled.
- During playback of MP3s, fast-forward/fast-reverse is supported only tracks inside the same folder.

Track Cueing

TRACK SEARCH buttons (◀◀, ▶▶)

Press one of the TRACK SEARCH buttons (◀◀, ▶▶).

- Each time the button is pressed, the track is cued in the direction corresponding to the arrow on the button (during playback of a track, to cue playback to the beginning of the preceding track, press the ◀◀ button twice.) During playback of MP3s, the first track found in the direction pressed will be cued, and only those tracks inside the same folder are searched. If Folder Search is not performed when a CD-ROM is inserted, the tracks in the root directory only will be cued. In cases in which there are no tracks in the root directory, playback will start from the track with the smallest number in the first folder closest to the root directory.
- When the Auto Cue function is turned ON, the track will be set in cue standby position at the beginning of the track after cueing.
- When the TRACK SEARCH button (◀◀, ▶▶) is held depressed, cueing is performed continuously. If the button is held depressed for two seconds or more, the cue speed increases.
- By pressing the ◀◀ button twice at the beginning of the first track (Track NO.1), the last track will be cued. During playback of MP3s, when the ◀◀ button is pressed the track with the smallest number, the last track in the same folder will be cued.

- By pressing the ▶▶ button at the last track, the first track (Track NO.1) will be cued. During playback of MP3s, when the ▶▶ button is pressed at the last track, the track with the smallest number in the same folder will be cued.

Super-Fast track search

Rotate the jog dial while pressing one of the TRACK SEARCH buttons (◀◀, ▶▶).

- By turning the jog dial in the desired search direction while pressing either of the TRACK SEARCH buttons (◀◀, ▶▶), the track number will be searched corresponding to the turning of the jog dial.
- During Super-Fast track search, the search direction is determined by the direction of rotation of the jog dial. The direction of the pressed TRACK SEARCH button (◀◀, ▶▶) is ignored.
- When the TRACK SEARCH button (◀◀, ▶▶) is released, Super-Fast track search will be ended.

Folder Search

Folder search is used when searching tracks in a CD-ROM with folder layers. Folder search will not operate during playback of CD-DA discs.

FOLDER SEARCH buttons (←, →)

Press one of the FOLDER SEARCH buttons (←, →).

- Every time the FOLDER SEARCH button is pressed, the folder number and folder name will appear and the folders will be skipped to the specified direction. The root directory is displayed as folder number [00], folder name [ROOT].
- By holding either of the FOLDER SEARCH buttons depressed, folders will be searched continuously. If the button is held for two seconds or more, the search speed increases.
- When reverse search is performed from the lowest-numbered folder, the last folder will be searched. When forward search is performed from the last folder on the disc, the lowest-numbered folder will be searched.
- When in Text Mode, after searching a folder, the folder number and folder name will first appear, followed by the track number and file name of the first track in the folder. When in Time Mode, the file name will not appear.
- Folders with no playable tracks (empty folders) will be ignored, and the next folder will be searched.

Super-Fast folder search

Rotate the jog dial while pressing one of the FOLDER SEARCH buttons (←, →).

- By turning the jog dial in the intended search direction while pressing either of the FOLDER SEARCH buttons, folder numbers will be searched corresponding to the direction of rotation of the jog dial.
- During Super-Fast folder search, the search direction is determined by the direction the jog dial is rotated. The direction indicated by the pressed FOLDER SEARCH button is ignored.
- When the FOLDER SEARCH button is released, Super-Fast folder search is canceled.

Change Playback Speed

Sliding the TEMPO Control slider forward and back.

By sliding the lever towards you (+) increases the tempo; sliding the lever away from you (-) decreases the tempo. The center detent position is the normal speed.

- The rate of change in playback speed (tempo) is shown in the display.
- The playback speed can be changed without changing the pitch (≡ "Applying Master Tempo").

Selecting range of tempo adjustment

Press the TEMPO ±6/±10/±16 button.

Each time the button is pressed, the variable range of the TEMPO control slider alternates between ±6%, ±10%, and ±16%. The tempo can be adjusted in units of 0.02% when set to ±6%, and units of 0.05% when set to either ±10% or ±16%.

- The set variable range is shown in the display.
- When the power is turned on, the variable range is set by default to ±10%.

Applying Master Tempo

Press the **MASTER TEMPO** button during playback.

The **MASTER TEMPO** button and the [MT] indicator in the display will light, and the speed (tempo) can be changed using the **TEMPO** control slider without changing the pitch (key).

- Due to digital processing of the sound, the sound quality will drop.

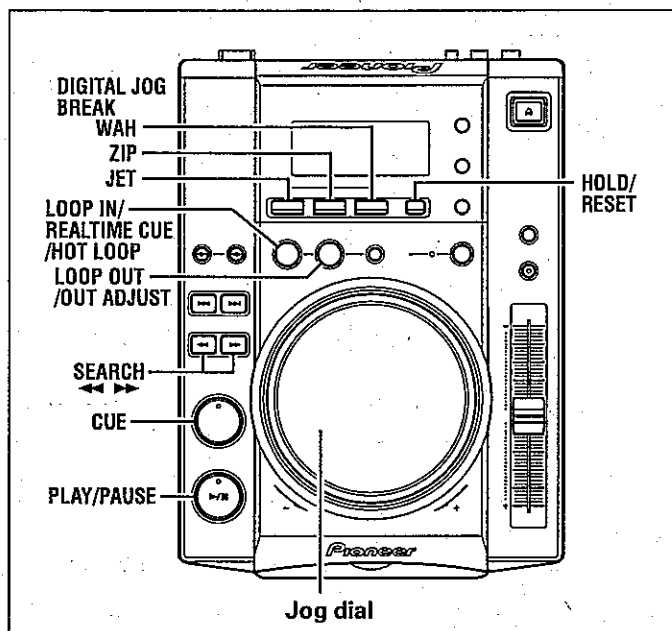

Digital Jog Break

Press one of the **DIGITAL JOG BREAK** buttons (**JET**, **ZIP**, **WAH**) during playback.

- The selected effect's indicator in the display will flash, and the effect will change corresponding in response to the rotation of the jog dial.
- When Digital Jog Break function is ON, the jog indicator will flash.

JET

Changes the delay time in response to rotation of the jog dial, and adds a short delay sound to the original, thereby causing an interference between the sounds and creating a "swooshing" effect.

- The delay time corresponds to the jog dial's rotation and changes between 0 ms (when jog dial is completely stopped) to a maximum of 3 ms.
- When the jog dial is rotated continuously, the delay time repetitively changes between 0~3 ms.
- When rotation of the jog dial stops, the sound will gradually settle back to the original sound.
- The setting is canceled when the disc is ejected.

ZIP

Changes the pitch in response to the turning of the jog dial, thereby changing the playback sound.

- The pitch change corresponds to the turning of the jog dial; when the jog dial is stopped the pitch change is 0%. When the jog dial is turned clockwise, the pitch changes within the maximum of 100% (1 octave higher than the original sound). When the jog dial is turned counterclockwise, the pitch changes within the maximum of -150% (15 octaves lower than the original sound, a non-audible frequency).
- When rotation of the jog dial stops, the sound will gradually settle back into the original sound.
- The setting is canceled when the disc is ejected.
- If the **HOLD** function is turned ON and the setting is made in the minus direction, when the **HOLD** function is next turned ON again, the "break" effect will be produced.

WAH

Adds a -12 dB/octave filter with cutoff frequency that changes in response to jog dial rotation.

- The filter changes into a maximum 4 kHz high-pass filter when the jog dial is turned clockwise; the filter changes into a minimum 150 Hz low-pass filter when the jog dial is turned counterclockwise.
- When rotation of the jog dial stops, the sound gradually returns to the original sound.
- The setting is canceled when the disc is ejected.

[HOLD function]

Used to maintain the effect that has been created by the turning of the jog dial even after the jog dial's rotation is stopped.

Press the **HOLD** button during usage of Digital Jog Break function.

- The [JET], [ZIP], or [WAH] indicator in the display stops flashing and lights steadily, and the effect created at that point is maintained so that the jog dial's turning can be stopped.
- When the Time Mode is selected and **HOLD** function is turned on, a **HOLD** indicator ([JET-HOLD], [ZIP-HOLD], [WAH-HOLD]) will be shown in intervals in the section where the time is displayed. When **TEXT** mode is selected, this will not be displayed.
- When the **HOLD** function is turned ON, even if another effect is selected, the setting prior to the new effect selection will be preserved in memory so long as hold is not turned off.

Cue Point Settings

Once a cue point has been stored in memory, it can be used during playback to set the player in the cue standby mode (ready to begin playback from the cueing position by pressing the **CUE** button).

1. During playback, press the **PLAY/PAUSE** button (▶/II) to pause playback at the point you wish to set as cue point.
2. Search for the precise position of the cue point.

- Using frame numbers to specify cue points.

Cue points may be specified in 1-frame units (where 75 frames are equivalent to 1 second).

Use the jog dial or the forward or reverse **SEARCH** button (◀◀, ▶▶) to advance to the desired frame. Each rotation of the jog dial corresponds to 48 frames in the specified direction; by pressing the **SEARCH** button (◀◀, ▶▶) frames will advance 1 frame in the specified direction. During the playback of MP3s, only files inside the same folder can be searched.

- Listening to the sound to determine the cue point.

While turning the jog dial slowly, return the track to the point immediately before the desired playback point (The cue point will be the point directly after the sound which can be heard during the cueing pause).

3. Press the **CUE** button when the frame number or sound has reached the desired cueing point.

- The sound is muted, and the time display lights steadily when the cue point has been stored in memory.
- Each time a new cue point is stored to memory, the previous cue point will be erased.

[Changing the cue point]

1. Press the **CUE** button during playback.
 - This will take you back to the set cue point.
2. Press the **SEARCH** button (◀◀, ▶▶) and set to audible pause mode.
3. Go through steps 2 and 3 of "Cue Point Settings" mentioned above.

■ REALTIME CUE

During playback, press the **IN/REALTIME CUE/HOT LOOP** button at the desired cueing point.

- This point will be set as a new cue point.

■ Back Cue (returning to cue point)

1. Press the **CUE** button during playback.
 - This will take you back to the set cue point.
 - During the playback of MP3 files, back cue can be performed only within the same folder. As long as a new cue point is not overwritten, the cue point will be saved after folder search as well.
2. Press the **PLAY/PAUSE** button (▶/II).
 - Playback will instantly start from the set cue point.

■ **Cue point sampler (confirming cue points)**

After specifying a cueing point, press the CUE button in the cue standby mode.

- The sound at the specified cue point will continue to play as long as the CUE button is pressed.
- During playback of MP3s, sounds can be heard only for cue points within the same folder.

Mixing Different Tracks

Example: Mix track B with track A which is currently playing from the speakers

- Connect CD1 to the DJ mixer's CH-1, and connect CD2 to CH-2.
- Raise the TRIM, CHANNEL FADER, and MASTER VOLUME settings appropriately so that sound is produced from CD1.

1. Set the DJ mixer's CROSS FADER slider at its left side (CH-1).

- Track A is heard from speakers.

2. Load a CD on player CD2.

3. Press the TRACK SEARCH (◀▶) on player CD2 to find and select track B.

4. Operate the DJ mixer's MONITOR SELECTOR button to monitor CH-2.

5. Turn the DJ mixer's MONITOR LEVEL dial so that track B can be heard from the headphones.

- Only track A is heard from the main speakers.

6. Set cueing position for track B on the headphones.

- ① With player CD2 in the playback mode, press the PLAY/PAUSE button (▶/||) near the desired cueing point.

- The player will enter the audible pause mode.

- ② Rotate player CD2's jog dial and search for the track's cueing point (first beat).

- ③ When cueing point is found, press player CD2's CUE button.
- The player's sound will be muted and cueing will be completed.

7. Simultaneously press player CD2's PLAY/PAUSE button (▶/||) along with the sound of track A played from the speakers.

- Only track A will be heard from the main speakers.
- Track B will be heard from the headphones.

8. Move the TEMPO control slider so that the tempo (BPM=Beat Per Minutes) of track B and A matches.

Move the TEMPO control slider of player CD2's so that the BPM of track B matches the BPM of track A.

- When the two BPM rates match, the BPM synchronization is complete.

9. Press the CUE button on player CD2.

- Player CD2 will enter pause mode at the cue point.

10. Press the PLAY/PAUSE button (▶/||) of player CD2 in time with track A of player CD1 (the sound heard from speaker).

- Track B will begin playing.

11. While checking the sound on the headphones, gradually move the DJ mixer's CROSS FADER slider from left to right.

- The sound of track A from the speakers will gradually be mixed with the sound of track B.
- When the DJ mixer's CROSS FADER slider is completely moved to the right side, the sound heard from the speaker will have changed from track A to track B, and the operation is complete.

■ **Long Mix Play**

If the BPM rates match, the mixed sound of track A and track B will not sound unnatural even if the CROSS FADER slider is placed in the middle position.

■ **Fader Start Play**

By using the Cross Fader Start function of the DJM-600, DJM-500, DJM-300, DJM-3000, DJM-909 or DJM-707, step 10 above can be skipped for simpler mixing.

In addition, when the CROSS FADER slider is returned to its original position, the status returns to that in step 9, so that the same play can be repeated.

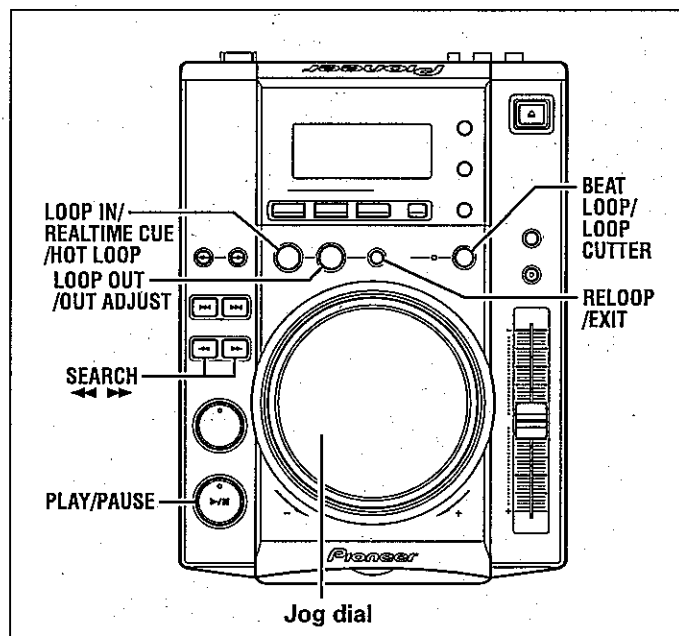

Loop Playback

■ **Creating a loop**

1. Press the PLAY/PAUSE button (▶/||) button to start playback.

2. During playback, press the IN/REALTIME CUE/HOT LOOP button at the loop-in point.

- Note that this operation is not needed if a prerecorded cue point is to be used as the start of the loop.

3. During playback, press the OUT/OUT ADJUST button at the desired loop-out point.

- Loop playback will start between the loop-in point and loop-out point.
- By using the frame search, the loop-out point can be set in units of frames.
- During playback of MP3s, looping is only possible within one and the same track set having a cue point.

■ **To start loop playback with automatically set loop-out point (Auto BEAT LOOP)**

Press the BEAT LOOP/LOOP CUTTER during playback or pause mode.

- The point at which the button is pressed will be set as the loop-in point, and a loop-out point will automatically be set based on the track's BPM; loop playback will then start.
- If the numerical BPM value is not displayed, loop play will begin based on BPM=130.

■ **To cut the loop length in half (LOOP CUTTER)**

Press BEAT LOOP/LOOP CUTTER button during loop playback.

- The loop length will be cut down to one-half each time the button is pressed (Smallest loop length is one frame).

■ **Returning to loop-in point during loop playback to start over the loop playback (HOT LOOP)**

Press IN/REALTIME CUE/HOT LOOP button during loop playback.

- Returns to loop-in point and restarts loop playback.

■ **To exit loop playback**

Press RELOOP/EXIT button during loop playback.

- The track will continue playback in sequence from the loop out point without returning to the loop-in point.

■ Changing the loop-out point

1. Press the **OUT/OUT ADJUST** button during loop playback.
 - The time of the out point is shown in the display, the **OUT/OUT ADJUST** button starts to flash rapidly and the **IN/REALTIME CUE/HOT LOOP** button indicator turns off.
2. Press one of the **SEARCH** buttons (**<<**, **>>**) or turn the jog dial.
 - The loop-out point is moved forwards or backwards in 1-frame units.
 - The loop-out point cannot be moved before the loop-in point.
 - During playback of MP3s, loop adjustment is only possible within one and the same track set having a cue point.
 - Pressing the **OUT/OUT ADJUST** button or waiting 30 seconds or longer will cause the player to exit from the loop-out adjust mode and to resume loop playback.

■ Returning to loop playback (RELOOP)

After loop playback has been stopped, press the **RELOOP/EXIT** button during playback.

- The player will return to the currently defined loop start point and begin loop playback again from that point. The length of the loop will be the same as the one first set, even if the loop cutter was subsequently used.
- During playback of MP3s, re-looping is possible only within the same folder.

Fader Start Playback

The supplied control cable may be used to connect the **CONTROL** connector of the CDJ-200 to the matching **CONTROL** connector on a DJM-300, DJM-500, DJM-600, DJM-3000, DJM-909 or DJM-707 DJ mixer, thus making it possible to exit from cueing standby mode and start playback immediately by raising the channel fader on the DJ mixer. The cross fader may also be used to perform fade-in starts on the player as well. The fader may also be returned to its original position to return the player to the cueing point (back cueing.) (See P.6 for instructions on connecting the units.)

Relay Play Using Two Players

By using the supplied control cable to connect the **CONTROL** connectors of two CDJ-200, or other CDJ series CD players, relay play can be performed. (P.6)

- Set both players' auto cue function to ON (The [A.CUE] indicators will light in the displays.)
- Set the DJ mixers Cross Fader control to its center position.

1. **Begin playback on the first player.**
2. **When the currently playing track ends, playback will begin automatically on the standby player.**
3. **The first player will enter cue pause mode at the beginning of the next track on its disc.**

- By repeating this operation, the two players can be used to perform continuous relay play.
- By loading new discs and choosing desired tracks on the player in standby, a continuous program of selected tracks can be played.
- By setting a cue point on the standby player, a relay of any desired cue point of the selected track can be performed. (P.13 "Cue Point Settings")

Note:

- Relay play may not operate properly if the **AUDIO OUT** jacks on the two players are not connected to the same DJ mixer.
- If the power to one player is turned off during its playback, the other player may begin playback.
- Fader start and relay play cannot be performed simultaneously, since different control cord connections are required.

TROUBLESHOOTING

Incorrect operations can be mistaken as malfunctions. If you believe the unit is not operating correctly, consult the chart below. Sometimes incorrect operation may be due to a malfunction in another component. If the problem is not fixed, check the other components used with the player. If the problem still persists, contact your nearest Pioneer authorized service center or dealer for service.

Symptom	Cause	Remedy
Disc doesn't eject even when EJECT button (▲) is pressed.	<ul style="list-style-type: none"> Power plug is disconnected from outlet. 	<ul style="list-style-type: none"> Connect plug to wall outlet.
Play doesn't commence even when the disc is inserted.	<ul style="list-style-type: none"> The auto cue function is set to on. 	<ul style="list-style-type: none"> Press the AUTO CUE button to turn off the Auto Cue function.
Playback immediately stops when started. During playback, the player pauses or stops.	<ul style="list-style-type: none"> Smudges on the disc, etc. 	<ul style="list-style-type: none"> Clean the smudges from the disc and then play it again.
No sound is audible.	<ul style="list-style-type: none"> Output cables are connected incorrectly or are loose. Incorrect operation of DJ mixer. Pin plugs and/or amplifier terminals are dirty. Player is in pause mode. 	<ul style="list-style-type: none"> Recheck connections. Refer to installation instructions. Check the settings of the DJ mixer switches and sound volume controls. Clean away dirt. Press the PLAY/PAUSE button (▶/).
Cannot playback MP3s.	<ul style="list-style-type: none"> The files are in the wrong format. 	<ul style="list-style-type: none"> Refer to P.4 "PLAYING MP3 FILES."
Sound is distorted, noise is output.	<ul style="list-style-type: none"> Incorrect connections. Pin plugs and/or amplifier terminals are dirty. Interference is being picked up from a TV set. 	<ul style="list-style-type: none"> Connect to audio mixer's LINE INPUT terminals. (Do not connect to MIC terminals.) Clean away dirt. Switch OFF TV set, move player away from TV set or plug the player into a separate outlet.
With certain discs, loud noise is produced or play stops.	<ul style="list-style-type: none"> Disc has a bad scratch or warp. Disc is extremely dirty. 	<ul style="list-style-type: none"> Replace disc. Clean disc.
When the auto cue function is set ON, track search is not finished.	<ul style="list-style-type: none"> If the sound muted portion between selections is long, searching time will be long. 	<ul style="list-style-type: none"> Press the AUTO CUE button to turn off the Auto Cue function.
Back cue function cannot be carried out even though the CUE button is pressed in playback mode.	<ul style="list-style-type: none"> The cue point is not set yet. The cue point is set to an MP3 file in a different folder. 	<ul style="list-style-type: none"> Set the cue point. (See page 13.) During playback of MP3s, back cue is possible only within the same folder.
Pressing the OUT/OUT ADJUST button does not start loop play.	<ul style="list-style-type: none"> No cue points (loop-in points) have been set. The OUT/OUT ADJUST button was pressed during the playback of an MP3 file other than the one with the cue point (loop-in point) set. 	<ul style="list-style-type: none"> Set a cue point. During playback of MP3s, looping is possible only within the same track that has a cue point (loop-in point) set.
Cannot search MP3s.	<ul style="list-style-type: none"> Attempted to search (fast-forward/fast-reverse) MP3s into a different folder. 	<ul style="list-style-type: none"> Searching with MP3s are only possible within the same folder.
The picture of the TV screen is fluctuated or FM broadcast is interfered with noise.	<ul style="list-style-type: none"> Interference is being picked up from the CD player. 	<ul style="list-style-type: none"> Turn off POWER switch of the player, or move the player away from the TV or tuner.
The disc is not rotating when power is ON.	<ul style="list-style-type: none"> The disc rotation stops automatically if no operation has been performed for 100 minutes or more in pause mode When the last track on the disc is over the disc stops rotating. 	<ul style="list-style-type: none"> Playback can be started from the first track by pressing the PLAY/PAUSE button (▶/). Press the EJECT button (▲) to eject the disc.

- Static electricity and other external effects may cause this unit to malfunction. In this case, set the POWER switch to OFF, then switch it on again after the disc has come to a complete stop.
- This unit cannot playback unfinalized (partial discs) CD-R or CD-RW discs.
- This component is designed to play 12 cm discs and 8 cm discs with a commercially available adaptor, eccentrically shaped discs cannot be played since damage or malfunction may result.
- The BPM value measured by the CDJ-200 may differ from the BPM value recorded on a CD or from our DJ mixer, but this difference is a result of differences in the BPM value measurement method; not a result of a fault with the player.
- When playing CD-R/RW discs, the performance rate may drop due to quality of the recorded data.

Error message display

When the CDJ-200 CD player is unable to operate properly, an error code is displayed on the display panel. Check the error code displayed against the following table and take the recommended action to correct the error. If an error code other than any of the error codes listed in the table below is displayed or if the same error code is displayed even after corrective action has been taken, contact your nearest Pioneer Service Station or contact the store from which you purchased your player for assistance.

Error Code	Error Type	Description	Possible cause and recommended action
E-72 01	TOC READ ERROR	Player unable to read TOC data.	Disc is cracked. → Recommended action: replace disc.
E-83 01 E-83 02 E-83 03	PLAYER ERROR	Disc is rotating, but rotation cannot be ascertained. Player unable to play back currently inserted disc.	Disc is soiled or dirty. → Recommended action: clean disc. If other discs play normally, the problem is with the disc itself.
E-83 04	MP3 DECODE ERROR	The disc loaded cannot be played properly.	The disc format does not conform to MP3. → Change to disc conforming to MP3 format.
E-83 05	DATA FORMAT ERROR		
E-91 01	MECHANICAL TIME OUT	Mechanical operation has failed to complete within specified time interval.	Dust or some other form of foreign particles have found their way into disc insertion slot. → Recommended action: remove dust or other foreign particles.

SPECIFICATIONS

1. General

System.....	Compact disc digital audio system
Power requirements	AC 120 V, 60 Hz
Power consumption	14 W
Operating temperature	+5°C – +35°C (+41°F – +95°F)
Operating humidity	5 % – 85 %
(There should be no condensation of moisture.)	
Weight	3.2 kg (7.1 lb)
Dimensions	216 (W) × 292 (D) × 99.5 (H) mm
	8 – 1/2 (W) × 11 – 1/2 (D) × 3 – 15/16 (H) in

2. Audio section

Frequency response.....	4 Hz – 20 kHz
Signal-to-noise ratio	110 dB or more (JEITA)
Distortion	0.006 % (JEITA)

3. Accessories

● Operating instructions.....	1
● Power cord	1
● Audio cable	1
● Control cable	1
● Forced eject pin (housed in a groove in the bottom panel)	1
● Limited warranty	1

NOTE:

Specifications and design are subject to possible modification without notice.



Dear Customer:

Selecting fine audio equipment such as the unit you've just purchased is only the start of your musical enjoyment. Now it's time to consider how you can maximize the fun and excitement your equipment offers. This manufacturer and the Electronic Industries Association's Consumer Electronics Group want you to get the most out of your equipment by playing it at a safe level. One that lets the sound come through loud and clear without annoying blaring or distortion and, most importantly, without affecting your sensitive hearing.

Sound can be deceiving. Over time your hearing "comfort level" adapts to higher volumes of sound. So what sounds "normal" can actually be loud and harmful to your hearing. Guard against this by setting your equipment at a safe level BEFORE your hearing adapts.

To establish a safe level:

- Start your volume control at a low setting.
- Slowly increase the sound until you can hear it comfortably and clearly, and without distortion.

Once you have established a comfortable sound level:

- Set the dial and leave it there.

Taking a minute to do this now will help to prevent hearing damage or loss in the future. After all, we want you listening for a lifetime.

We Want You Listening For A Lifetime

Used wisely, your new sound equipment will provide a lifetime of fun and enjoyment. Since hearing damage from loud noise is often undetectable until it is too late, this manufacturer and the Electronic Industries Association's Consumer Electronics Group recommend you avoid prolonged exposure to excessive noise. This list of sound levels is included for your protection.

Decibel Level Example

30	Quiet library, soft whispers
40	Living room, refrigerator, bedroom away from traffic
50	Light traffic, normal conversation, quiet office
60	Air conditioner at 20 feet, sewing machine
70	Vacuum cleaner, hair dryer, noisy restaurant
80	Average city traffic, garbage disposals, alarm clock at two feet.

THE FOLLOWING NOISES CAN BE DANGEROUS UNDER CONSTANT EXPOSURE

90	Subway, motorcycle, truck traffic, lawn mower
100	Garbage truck, chain saw, pneumatic drill
120	Rock band concert in front of speakers, thunderclap
140	Gunshot blast, jet plane
180	Rocket launching pad

Information courtesy of the Deafness Research Foundation.



5001_En

Should this product require service in the U.S.A. and you wish to locate the nearest Pioneer Authorized Independent Service Company, or if you wish to purchase replacement parts, operating instructions, service manuals, or accessories, please call the number shown below.

800 - 782 - 7210

Please do not ship your product to Pioneer without first calling the Customer Support Division at the above listed number for assistance.

**PIONEER ELECTRONICS (USA); INC.
CUSTOMER SUPPORT DIVISION
P.O. BOX 1760, LONG BEACH,
CA 90801-1760, U.S.A.**

For warranty information please see the Limited Warranty sheet included with your product.

Should this product require service in Canada, please contact a Pioneer Canadian Authorized Dealer to locate the nearest Pioneer Authorized Service Company in Canada. Alternatively, please contact the Customer Service Department at the following address:

Pioneer Electronics of Canada, Inc.

**300 Allstate Parkway
Markham, ON L3R OP2
(905) 479-4411
1 (877) 283-5901**

For warranty information please see the Limited Warranty sheet included with your product.

Supply of this product only conveys a license for private, non-commercial use and does not convey a license nor imply any right to use this product in any commercial (i.e. revenue-generating) real time broadcasting (terrestrial, satellite, cable and/or any other media), broadcasting/streaming via internet, intranets and/or other networks or in other electronic content distribution systems, such as pay-audio or audio-on-demand applications. An independent license for such use is required. For details, please visit <http://www.mp3licensing.com>.



**Fraunhofer Institut
Integrierte Schaltungen**

MPEG Layer-3 audio coding technology licensed from Fraunhofer IIS and Thomson multimedia.

Published by Pioneer Corporation.
Copyright © 2004 Pioneer Corporation.
All rights reserved.

PIONEER CORPORATION 4-1, Meguro 1-Chome, Meguro-ku, Tokyo 153-8654, Japan

PIONEER ELECTRONICS (USA) INC.

Multimedia and Mass Storage Division: 2265 East 220th Street, Long Beach, CA 90810, U.S.A. TEL: 800-444-OPT1 (6784)

PIONEER ELECTRONICS OF CANADA, INC.

Industrial Products Department: 300 Allstate Parkway, Markham, Ontario L3R OP2, Canada TEL: 905-479-4411