



# PVs 12 Sub Enclosure

---

Operating  
Manual



#### FCC CAUTION:

This device complies with part 15 of the FCC Rules. Operation is subject to the following two conditions: (1) This device may not cause harmful interference, and (2) this device must accept any interference received, including interference that may cause undesired operation.

Any changes or modifications not expressly approved by the party responsible for compliance could void the user's authority to operate the equipment.

NOTE: This equipment has been tested and found to comply with the limits for a Class A digital device, pursuant to part 15 of the FCC Rules. These limits are designed to provide reasonable protection against harmful interference in a residential installation. This equipment generates, uses and can radiate radio frequency energy and, if not installed and used in accordance with the instructions, may cause harmful interference to radio communications. However, there is no guarantee that interference will not occur in a particular installation. If this equipment does cause harmful interference to radio or television reception, which can be determined by turning the equipment off and on, the user is encouraged to try to correct the interference by one or more of the following measures:

- Reorient or relocate the receiving antenna.
- Increase the separation between the equipment and receiver.
- Connect the equipment into an outlet on a circuit different from that to which the receiver is connected.
- Consult the dealer or an experienced radio/TV technician for help.

The equipment complies with FCC radiation exposure limits set forth for an uncontrolled environment,

This transmitter must not be co-located or operating in conjunction with any other antenna or transmitter.

The equipment should be installed and operated with minimum distance 5cm between the radiator and your body.

#### IC WARNING:

This device complies with Industry Canada licence-exempt RSS standard(s). Operation is subject to the following two conditions: (1) this device may not cause interference, and (2) this device must accept any interference, including interference that may cause undesired operation of the device.

Le présent appareil est conforme aux CNR d'Industrie Canada applicables aux appareils radio exempts de licence. L'exploitation est autorisée aux deux conditions suivantes : (1) l'appareil ne doit pas produire de brouillage, et (2) l'utilisateur de l'appareil doit accepter tout brouillage radioélectrique subi, même si le brouillage est susceptible d'en compromettre le fonctionnement.

This Class A digital apparatus complies with Canadian ICES-003.

Cet appareil numérique de la classe A est conforme à la norme NMB-003 du Canada.

the device is compliance with RF exposure guidelines, and the equipment should be installed and operated with minimum distance 5cm between the radiator and your body.

l'appareil est conforme aux directives d'exposition RF, et l'équipement doit être installé et exploité avec une distance minimale de 5 cm entre le radiateur et votre corps.

## ENGLISH

The Peavey® PVs 12 Sub is a compact vented powered subwoofer system utilizing a 12” heavy-duty woofer, coupled to a DSP controlled power amplifier with 1,000 watts peak available power. The full-length black perforated steel grille provides protection and a professional appearance, along with the sturdy steel handles for transport. Two sets of rubber feet allow for the unit to be placed optionally on its side, for low profile situations.

Internal line-level crossover with two high-pass outputs, and one full-range thru output. Peavey’s new switchable bass enhancer for extra bass punch from low frequency program material is incorporated for maximum versatility.

A threaded pole-mount system provides a sturdy and stable platform to mount a suitably equipped speaker system above the sub woofer. There are two of the threaded pole mounts, one on the top, and one on the right side. The top one can be used with smaller powered speakers such as 10” two-ways or the Peavey® P1 BT™, etc., while the right side mount can accommodate larger speakers with the extended base this provides for stability.

The PA™ two-way powered speaker series are an excellent partner for the PVs 12 Sub.

The PVs 12 Sub speaker system power amplifier providing the power is a low-distortion reliable fan-cooled unit providing a total of 1,000W peak available power for the system. The power supply for the power amp is a switch mode type for low weight and high efficiency. The amplifier features DSP processing for the crossover functions, compression and limiting, and the low-frequency EQ.

Input is via a combo female XLR and 1/4” TRS phone jack with balanced input to the preamp/EQ electronics, and a gain control.

A pair of High-Pass Outputs in the form of male XLR jacks provides a buffered and balanced output signal for satellite speakers to carry the high range of the music. A Full-Range Thru output has a male XLR connector. These outputs allow linking of additional speaker systems, or feed of the signal to other devices, etc.

### Features

- Vented bass powered subwoofer enclosure
- 1,000 watts peak available power
- 12” Heavy Duty Woofer
- Power Amp has forced air cooling for maximum reliability
- Internal line level low-pass/high-pass crossover network
- DSP based crossover, compression, limiting and EQ.
- Bass Enhance button for increased bass impact
- XLR/one quarter inch combo jack input
- Two High-Pass XLR outputs, One Full Range Thru XLR output
- Polarity Switch for polarity reversal of subwoofer
- Ground Lift for lifting cable shield from ground
- Full-coverage heavy-duty perforated steel grill
- Steel handles
- Compact dimensions for a 12” woofer based sub
- Threaded Pole Mount with speaker pole included

### Applications

The Peavey PVs 12 Sub has a variety of applications such as extending the bass performance of smaller full-range speaker systems for sound reinforcement, public address, side fill system, karaoke or musical playback.

A typical signal source for the line-level inputs of the Peavey PVs™12 Sub would be a sound reinforcement mixing console (mixer) or the output from a CD player, MP3 player or tape deck. The high-pass filtered signal from the PVs™12 Sub would then be sent to a full-range powered speaker system, easing the burden of deep bass from this speaker system.

## BOTTOM

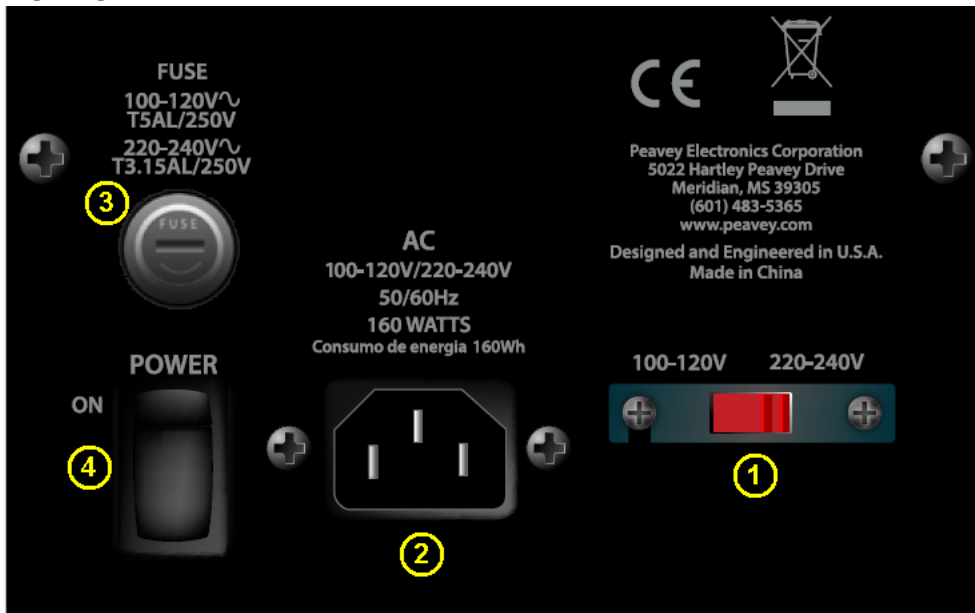

## VOLTAGE SELECTOR SWITCH (1)

The PVs 12 Sub has a voltage selector switch to allow switching between an input power voltage range from 100VAC to 120VAC to a range from 220VAC to 240VAC, all at either 50 or 60 cycles per second (Hz). It should be set to the proper voltage for your country out of the box. However, world conditions are such that some areas have power line voltages differing from the voltage used by the majority of any given locale.

Be sure to check the position of the voltage selector switch to see that it matches the power line voltage used locally. The red slider slot should be toward the voltage required that is printed on the rear panel. If it does not match, then to change the voltage to the correct one, follow the steps outlined below.

## Changing the Voltage Range of the PVs 12 Sub

First, make sure the PVs 12 Sub is disconnected from the power line, and that the power switch (4) is in the OFF position.

Second, unscrew the screws holding the clear switch protector on the voltage selector switch (1) just a little, just enough to allow rotation of the clear switch protector. The screws DO NOT need to be unscrewed very far.

Third, rotate the clear plastic protector about 90 degrees to uncover the voltage selector switch. One side of the cover has a slot; the other just a hole. The side with the hole is the side that pivots.

Fourth, using a small flat blade screwdriver, push the red selector switch slide plate to the other side from where it was. The red slider slot should be toward the desired voltage that is printed on the rear panel.

Fifth, rotate the clear plastic protector back underneath the loosened screws, and tighten one down while holding the clear plastic protector in place. Tighten the other screw down, and make sure both screws are tight. If the screws are over-tightened, this could damage the voltage selector switch clear plastic cover, so do not apply excessive force to the screws!

Sixth, the fuse should be changed to the correct amperage rating. For an input power voltage range from 100VAC to 120VAC, use a 5 amp rated, 250V 5 x 20 mm cartridge type time-delay fuse, which conforms to the international fuse classification “T5AL”. For an input power voltage range of from 220VAC to 240VAC, use a 3.15 amp rated, 250V 5 x 20 mm cartridge type time-delay fuse, which conforms to the international fuse classification “T3.15AL”.

See Fuse section for detailed instructions on how to remove and install the fuse.

The IEC power cord that is correct for your locale can now be plugged into the IEC receptacle (2), and the Power switch (4) activated to turn on the poweredPVs12 Sub speaker system.



#### IEC POWER CORD CONNECTION (2)

This receptacle is for the IEC line cord (normally supplied with the correct pins and wiring for your locale) that provides AC power to the unit. It is very important that you ensure the PVs 12 Sub has the proper AC line voltage supplied. You can find the voltage setting for yourPVs12 Sub by checking the voltage selector switch on the rear panel of the unit. See above section.



Please read this guide carefully to ensure your personal safety as well as the safety of your equipment. Never break off the ground pin on any equipment. It is provided for your safety. If the outlet used does not have a ground pin, a suitable grounding adapter should be used and the third wire should be grounded properly. To prevent the risk of shock or fire hazard, always be sure that the mixer and all other associated equipment are properly grounded.



#### FUSE (3)

The unit is AC power line fuse protected from overloads and fault conditions with a slow-blow 5 x 20mm 250V fuse. This fuse is located within the cap of the fuse enclosure just above the ON-OFF switch. If the fuse fails, **THE FUSE MUST BE REPLACED WITH THE SAME TYPE AND VALUE IN ORDER TO AVOID DAMAGE TO THE EQUIPMENT AND TO PREVENT VOIDING THE WARRANTY!**

The fuse in the PVs 12 Sub can be replaced with a time-delay type 5 x 20 mm size 250V rated fuse.

For 100-120VAC operation, a fuse rated at 5 amps should be used. In the USA, types GDC, GMC, 215, 218, and 477 cartridge-style 5 x 20 mm size fuses with a 5 amp 250V rating can be used. The fuse should conform to the international fuse classification “T5AL”.

For 220-240VAC operation, a fuse rated at 3.15 amps and 250V should be used, which conforms to the international fuse classification “T3.15AL”.

If the unit continues to blow replacement fuses, do not keep replacing them- it should be taken to a qualified service center for repair.

To replace the fuse, be sure to remove the IEC power cord from the IEC socket (2).

Remove the cap to the fuse enclosure (3) using a flat blade screwdriver tip inserted into the fuse cap slot. Push the cap in and turn the cap CCW and pull the cap out. The blown fuse should come out with the cap. Remove the blown fuse and replace it with the proper type per instructions previously supplied. Then, once the new fuse has been put in place, re-insert the fuse enclosure cap, push in and turn the cap CW, and make sure it is fully seated.

Before re-attaching the IEC power cord to the IEC socket, make sure the Power switch is in the OFF position, so that intermittent contact of the IEC cord while it is being connected will not unduly stress the amplifier or the fuse.

Now re-attach the IEC power cord, and you can then use the Power switch to turn the unit on.

#### ON-OFF SWITCH (4)

This rocker switch supplies AC power to the PVs 12 Sub when switched to the ON position. The ON position is with the upper portion of the switch pushed “in” or nearly flush with the rear panel.

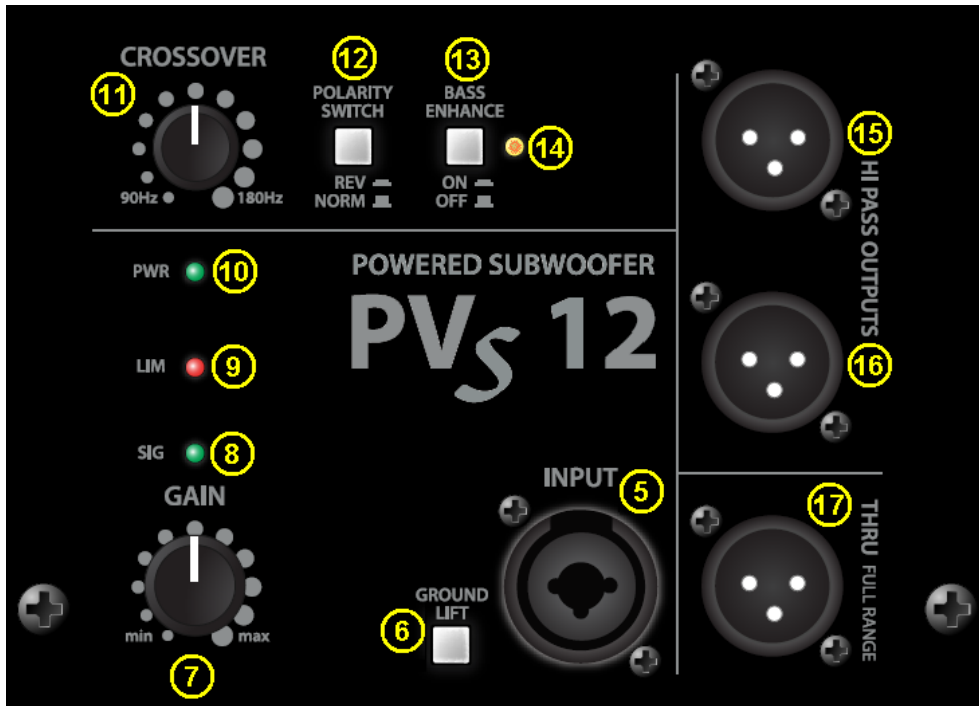

#### INPUT (5)

The line-level input is of the medium impedance balanced type. The jack is a combo female XLR and 1/4" TRS connector.

#### GROUND LIFT Switch (6)

Provided for lifting cable shield from chassis ground, to break potential ground loops and reduce hum.

#### GAIN (7)

Controls the gain or output level of the input signal. It is used to directly set the system output level for a given input signal.

Normal usage is with the knob set to half-way, this is then equivalent in gain to a typical power amp input.

#### SIG LED (8)

Illuminates GREEN when a signal is present at the input jack (5).

#### LIM LED (9)

It illuminates RED when the power amp engages the compression or limiting circuitry. Regular flashing is acceptable, but not a constant illumination, or distortion will be excessive.

#### PWR LED (10)

Illuminates GREEN when the power switch is on and power is present.

### CROSSOVER Frequency Control (11)

Varies the crossover frequency between the Subwoofer and the High Pass Outputs sent to the satellite/s speaker/s (14 & 15). Varies the electrical crossover frequency from 90 Hz to 180 Hz.

**CAUTION! SETTING THIS CONTROL TOO LOW MAY ALLOW THE SATELLITE SPEAKER TO BE OVERLOADED BY DEEP BASS!**

Setting the control lower DOES NOT increase the deep bass output of the PVs 12 Sub, a middle range (9:30 to 2:30 clock face position) setting works best for most speakers.

### POLARITY SWITCH (12)

Provides either Normal (0 degrees) or Reverse (180 degrees) sub woofer polarity. This switch is used in conjunction with the Crossover Frequency Control (11) to provide for the best match between the Subwoofer output and the satellite speaker output in the crossover region.

### BASS ENHANCE SWITCH (13)

Provides the capability to add extra punch to the bass to enhance the perception of deep bass in the program material without overloading the Subwoofer speaker. Useful for DJ and EDM music genre's, it may cause excessive boom if used for vocals or acoustic instruments.

### BASS ENHANCE LED (14)

Illuminates Orange when the Bass Enhance switch has been engaged.

### HIGH PASS OUTPUTS (15 & 16)

These outputs provide a high-pass filtered signal to be fed to a full-range powered speaker system. Other full-range powered speakers can be used, and full-range passive speakers can be used in conjunction with a suitable power amp to drive them.

These outputs are electronically buffered and isolated from the input, and their level is controlled by the PVs 12 Sub GAIN control (7). Thus, once the gain relationship between the Sub and the satellite speaker system has been established, the overall gain of the combined Sub and satellite system can be changed with the PVs 12 Sub GAIN control (7).

### THRU FULL RANGE OUTPUT (17)

This output provides a full-range signal to be sent to any other device that requires a full-range signal, such as another PVs 12 Sub, or some other line level audio device. This output is paralleled with the input, and the gain does not change with changes in the PVs 12 Sub GAIN control (7).

## Cautions

---

The unit must be disconnected from the AC power source before any work is done on it. Refer all servicing to qualified service personnel.

The back plate can become hot to the touch. Do not block or cover the fan or the exhaust louvers from ventilation. There must be a minimum of 12" of space behind the fan. Do not allow the airflow to become blocked by objects such as curtains or drapes, thermal building insulation, etc. It is recommended that the rear of the PVs 12 Sub not be placed in a closed space or a space that has no fresh, cool airflow.

DO NOT connect the inputs of the PVs 12 Sub to the output of a power amplifier. The inputs are meant to be driven from a line-level strength signal.

DO NOT remove the protective metal grilles.

**WARNING!** The PVs 12 Sub is very efficient and powerful! This sound system can permanently damage hearing! Use extreme care setting the overall maximum loudness!

The apparent sound level of the PVs 12 Sub can be deceiving due to its clear, clean sound output and lack of high frequencies. The lack of distortion or obvious distress can make the sound level seem much lower than it actually is. This system is capable of SPL in excess of 125 dB at 1 M from the speaker!

### **Placing A Satellite Speaker System On Top Of The PVs 12 Sub**

The PVs 12 Sub has a threaded pole mount built-in to the top of the unit, and this is designed to mate with an M20 threaded pole of adjustable length. This pole is designed to be used with speaker systems less than 29" high and less than 44 lbs. in weight. Do not place a taller/larger or heavier speaker system than this on the top pole mount and pole, or it may be unsafe due to the potential to tip over.

The adjustable pole should only be used with the PVs 12 Sub in the upright orientation with an adjusted length of 36.88" (93.6 cm), which is the first pin position exposed when the center pole is pulled out from the base pole section.

**DO NOT USE A LONGER POLE LENGTH IN THIS ORIENTATION, AS IT MAY BE UNSAFE AND ALLOW THE SUB AND SATELLITE SPEAKER TO TIP OVER!**

There is also a threaded pole mount built-in to the right side of the unit. This can be used when the PVs 12 Sub is placed on its left side, and the adjustable pole set to no longer than 44.75" (113.7 cm), which is the third pin position as you pull the center pole out from the base pole section. This is the middle hole of the 5 sets of holes in the center pole.

**DO NOT USE A LONGER POLE LENGTH IN THIS ORIENTATION, AS IT MAY BE UNSAFE AND ALLOW THE SUB AND SATELLITE SPEAKER TO TIP OVER!**

### **Setting the Adjustable Pole Length**

The adjustable pole will ship in the shortest position possible for packing reasons. To use the pole safely, follow the instructions for setting its length as follows.

1. Keeping the pole upright, loosen the position hold knob till the center pole can move freely, but not too much, as the lock knob friction plate may fall out with too much space between the knob bolt threads and the center pole. Keep the pole upright while this procedure is being performed.
2. Pull the center pole out from the base pole section until the desired set of holes is exposed. **DO NOT PULL**



THE CENTER POLE ALL THE WAY OUT, AS THE LOCK KNOB FRICTION PLATE MAY COME LOOSE AND NEED TO BE RE-INSTALLED IN PLACE. There are five sets of position holes, so once the fifth set is exposed, do not pull the center pole out any further.

With this model XS-Sub, the bottom most two sets of position holes will not be used due to safety considerations.

3. Once the desired set of position holes is selected, insert the pin into both holes, and let the center pole slide down till the pin is butted up against the base pole.

4. Tighten the position hold knob till it is firmly holding the center pole. Do not over tighten, or use pliers or other mechanical aids to tighten the knob, as this may damage it or damage the lock knob friction plate.

5. Now the adjustable pole can be inserted and threaded into place on the PVs 12 Sub. Tighten firmly by hand using the base portion of the pole, do not over tighten, or use pliers or other mechanical aids to tighten the pole into the Sub mounting plate.

The PVs 12 Sub must be placed on firm and level ground, in order for the pole mounted speaker to be safe from tipping. When installing or de-installing the speaker on the pole, it is a good practice to have a helper if possible, it can be hard to “thread the needle” and mate the pole cup to the Subwoofer pole while holding the speaker system at arm’s length.

When using the PVs 12 Sub and pole outdoors, never attach banners or flags to the pole or the pole mounted speaker system, strong winds may cause the speaker to blow over. If there is a possibility of strong windy conditions, then it may be prudent to consider removing the speaker from the pole to prevent the PVs 12 Sub and pole mounted speaker system from being blown over.

## **Connecting AC Power To The PVs12 Sub**

The PVs 12 Sub typically comes with a 7.5-foot (or longer) IEC connection AC power cord. If you are using an extension cord or power strip with this powered speaker, make sure it is of good quality and of a sufficient current capacity to maintain safety and maximize the power output capability of the PVs 12 Sub. For maximum undistorted output, do not connect any other device to the same extension cord that the PVs 12 Sub is connected to. Do not exceed the rated current capacity of the extension cord with the sum total of all units connected to it. When first plugging in the PVs 12 Sub AC cord, make sure the power switch is in the Off position, and then turn it On only once the power cord has been connected. Built-in muting will engage when the proper sequence of steps is taken.

## **Special Note for Permanent Installation**

When installing the PVs 12 Sub, AC power runs will be used and a certified electrician should be consulted to be sure that all AC wiring complies with local codes and regulations. It is also advisable to use a cable clip properly affixed to the cabinet to strain relief the IEC power cord connected to the amplifier module at (2) so the power cord cannot be pulled out or vibrate loose.

## **Connecting a Signal to the PVs12 Sub**

There are a variety of ways to input a signal to the PVs 12 Sub.

The input (5) provides a balanced line-level input, allowing the use of a 1/4" TRS (ring-tip-sleeve) type phone plug or a male XLR plug. Of course, an unbalanced 1 / 4 " phone plug can be used as well, but it will not have the benefit of the balanced connections rejection of outside interference such as hum and RFI.

Do not connect cables to the jacks while the unit is ON and the Gain knob is turned up! While a standard single-ended 1/4" phone plug-equipped cable will work well and the balanced input circuitry will provide some interference rejection, a balanced cable using either the balanced TRS 1/4" phone plug or the XLR plug will provide superior interference rejection and performance.

Sometimes, with difficult interference problems, it will be helpful to lift the shield ground ( Pin #1 of an XLR) of a balanced cable at the PVs 12 Sub end. This can be done quite easily by activating the Ground Lift switch (10) built-in to the PVs 12 Sub. Check any input changes carefully, always turning the Gain control down before plugging and unplugging cables, or lifting the ground.

Use of high quality, premium cables is recommended for the PVs 12 Sub, as these usually have better shielding and materials and will provide greater long-term reliability. The best option is a shielded balanced cable no longer than necessary to reach the PVs 12 Sub. It is usually a good idea to leave some slack at the input to the PVs 12 Sub and also to tape the cables down or run them under a cable guard to avoid anyone tripping over them or pulling the PVs 12 Sub over when it is holding a speaker on top of it's pole.

## **Gain Control Adjustment**

The PVs12 Sub is equipped with a Gain control (7) on the input to facilitate use in many different applications. With the Gain control adjusted fully clockwise, gain is at maximum and the input sensitivity is 0.16 V RMS for full-rated output.

It is recommended that the PVs 12 Sub Level control be set close to straight up. At this setting, the input sensitivity is approximately 1.4 volts RMS for full-rated output. The PVs 12 Sub will now more closely match a typical power amp input.

If the mixing board indicates clipping of its output signals, then all of the PVs 12 Sub power capability is not being utilized cleanly. Clipping the signal before it gets to the PVs 12 Sub is not optimal. Reduce the mixer output level and turn up the Gain control on the PVs 12 Sub.

The amplifier in the PVs 12 Sub is equipped with DSP based compression and limiting and the LIM LED indica-

tor will show when this system has engaged. If the sound seems heavily compressed, check this indicator; if it is mostly illuminated RED, then the drive level from the mixer (or the Gain control on the PVs 12 Sub) needs to be reduced. It is OK for the LIM LED to blink RED regularly, as this means the system is doing its job to allow you maximum output before the signal becomes audibly distorted.

When first turning on the sound system, switch on all upstream electronics first, then the PVs 12 Sub with its Gain control fully counterclockwise (all the way down). Begin checking levels with the mixer output level controls all the way down, and bring them up slowly with the PVs 12 Sub Gain control set to the desired setting (one-half way up recommended to start).

It is not good practice to turn the Gain control on the PVs 12 Sub all the way up and then try to control level only from the mixer, this approach would tend to pick up excess noise. Best practice would be to run a “hot” signal from the mixer down the cable to the PVs 12 Sub, and then turn the PVs 12 Sub Gain control up only as much as necessary to reach full desired output. With this approach, it is necessary to verify the mixer output is not clipping.

### **Cables from the High Pass Outputs (15 & 16)**

The preferred method of connecting a full-range satellite speaker system to the PVs 12 Sub's High Pass Outputs (15 & 16), is to use a balanced XLR cable no longer than necessary to comfortably reach the satellite speaker system.

If the satellite speaker is on top of a pole above the PVs 12 Sub, then a 6 foot cable will be plenty long. A 10, or 20 foot cable could also be used, but cables longer than that will only allow more interference pickup, and possibly start to lose high frequency information. Use of high quality, premium cables is recommended for the PVs 12 Sub, as these usually have better shielding and materials and will provide greater long-term reliability. It is usually a good idea to leave some slack at the output of the PVs 12 Sub, and also to tape the cables down or run them under a cable guard to avoid anyone tripping over them or pulling the PVs 12 Sub over when it is holding a speaker on top of its pole.

### **Recommended Settings for Use of the PVs 12 Sub with other Peavey Powered Speakers**

The ideal location for placement of the Peavey powered series full-range speakers is on top of the PVs 12 Sub pole. In that close proximity, the following settings will provide the best results in the crossover region, and for tonal balance.

## Frequency & Polarity

### SUB MODEL>

### PVs 12

Top Box Model

#### PA12

Xover Frequency  
Polarity  
Top Box Level/Gain

160 Hz/135 Hz  
Normal/Normal  
1:30 o'clock

Frequencies corresponding to the  
Crossover knob position:  
Full CCW (7 o'clock) equals 90 Hz

#### PA15

Xover Frequency  
Polarity  
Top Box Level/Gain

135 Hz/110 Hz  
Normal/Reverse  
1:30 o'clock

Half-way between full CCW and  
straight up (9:30 o'clock) equals 110  
Hz

Straight Up (12 o'clock) equals 135 Hz

#### DM112

Xover Frequency  
Polarity  
Top Box Level/Gain

135 Hz/110 Hz  
Normal/Reverse  
12 o'clock

Half-way between straight up and full  
CW (2:30 o'clock) equals 160 Hz

Full CW (5 o'clock) equals 180 Hz

#### DM115

Xover Frequency  
Polarity  
Top Box Level/Gain

135 Hz/110 Hz  
Normal/Normal  
12 o'clock

#### PVXp10 DSP

Xover Frequency  
Polarity  
Top Box Level/Gain

160 Hz/135 Hz  
Normal/Reverse  
9:30 o'clock

#### PVXp12 DSP

Xover Frequency  
Polarity  
Top Box Level/Gain

160 Hz/135 Hz  
Normal/Normal  
9 o'clock

#### PVXp15 DSP

Xover Frequency  
Polarity  
Top Box Level/Gain

135 Hz/110 Hz  
Normal/Reverse  
9 o'clock

#### P1 BT

Xover Frequency  
Polarity  
Top Box Level/Gain

160 Hz/135 Hz  
Normal/Normal  
Channel full CW  
Master 3 o'clock

#### P2 BT

Xover Frequency  
Polarity  
Top Box Level/Gain

160 Hz/135 Hz  
Normal/Normal  
Channel full CW  
Master 12 o'clock

**CAUTION! SETTING THE CROSSOVER FREQUENCY CONTROL TOO LOW MAY ALLOW THE SATELLITE SPEAKER TO BE OVERLOADED BY DEEP BASS AT HIGH SPL !**

Setting the control lower DOES NOT increase the deep bass output of the PVs 12 Sub, a middle range (9:30 to 2:30 clock face position) setting works best for most speakers.

If the powered full-range speakers are not set on top of the PVs12 Sub on the pole, then the polarity switch settings may need to be different than what is provided here. The Crossover Frequency Control may need to be set to a slightly lower point in order for the Subwoofer and the satellites to sum well through the crossover region. The settings outlined above will work the best when the satellite speaker and the Subwoofer are closer together, and essentially the same distance from the audience.

**Setting the PVs12 Sub Controls for Use with Other Satellite Speakers**

Crossover Frequency Control (11): In general, for smaller full-range speakers to be used as satellites, set the Crossover Frequency Control (11) to a higher frequency setting. For larger full-range speakers, set the Crossover Frequency Control (11) to a lower frequency setting. Setting the Crossover Frequency Control very much below the 10 o'clock position for smaller satellite speakers will not be needed most of the time, as a crossover frequency below 110 Hz is not going to allow the PVs15 Sub and the smaller satellite speaker to add together very well in the crossover region.

Polarity Switch (12): Try changing the Polarity Switch setting back and forth at each selected crossover frequency, so as to determine which switch position provides the most bass output in the crossover region. When listening, either have someone else toggle the Polarity switch, and listen back where the audience will be, or toggle the polarity and then go listen in the audience area. Listening while standing behind the Sub will not allow you to hear the correct summation of the Sub and the top speaker.

Level Controls (7): Start with the PVs 12 Sub Level control in the straight up position, and adjust the satellite speaker system to match it's level. Note that if the Subwoofer can be heard as a distinctly separate sound source, then it is probably set too high in level.

**Disconnecting AC Power to the PVs 12 Sub**

We recommend that the Power switch (4) be used to turn the unit off first, and then the AC power cord can be removed, this minimizes stress to the power amplifiers and the transducers from turn-off transients. The power switch has an arc suppression capacitor to help during turn-off, and tends to make a clean disconnect from the AC power, while the power cord IEC connector can make intermittent contact before finally becoming fully disconnected, e.g., as when wiggling the cord.

### **No Output at All**

First, make sure the unit has AC power and is turned ON. Make sure the LED on the power amp module is illuminated.

If not, make certain the ON/OFF switch (4) is in the ON position and check the IEC power cord connection (2) by ensuring it is fully engaged and seated. Make certain the AC line cord is plugged into a working AC outlet. Finally, check the fuse (3). (See the Rear Panel: Fuse section, for safety instructions.)

Once assured your unit is getting AC power, check that the PVs 12 Sub is getting a signal. Temporarily disconnect the cable running to its inputs and connect it to some other device capable of reproducing the signal (i.e., a power amp and speaker). If this produces a signal, make sure that all Gain/Level controls being used have been turned up to a satisfactory level (one-third to halfway).

If the PVs 12 Sub has been subjected to direct sunlight or excessive heat, the built-in thermal protection may have been triggered. If so, turn off the PVs 12 Sub and let it cool for a sufficient amount of time.

If there is still no output, contact your authorized Peavey dealer or the Peavey International Service Center.

### **Hum or Buzz**

If the PVs 12 Sub is producing a hum or buzz, this can be AC outlet related. Try plugging the PVs 12 Sub into a different AC outlet. Sometimes, if a different circuit (breaker) is used for the mixer and for the PVs 12 Sub, it can cause hum problems. Unless it is not practical, it is best to use the same wall outlet (breaker) to supply power to both the mixer and the powered speaker.

Ensure that shielded cables have been used to route the signal to the PVs 12 Sub's input. If speaker cables with 1/4" plugs are used as input cables instead of shielded cables, they will be prone to hum or buzz.

Hum may be ground loop related. It may be helpful to lift the shield ground (Pin #1) on a balanced cable at the PVs 12 Sub end. This is done quite easily by activating the Ground Lift switch (6) built-in to the PVs 12 Sub. Check any input changes carefully by first turning down the Gain control, before plugging and unplugging cables, or lifting the shield ground at the Sub.

Check to make sure light dimmers are not on the same circuit as the PVs 12 Sub, the mixer or any source devices. If light dimmers are used, then it may be necessary to turn them full ON or full OFF to eliminate or reduce hum. This is a typical AC wiring/light dimmer interference problem, not a design flaw of the PVs 12 Sub.

The third wire (ground plug) on the AC plug should NEVER be removed or broken off, as this is a potential safety hazard.

### **Distorted or Fuzzy Sound**

First, ensure the mixer (signal source) is not clipping or being overdriven. Make sure the Gain (7) control on the PVs 12 Sub has not been set too low. Check that the input plug is fully seated in the input jack on the rear panel of the PVs 12 Sub. Ensure that a power amp has not been plugged into the input jack of the PVs 12 Sub. If an extension cord is being used to provide the AC power to the unit, insure that it is of sufficient current capacity and that it is not also being used to supply power to any other device.

The PVs 12 Sub has a built-in bass boost to extend and smooth the natural response of the speakers in the sys-

tem, so it should require little, if any, additional EQ.

A Bass Enhance button has been provided to increase the punch of the PVs 12 Sub, and this should definitely not have any additional bass boost used with it, it WILL cause premature compression and limiting, and greatly reduce the dynamics of the bass.

Reduce the amount of any external (mixer, rack) EQ and see if that clears up the distortion.

Finally, realize that even though the PVs 12 Sub is a powerful and high output unit, it does ultimately have limits, and it may need additional powered Subwoofer units to provide enough sound output or coverage. In this case, try turning the mixer levels down a little to see if that clears things up. If, after checking all the things listed to check and anything else you can think of to check safely, and the system still exhibits problems, carefully note all conditions and check with your Peavey dealer for advice.

### **Care and Maintenance**

Your PVs 12 Sub is a sturdy and durable product and will provide years of reliable use if properly cared for. Use common sense and read the safety warnings to avoid hazardous operating conditions.

The unit must be disconnected from the AC power source before any work is done on it. Refer all servicing to qualified service personnel.

### **Sunlight/Heat**

Avoid prolonged exposure to direct sunlight, as this may cause the unit to overheat and thermally shut off.

Excessively hot operating conditions can also cause a thermal shutdown.

Do not store in extremely hot or cold conditions or extremely high humidity. Always allow unit to come to room temperature before use.

### **Cleaning**

Never clean the PVs 12 Sub while plugged in or turned ON! When the unit has been fully disconnected from AC power sources, use a dry cloth to remove soil or other dirt. Never use strong solvents on the PVs 12 Sub, as they could damage the cabinet. Do not allow ANY fluids to drip inside the PVs 12 Sub.

### **Touchup**

For a touch-up of any damage to the black painted finish of the PVs 12 Sub, you can use a black spray paint such as Peavey Commercial Sound, Black Touch-Up Paint, Peavey part number 00052110. Follow the directions on the can for safety and best results.

### **Check for Secure Hardware**

After the first few months of use and periodically thereafter, check the hardware of the PVs 12 Sub for tightness, including the rear panel screws and the screws that hold the grille and cabinet together.

The unit is subject to a great deal of vibration, and this could cause them to loosen with use.

The powered loudspeaker system shall have a frequency response from 53 Hz to 180 Hz with the Crossover knob turned all the way CW, and from 53 Hz to 90 Hz with the Crossover knob turned all the way CCW, at the - 6 dB points. The peak SPL with inaudible distortion shall reach 125 dB with music as a source, when measured at a distance of 1M and driven to full output capacity. The system shall utilize a premium 12" heavy-duty woofer in a vented enclosure tuned to 50 Hz.

The powered loudspeaker system shall have an input channel consisting of a medium impedance balanced input connector consisting of one combo female XLR and 1/4" TRS phone jack on the rear panel. A Ground Lift Switch shall be provided to allow the disconnection of the input cable shield from the system ground to provide for breaking any possible ground loops.

There shall be a Direct Thru (output) connector consisting of a male XLR jack.

There shall be two female XLR jack filtered high-pass outputs providing a crossed over signal to satellite speakers.

The system power amplifier shall have an unfiltered frequency response of 20 Hz to 20 kHz which deviates no more than +1, -3 dB up to rated power, hum and noise better than 90 dB below rated power, and THD typically of less than 0.1%.

The power amplifier shall be capable of 500W sine wave output into a 4 ohm nominal load, and 1000W peak available power, and shall incorporate DSP controlled signal compression and limiting.

The input signal shall be electronically divided into high frequencies and low frequencies by a Linkwitz-Riley fourth order slope line-level crossover, with crossover frequencies variable from 90 Hz to 180 Hz via a rear panel Crossover knob. The low frequencies shall be processed to provide bass boost, subsonic filtering and overall response shaping, and the high frequencies shall be made available flat. A Bass Enhance button shall be provided to enable additional bass frequency output at lower SPL levels. A Polarity Switch shall be provided to allow the subwoofer polarity to be switched from Normal to Reversed polarity.

The enclosure shall be constructed of 15 mm MDF with a textured black finish. A pair of steel handles shall be incorporated on the sides of the cabinet and four sturdy rubber feet on the bottom and four on the left side for floor standing use.

A full-length powder-coated metal grille shall be provided for woofer protection. The cabinet shall incorporate a threaded pole mount for a pole to be used for a satellite speaker, one on top, and one on the right side. The threaded pole shall be included.

The outside dimensions shall be: 21.75" (54.8 cm) tall x 14.38" (36.5 cm) wide x 20.13" (51.1 cm) deep, and the weight shall be 57 lbs. Power requirements shall be: 160 Watts nominal, 120 VAC, 50/60 Hz Domestic and 220-240 VAC, 50/60 Hz (Export). The loudspeaker system shall be called a Peavey®PVs12 Sub.



# Typical Hook-up Connections

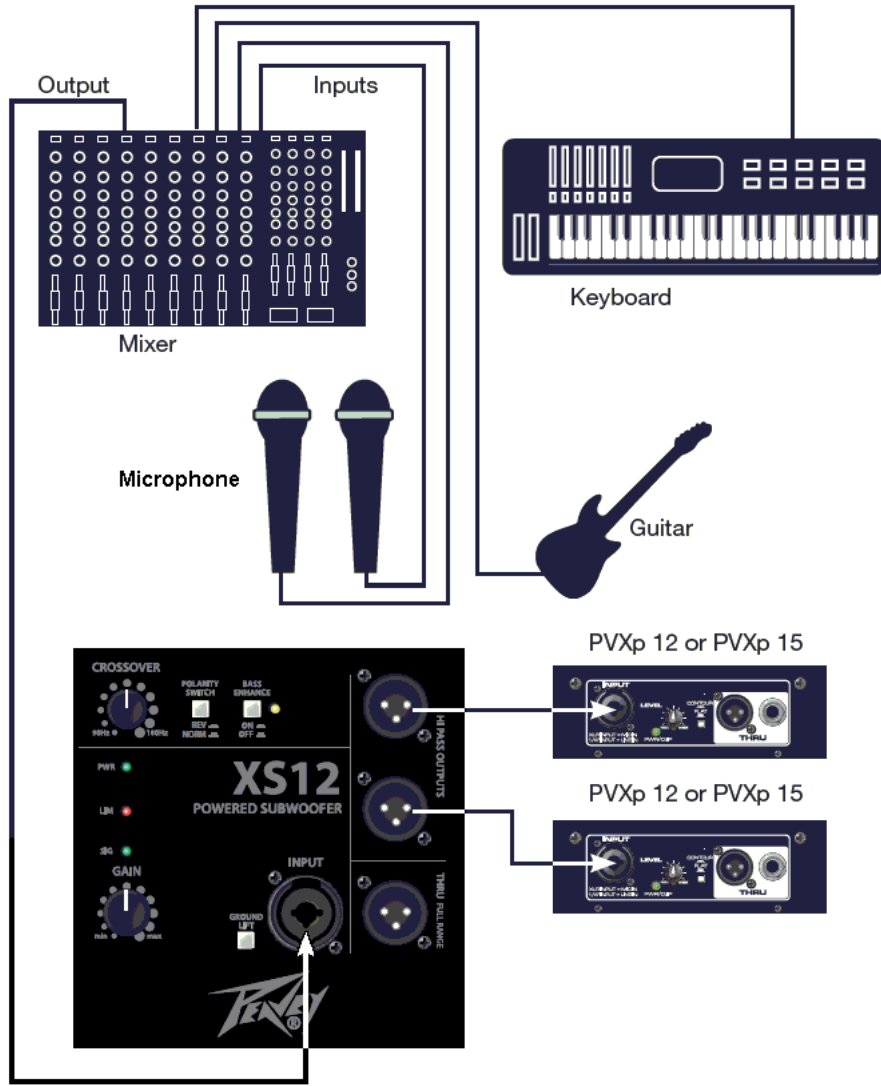

## Daisy-Chain Connection (Multiple Subs)

Input to  
1st Sub

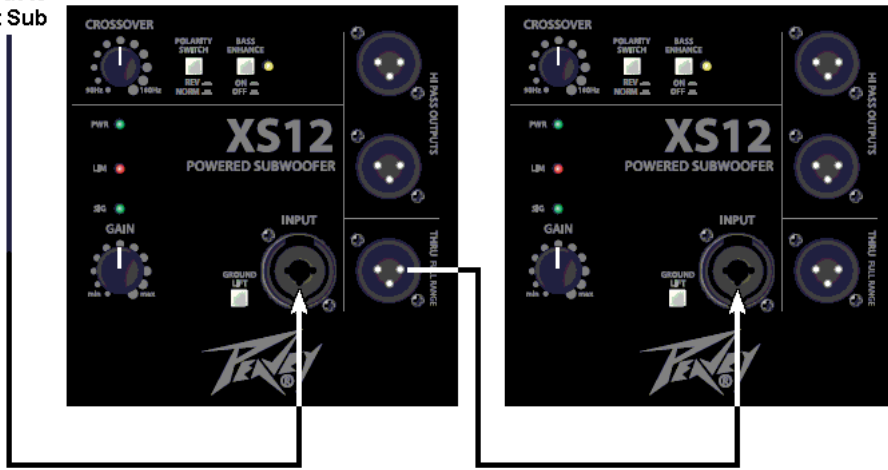

Input to 2nd Sub

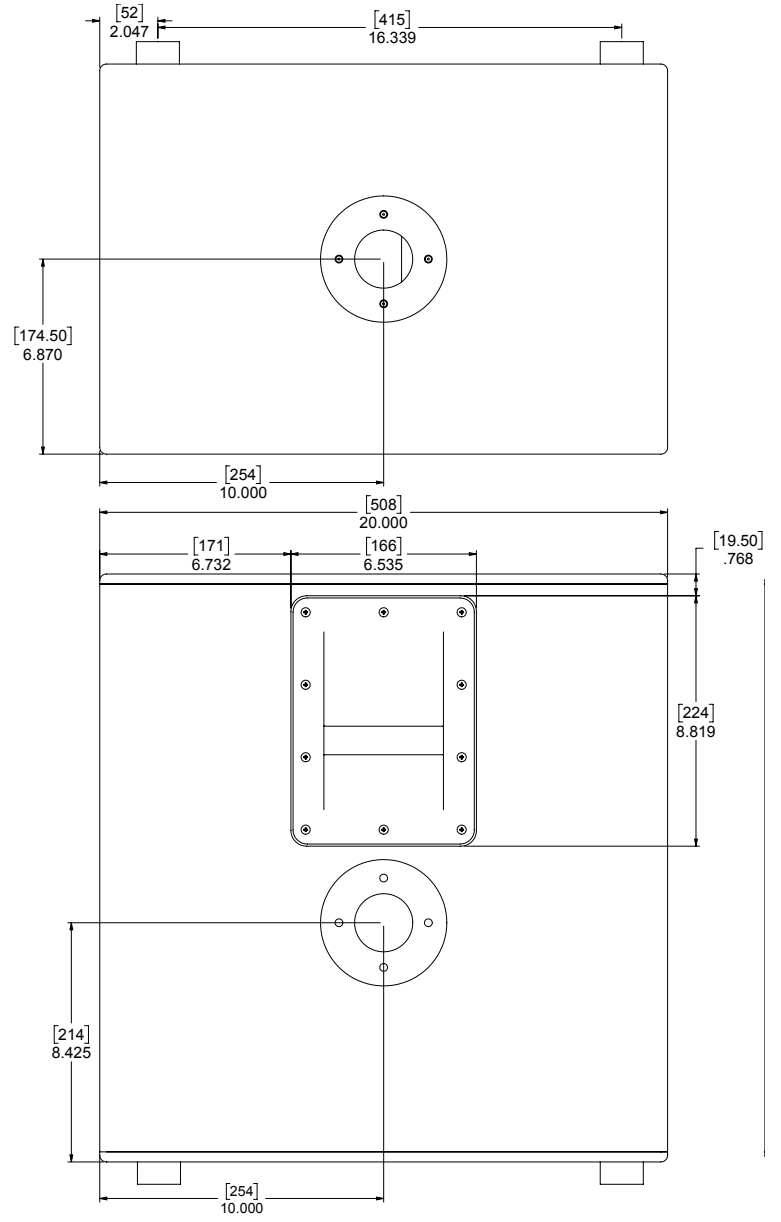
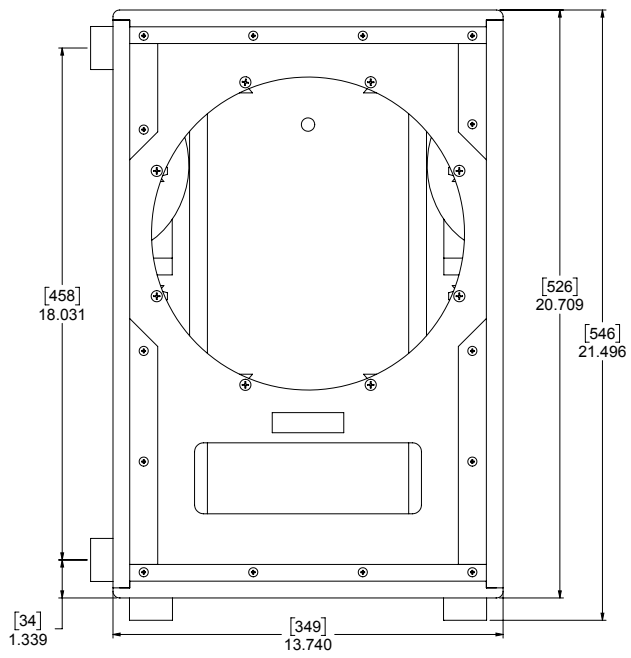

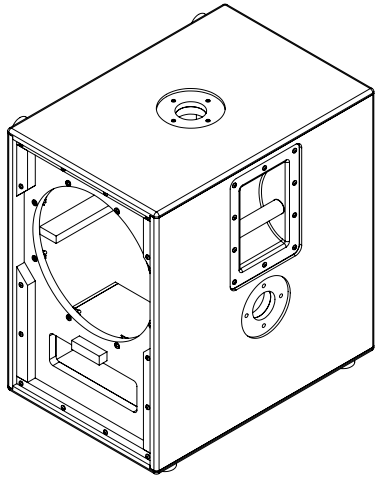

1

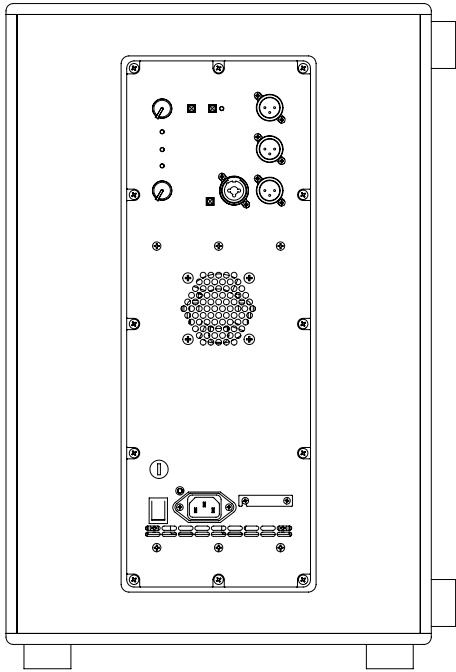

## Specifications

---

### **Frequency Response, 1 meter on-axis, swept-sine in half space**

#### **Environment (-6 dB):**

53 Hz – 180 Hz (Crossover Control Full CW)

53 Hz – 90 Hz (Crossover Control full CCW)

#### **Low Frequency range (-10 dB, half space):**

48 Hz

#### **Power Amp Rating:**

1,000 watts peak available power

**Sine wave Power:** 500 watts into 4 ohms (Output duration is limiter controlled)

#### **Electronic Input Impedance (Nominal):**

Line In: 20 k ohms balanced (XLR or 1/4"), 10 k ohms unbalanced 1/4"

#### **Maximum Sound Pressure Level (1 meter in half space):**

122 dB SPL continuous

125 dB SPL peak

#### **Transducer Complement:**

12" premium heavy-duty woofer, 2.5" voice coil, 50 oz. magnet.

#### **Box Tuning Frequency:**

50 Hz

#### **Input Connections:**

One combo female XLR/ 1/4" phone jack providing balanced or unbalanced operation.

#### **Electronic Input Impedance (Nominal):**

Line In: 20 k ohms balanced (XLR or 1/4"), 10 k ohms unbalanced 1/4"

#### **Output Connections:**

Two High Pass Outputs.

One Full Range Thru.

#### **Controls:**

Level: Provides Off to + 20 dB gain adjustment

#### **Crossover Frequency Adjust:**

Adjusts electrical crossover frequency from 90 Hz to 180 Hz, in 15 discrete steps.

#### **Bass Enhance:**

Provides bass enhancement processing.

#### **Polarity Switch:**

Provides either Normal (0 degrees) or Reversed (180 degrees) sub woofer polarity.

Ground Lift Switch for input.

**Electronic Crossover**

Linkwitz-Riley crossover variable from 90 Hz to 180 Hz.

**Low Pass slope:**

24 dB/octave

**High Pass Output slope:**

24 dB/octave

**Infrasonic Filter Slope:**

36 dB/octave

**Nominal Amplifier Frequency Response:**

+0, -3 dB from 20 Hz to 20 kHz

**Hum and Noise:**

Greater than 90 dB below rated power

**THD and IM:**

Typically less than 0.1 %

**Power requirements of PeaveyPVs12 Sub System:**

Nominal 160 Watts, 100-120 VAC 50-60 Hz (Domestic)

220-240 VAC 50-60 Hz (Export)

**Enclosure Materials & Finish:**

Black acrylic painted enclosure with 15 mm MDF, with a full-length, black powder coated perforated steel grille. Eight rubber feet for floor use on the bottom and for on the left side.

**Dimensions (H x W x D)**

21.82 in. x 14.38 in. x 20.13 in.

554 mm x 365 mm x 511 mm

**Net Weight:**

57 Lbs. (25.9 kg)

**Mounting Provisions:**

Two 1 3/8" pole mounts with M20 threaded pole for stand mounting a suitable speaker on top of the Sub, and four large rubber feet on bottom and on the side for floor use. Threaded pole is supplied with the unit.









[www.peavey.com](http://www.peavey.com)

Warranty registration and information for U.S. customers available online at  
[www.peavey.com/warranty](http://www.peavey.com/warranty)  
or use the QR tag below



Features and specifications subject to change without notice.

Peavey Electronics Corporation 5022 Hartley Peavey Drive Meridian, MS 39305 (601) 483-5365 FAX (601) 486-1278



Logo referenced in Directive 2002/96/EC Annex IV  
(OJ(L)37/38,13.02.03 and defined in EN 50419: 2005  
The bar is the symbol for marking of new waste and  
is applied only to equipment manufactured after  
13 August 2005